



PureConnect®

2023 R3

Generated:

09-November-2023

Content last updated:

05-August-2020

See **Change Log** for summary of changes.



Interaction Attendant

Printed Help

Abstract

This document contains the application help for Interaction Attendant.

For the latest version of this document, see the PureConnect Documentation Library at: <http://help.genesys.com/pureconnect>.

For copyright and trademark information, see https://help.genesys.com/pureconnect/desktop/copyright_and_trademark_information.htm.

Table of Contents

Table of Contents	2
Interaction Attendant Help	4
Overview	4
Organization of Help Topics	4
Graphics in this document	5
Icons in Topic Titles identify Toolbar and Menu Commands	5
Attendant Concepts	6
Advantages of Interaction Attendant	6
How does Attendant work?	6
How does the user interface work?	8
Tree Pane	9
Nodes	9
Property Sheets	10
Hierarchical Relationships in the Tree	10
Tasks that Attendant can perform	12
Call Flows	13
Basic steps to build a Call Flow	13
Attendant Commands	14
Summary	14
Pull-Down Menu Commands	14
File Menu	14
Edit Menu	15
View Menu	16
Insert Menu	16
Help Menu	17
Context Menu Commands	17
Attendant Concepts	18
Advantages of Interaction Attendant	18
Handlers used by Interaction Attendant	19
Procedures	19
Install Interaction Attendant	20
Rights required to use Attendant	20
Start Interaction Attendant	24
Manage Nodes in the Tree	33
Manage Voice Prompts	51
Manage Configuration Files	66
Working with Speech Recognition	75
Configure Remote Monitoring	83
Disconnect from a Server	85
Exit Attendant	85
Set up Skills-based routing in Attendant	85
Set Up Voice Mail Distribution in Attendant	86
User Interface Options	86
Servers	87
Profiles	87
Schedules	105
Operations	133
Dialogs	259
Dynamic Call Attributes	321
Eic_AttrCallbackCopyAttributes	321
Eic_AttDynamicSkillstoAdd	322
Eic_AttDynamicSkillsToRemove	322
Eic_AttDynamicUserVmail	322
Eic_AttDynamicWorkgroupVmail	322
Eic_AttDynamicWorkgroupName	322
Eic_AttDynamicWorkgroupSkills	322
Eic_AttDynamicWorkgroupPriority	322
Eic_AttDynamicAgentName	322
Eic_AttDynamicExternalNumber	322
Glossary	322
ANI	322
Audio Prompts	323

Attendant Configuration File	323
Audio Playback	323
Auto Attendant	323
Auto Attendant Processing	323
Backup Export	323
Call Attribute	323
Call Flow Configuration	323
Call Processing Style	324
Current Language	324
Customer Interaction Center (CIC)	324
Default Action	324
Default Language	324
Default Node	324
Dial by Name	324
Direct to Queue Processing	324
DNIS	324
Full Export	325
CIC Server	325
Dial Extension	325
External Transfer	325
Fax Back	325
Handler	325
Incoming Call Selection	325
Interaction Attendant	325
Interaction Designer	325
Interaction ID Key	325
IVR	325
Line Name	326
Menu	326
Menu Entry	326
Menu Transfer	326
Node	326
Notifier	326
Operations	326
Profile	326
Profile Telephone Number	326
Queue	326
Queue Transfer	327
Receive Fax	327
Remote Voice Mail	327
Schedule	327
Station Groups	327
Station Queue	327
Submenu	327
Subroutine Initiator	327
Template Export	327
Trunk	327
User Queue	327
Voice Mail Transfer	328
Change log	329

Interaction Attendant Help

Interaction Attendant is an easy-to-learn program that configures the auto attendant system built into Customer Interaction Center. It automatically answers a call and then it presents the caller with menu choices. Then it routes the call according to the caller's choice.

This publication explains how to use Interaction Attendant to manage menus that callers navigate when they telephone your business, and automation that responds to incoming faxes and e-mail. No post-installation tasks are required to make Attendant operational. When [Setup Assistant](#) ends, Attendant is fully configured and operational on the CIC server. However, most users [install](#) Interaction Attendant on their local hard drive. Interaction Attendant is an *IC Server Manager* application.

Overview

Interaction Attendant allows the auto attendant designer to link together predefined operations to create simple or sophisticated menu applications without writing or modifying handlers. Non-programmers can create and manage menu interactions by filling out and linking forms in Attendant. Customers who need auxiliary business logic can develop custom handler subroutines in Interaction Designer, and call these subroutines in Attendant.

Interaction Attendant is precise. Calls are compared to user-defined profiles that determine the scheduled processing that will occur. Attendant provides complete call control without sacrificing features. For example, Interaction Attendant can:

- Play prerecorded messages, route call to queues, send and receive faxes, or transfer to voice mail.
- Present a different set of menu options during non-business hours or holidays.
- Look up information in a database, pass control to a submenu, integrate with a CRM, or perform dozens of call control operations, ranging from screen pop to automated e-mail processing.
- With CIC, your communications system adapts to the way you do business, not the other way around. You can customize CIC using Interaction Attendant only, handlers, or both. Using Interaction Attendant exclusively, it is easy to create sophisticated auto attendant systems that require minimal staff training and minimal technical support. Customers who compose handlers to automate business processes can achieve even higher levels of customization by integrating custom subroutines with Attendant.

Organization of Help Topics

This publication, like Attendant itself, was developed with non-programmers and administrators in mind. General familiarity with Microsoft Windows and with the PureConnect platform is assumed. However, no programming experience is required. This documentation is organized into sections that may be read in order. Topics are hyperlinked to allow non-linear navigation.

[Attendant Concepts](#) - How Attendant works.

[Procedures](#) - Instructions for completing common tasks.

[User Interface Options](#) - Details about property pages and dialogs in Interaction Attendant.

[Glossary](#) - Special terms used in Interaction Attendant documentation.

Document Revision History - Summary of documentation revisions.

Rev 8/5/2020



Graphics in this document

Screen Shots

Most of the graphics in this publication are partial images of forms (called property sheets) that you can fill out in Attendant. Rather than include the complete image of a form in the topic that explains it, partial screen shots are provided instead. This prevents pages from being overwhelmed by large graphics, and makes it easier to locate the explanation of individual visual elements.

The sectional portions of a form are represented by graphics with beveled edges. You may need to scroll a page to locate help for the form section you are interested in. In most cases, everything about a form is explained in one topic.

Hiding Large Graphics in Online Help

The online edition of this publication allows large graphics to be hidden by pressing the *Hide Large Graphics* button () in the page header. This allows you to view more text in the help window at one time. To redisplay all graphics, press the *Show Large Graphics* button ().

Icons in Topic Titles identify Toolbar and Menu Commands

All commands in Interaction Attendant are invoked by pressing toolbar buttons, or by selecting menu options. Each command is documented in its own help topic. The icon that represents each command appears in the topic that explains it. In the figure below, the explanation of "Dial by Name" identifies the icon used in toolbars and menus to invoke the command.

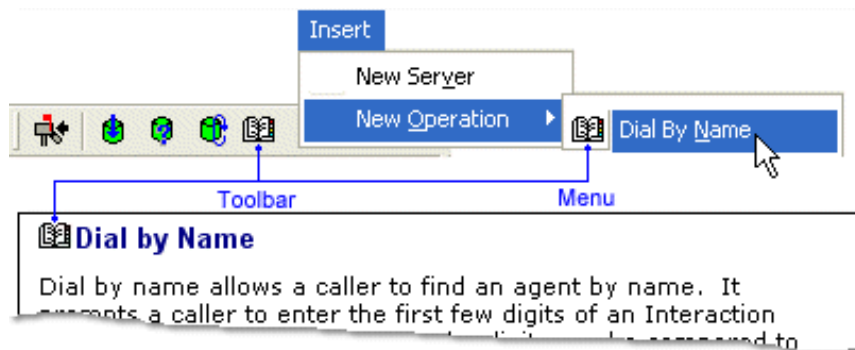

Attendant Concepts

Interaction Attendant configures the auto attendant system built into [Customer Interaction Center](#). An *auto attendant* automatically answers a call. It prompts the caller to make [menu](#) choices, and routes the call according to that caller's choice. Callers select options by pressing keys on their telephone's keypad. Based on these interactions, the auto attendant can:

- Play prerecorded prompts
- Transfer calls to an agent, operator, queue, or voice mail
- Look up information in a database
- Dynamically convert text to speech
- Offer a sub menu
- Send or receive a fax
- Provide access to voice mail
- Search an employee directory, and more.

Interaction Attendant provides complete control over what happens when each key is pressed. For example, you might play a prerecorded message, route the call to a queue, send a fax, look up information in a database, or pass control to a submenu. Interaction Attendant's predefined operations can be linked together any way you wish to create sophisticated menu applications.

Attendant empowers non-programmers to manage the interactions that callers encounter when they phone your business. Menus, operator access, direct dialing, and dial-by-name services are configured by filling out forms in Attendant. Customers manage call flows without having to customize handlers.

With CIC, your communications system adapts to the way you do business, not the other way around. If you need custom business logic that Attendant does not offer, you can extend its functionality by developing custom handlers. Handlers are created outside of Interaction Attendant using *Interaction DesignerTM*—CIC's visual programming tool. Handlers extend the PureConnect platform to meet unique business requirements. They can perform just about any conceivable data processing task. But most customers find that Attendant provides all of the tools that they need to create robust IVR interactions.

Advantages of Interaction Attendant

- Interaction Attendant was written for *non-programmers*, with a non-system administrator in mind. It is easy to use, yet powerful. You can create sophisticated IVR menus with it.
- Interaction Attendant is *visual*. It displays hierarchical relationships between configuration objects, and flags errors before configurations are published. This makes the system easy and safe to use.
- Interaction Attendant doesn't require special hardware. Voice prompts are recorded within Attendant using a station phone.
- Interaction Attendant is *flexible*. Configurations can be published to a server, exported to a file, or imported from a file. A single instance of Attendant can edit the auto-attendant configuration of many CIC servers. Attendant keeps track of who is editing each configuration and locks files to prevent conflicts.
- Interaction Attendant is *robust*. It provides the ability to control calls after they have been routed to a workgroup queue. It offers advanced scheduling mechanisms, database functionality (insert, query, update) and sophisticated profile-based routing. You can gather information from a caller, and write it to a database, or use caller-entered data in another menu interaction. For example, you might ask a user to enter a PIN number and then use it to look up an account balance that is read back to the caller.
- Interaction Attendant is *extensible*. It can invoke custom handlers for unlimited functionality. However, the primary benefit of Attendant is that it allows users to design simple call flows without writing handlers.
- Interaction Attendant is *precise*. Calls are compared to user-defined profiles that determine the scheduled processing that will occur. For example, inbound calls can be filtered using DNIS, ANI, and/or trunk line information associated with the call. Afterwards, schedules select the most appropriate call processing based upon the time of day. For example, persons who phone your company after business hours can be presented with different options from those that are presented during daytime hours. IVR interactions can be customized to any extent required by the customer.

How does Attendant work?

In a nutshell, here's how Attendant works:

Interaction Attendant uses *profiles* and *schedules* to determine which *operations* it should perform to interact with a contact. The basic steps are as follows:

1. The IC server gives Interaction Attendant a call to process. Most often, this is an inbound call, or a call that was routed to an operator. But it could be an outbound call that was placed by Interaction Dialer or a custom telephony application.
2. Attendant analyzes the call to accumulate information about it. It determines whether the call is inbound or outbound. If the

call is inbound, it acquires the telephone number that was dialed (DNIS), the caller's telephone number (ANI), and the line or line group that the call is on.

3. Attendant compares these call characteristics to predefined **profiles** for that server. It gives control over the call to the profile that most closely matches the call.

A *profile* is a collection of predefined call characteristics that Attendant compares to an interaction, to figure out how to process it.

Profiles are best understood by example. Suppose that your company offers two levels of technical support: Silver and Gold. Silver members call 555-1111, and Gold members call 555-2222. To tell Attendant how to handle support calls, you would use Attendant to create an inbound profile for each telephone number. For now, don't worry about how that is done.

Each profile filters calls to match one of the numbers. When callers dial 555-2222, their call is processed by the profile for Gold support. When callers dial 555-1111, their call is processed by the profile for Silver technical support. In this scenario, Attendant uses *Dialed Number Identification Service* (DNIS) to determine the number dialed. Since Attendant knows the dialed number, it can perform unique processing on the call. For example, it might play special messages or offer alternate menu choices.

The main idea is that profiles are compared to calls to see if the call matches a profile characteristic of some sort. E.g.: Was this particular number dialed? Did they call our 800 number? You can define as many profiles as you wish. Let's look at another scenario.

Suppose that Marketing needs special call routing. They want to automatically route calls from their biggest customer directly to the person who manages that account. To catch these calls, you would define a profile that examines the caller's telephone number, rather than the number dialed. A profile of this type uses a process called *Automatic Number Identification*, or ANI for short. ANI is sometimes called Caller ID, and it is the opposite of DNIS. DNIS indicates the number that was called. ANI provides the caller's telephone number.

Profiles don't have to be very specific. They can examine a wide range of incoming call characteristics, using wildcards, and a combination of ANI, DNIS, and line criteria. When a profile is evaluated, the logical OR operator is used. If more than one criterion is specified, the interaction matches the profile if any of the profile's criteria are met. But what happens if you don't create a profile for every conceivable type of call?

The answer is that Attendant provides a **default profile** that catches calls that don't match user-defined profiles. You can customize a default profile to play a wave file, but its filtering criterion are disabled. This insures that the default profile will match all calls that get past your custom profiles.

4. Since profiles merely set up comparisons, they do not carry out actions, such as transferring a call. The tasks that Attendant can perform are called **operations**. Operations do work of some sort, such as prompting a caller to enter an account number, or reading back an account balance that was retrieved from a database.

But, what if your best customer calls at midnight, when the account rep is not there? Or, what if someone calls Technical Support on Christmas, when the entire company is on holiday? What if it snows, and you have to suspend operations for a day or two? As you can see, operations are time-sensitive. Attendant handles these considerations rather nicely. Once a matching profile is given control of a call, Attendant evaluates **schedules** to select an appropriate set of operations to perform.

A *schedule* determines whether a menu of operations is active, based upon a date, range of dates, time, or special event.

A profile may have many *schedules* attached to it. Schedules stipulate when a menu of operations can run. You can define schedules to handle recurring events, holidays, or special situations, such as your regular business hours, after-hours support, or an office closing due to poor weather conditions. But what if you don't think of every contingency?

You guessed it—every profile has a **default schedule**. Attendant creates it for you automatically. The menu attached to a default schedule is given control of the call when no other schedule in the profile has precedence.

A default schedule ensures that all calls are processed, should a call arrive during a period that is undefined by custom schedules.

Since the default schedule is designed as a catch-all, you can't edit it to define a start or end date, or to specify daily, weekly, monthly, yearly, unplanned, or system events. Those items can only be configured in a custom schedule form.

5. When call flow is passed to a schedule, the schedule's menu operations are executed. Up until now, call processing has been largely invisible to callers. But from this point forward, callers interact with menu operations attached to the schedule. You've probably guessed that Attendant allows you to define as many schedules as you need to perform whatever actions are appropriate for a given date, time, or situation.

You can even set up *unplanned schedules* and activate them over the phone. For example, you might create an unplanned schedule for a "snow day" to tell customers that your business is closed. In a weather emergency, you can **remotely activate** the schedule from home.

Menus are created when you associate *operations* with a *schedule*. Attendant provides dozens of operations that help you build menus. For example, you can create menus that allow callers to dial by name, dial by extension, or transfer a

call. Attendant even provides an operation that creates a submenu. However, Attendant is not limited to mundane tasks. For example, it can obtain data from a caller, look up information from a database, and update records. If you need functionality that Attendant does not offer, you can call custom handlers from Attendant. Handlers are custom programs created using Interaction Designer—the CIC's visual programming tool. Handlers can perform just about any conceivable data processing task. They extend the PureConnect platform to meet unique business requirements. But most people find that Attendant provides all of the tools that they need to create robust IVR interactions.

Related Topics

- [Procedures](#)
- [User Interface Options](#)

How does the user interface work?

Let's examine Interaction Attendant's user interface, to see how profiles, schedules, and operations are implemented in the software. The figure below shows an inbound call flow:

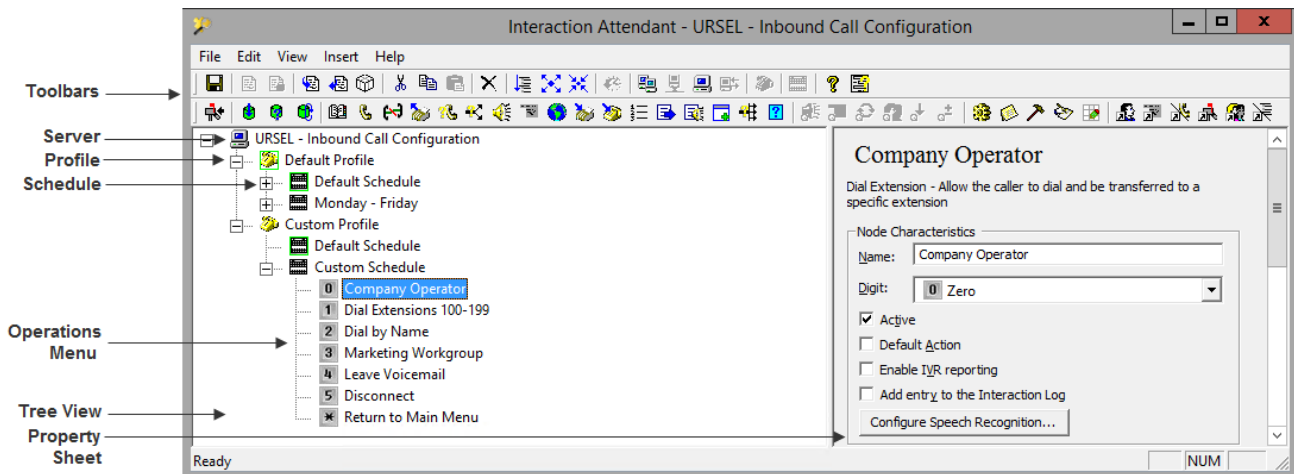

Since Interaction Attendant is a utility for configuring CIC's auto attendant, its user interface is designed to help you construct automated attendant menus. A menu is a collection of one or more operations that process calls based on the keys a caller presses. A caller chooses menu entries by pressing keys on a telephone. Based on the caller's choice, an auto attendant will offer a submenu, transfer a call to a queue, allow callers to search an employee directory, send or receive a fax, or perform many other actions.

A menu is attached to a schedule that determines when the menu will run. A schedule is attached to a profile, which examines incoming calls to select calls to process. A server has one default profile and one default schedule, and may have any number of custom profiles and schedules

Attendant's visual metaphor is effective. It displays profiles, schedules, and operations for multiple servers and different [call flows](#) in a *Tree* pane on the left side of the display. The right side of the screen displays a property sheet for the currently selected [node](#). Subsequent topics discuss these items in more detail.

Related Topics

- [Tree Pane](#)
- [Nodes](#)
- [Property Sheets](#)
- [Hierarchical Relationships in the Tree](#)

Tree Pane

Interaction Attendant's *tree pane* visually displays the design of auto-attendant menus. It displays [profiles](#), [schedules](#), and [menus](#) for each server in a hierarchical arrangement. You must be [connected](#) to a CIC server to see its call flow configuration (schedules, profiles and menus). The tree displays an inbound, outbound, or operator [call flow](#).

Splitter Bar

You can narrow or widen the tree by clicking and dragging a splitter bar to a new horizontal position.

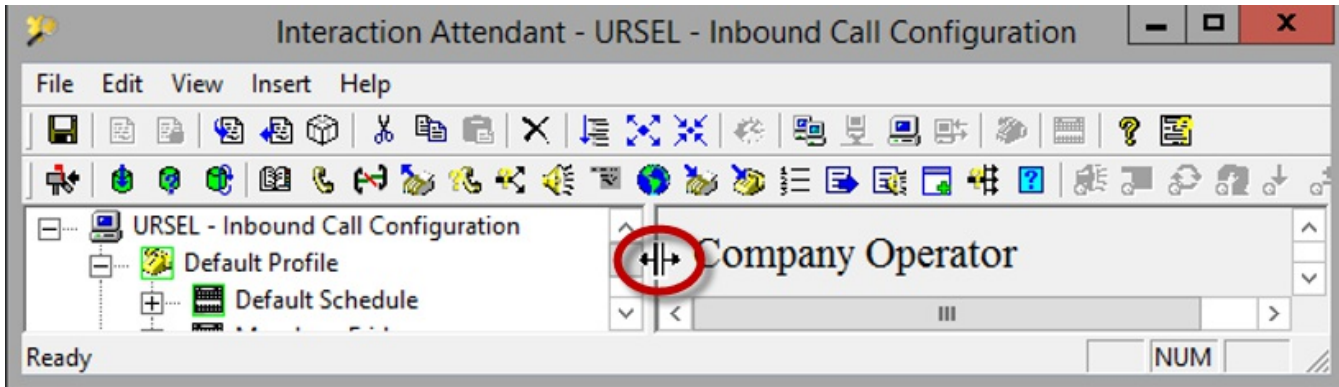

Related Topics

- [How does the user interface work?](#)

Nodes

A *node* is an item in the tree that you can select for editing. Interaction Attendant supports four types of nodes:

1. *Server* nodes organize the configuration of connected servers. All interactions for a given call flow type appear below its server node in the tree. To add a server to the tree, issue a [connect](#) command and specify the server name, user name, and password. You can also connect to a server by importing an [Attendant Configuration file](#).
2. *Profiles* define characteristics that are compared to incoming calls. Profiles are compared to call characteristics to select the best matching profile. Afterwards, its schedules are evaluated to appropriately process the call. Every server has a default profile that is used when no other profiles are defined, or have precedence. Default Profiles are generic and do not filter out calls. Custom profiles select calls based upon a variety of criteria.
3. *Schedule* nodes determine whether an attached menu is active, based upon the date, time of day, or an event. Schedules are always attached to Profiles. Interaction Attendant automatically creates a Default Schedule, and executes its menu when no other schedule has precedence.
4. *Operations* are menu actions that Interaction Attendant performs in response to a keystroke entered by the caller or in response to a system event.

When profiles, schedules, or operations are added to the tree (using menu commands or toolbars), they are called *nodes*. Call flows are constructed by adding nodes to the tree. When you click on a node in the tree, you can edit its properties on the right side of the screen. To build a menu, one adds, arranges, and configures nodes in the tree. See [manage nodes](#) for procedural information.

Nodes displayed at startup

At startup, the tree expands automatically to reveal schedules and profiles, but not menus. This presents an appropriate level of detail, especially if the tree contains many profiles, schedules, and menus.

Related Topics

- [How does the user interface work?](#)

Property Sheets

When a node is selected in the tree view, its Property Sheet is displayed on the right side of the screen. A property sheet is just a form that you fill out to configure a node. For example, you name a node by filling in the Name field on its property sheet. Each type of node has its own unique property sheet.

Edits are cached until you publish or discard them

The changes you make to a property sheet are retained if you edit another node. Interaction Attendant saves changes at the server level—that is, it saves the changes you make to the entire server configuration at one time. If you click on another node, Attendant remembers changes that you have made. Changes do not go into effect until you [publish](#) them.

Related Topics

- [How does the user interface work?](#)

Hierarchical Relationships in the Tree

Attendant enforces a hierarchical relationship between nodes in the tree. It uses simple rules to determine the order of items, and the options that are available in menus and toolbars. The figure below shows the relationship between servers, profiles, schedules, and operations. The basic structure is: Server > Profile > Schedule > Operation.

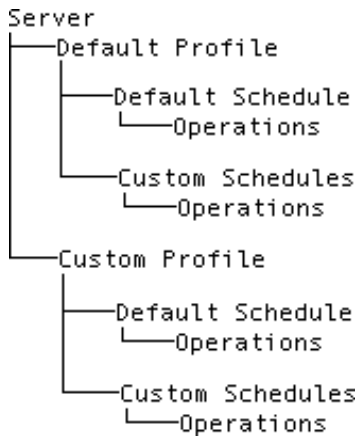

The highest-level node is a **Server** that you have connected (logged in) to. If you connect to more than one server at a time, nodes for servers are siblings in the tree.

Attendant attaches a default **Profile** below each server, to processes calls that do not match custom profiles. When you add your own custom profiles to filter calls based upon ANI, DNIS, Line Group, Line, and other criterion, they are listed at the same level as the default profile.

Schedules are attached below profiles. Attendant attaches a default schedule to each profile, in case none of your schedules are selected to process the call.

Operations are attached to schedules (and in a few cases, to other operations). You can add as many operations as you want to build each menu. The lowest-level items in the tree are the operations that Attendant performs when a caller presses a key. One example of an operation is playing back an audio file. A digit symbol appears next to each operation in the tree, so that you can visually see which key the user must press to select the operation.

Related Topics

- [How does the user interface work?](#)

Simple rules govern the tree

Simple rules determine the order of items in the tree, and the options that are available.

Toolbars and menus are enabled or disabled based upon selections you make in the tree

- Server nodes are topmost in the tree. You can't insert a profile, schedule, menu, or operation unless you are connected to a server and have selected the name of a server in the tree.
- To insert a new profile, a server or existing profile must be selected in the tree.
- To insert a new schedule, a profile or existing schedule must be selected in the tree.
- To insert an operation, a schedule or existing operation must be selected in the tree.

Menu operations are the lowest items in a logical hierarchy

- Operations are attached to menus (a schedule is also a menu).
- Menus are attached to Schedules.
- Schedules are attached to Profiles.
- Profiles are attached to Servers.

The hierarchical relationship of items relative to one another is determined as follows

- Whenever possible, new nodes are inserted as children. Otherwise, nodes are inserted as siblings.
- An inserted item becomes the last child of the selected node, if the selected node supports children. If you select a menu, and add an additional operation to it, the operation is added as the last child of the menu.
- If the selected node does not support children, the new node is added as a sibling. For example, if you select a default profile, and add a new profile, the new profile has a sibling relationship to the default profile. The profile form allows schedules to be added as children, but you can't add a profile as a child.

Related Topics

- [How does the user interface work?](#)

Tasks that Attendant can perform

Interaction Attendant's powerful, easy-to-use interface makes it easy to develop auto-attendant menus for an enterprise or call center. Here's a sampling of what can be done:

- You can customize the way in which inbound calls are answered (via [DNIS](#), [ANI](#) or [line name](#)) by creating unlimited menu levels and menu transfers.
- You can edit menus, schedules, and profiles for many CIC servers at once. Profiles, schedules, and menu operations are displayed in an easy-to-understand tree structure. The tree visually indicates when someone else is editing the server configuration. In addition, errors and default conditions are visually flagged using special icons and colors.
- You can record prompts using an ordinary telephone. Prompt playback is supported in most menu operations.
- Menu configurations can be imported and exported. You can easily back up a server configuration and restore it later.
- Attendant's database operations allow you to interact with data sources. For example, you can prompt users to enter data and save their entries in a database.
- Answering can be customized according to time sensitive parameters: month, day, day of week, hour, or minute for after hours / holiday call routing. Using the Logical Transfer operation, you can branch to menus based on data entered by a caller, data about the current call, the current time, data about a workgroup, or data in a database.
- You can schedule menus to run at different times or schedule menus based on incoming call criteria, such as DNIS, ANI or line information. You can create unscheduled menus and activate them from a touch-tone telephone.
- You can route calls to any system workgroup (ACD, hunt, standard), user queue, or station queue.
- You can play an audio file in response to a particular menu option.
- You can prompt the caller to enter data, such as a FAX number.
- You send a FAX to a number entered by a caller.
- You can receive FAX transmissions. Automatic FAX Detection at a menu allows a workgroup or main number to function as a fax number as well.
- You can route a call to the appropriate unified messaging inbox (Voicemail / Email / fax).
- You can transfer a call to an external number.
- You can customize voice prompts and record greetings.
- You can direct calls to the Dial by Name subsystem.
- Flow-of-control is configurable. You can define error handling at the schedule and form level, and use "Action when Finished" branching options. When a menu operation finishes, you can return control to the previous menu, disconnect, or pass control to any profile, schedule, or menu you define for the current server.
- You can interface with the CIC's powerful handler customization subsystem by sending a call to an Interaction Handler from a menu option.

Related Topics

- [Procedures](#)
- [User Interface Options](#)

Call Flows

Attendant manages three types of *call flows* (inbound, outbound, and calls to the operator). Configurations for a given call flow type are displayed in the tree view. If you connect to more than one server, call flows for that type (inbound, outbound, or operator) appear in the pane. For example, the inbound call flow tree might contain icons for several connected servers.

If you do not use a command-line switch to select a call flow, the inbound call flow is loaded by default. See [Start Interaction Attendant](#) for more information about command-line parameters.

Access to call flows is rights-based. If you do not have rights to edit a call flow type (inbound, outbound, or operator), you cannot view configurations of that type in the tree. See [Rights required to use Attendant](#).

- **Inbound** call flows are most commonly defined. Inbound profiles analyze an incoming call to figure out which schedule best applies. The call is then routed to the most appropriate IVR interaction.
- **Operator** call flows are auto-attendant menus that process calls to the operator. They are similar to inbound call flows, but use different call selection criteria. Inbound call profiles select calls based upon ANI, DNIS, and line information. Operator call flows examine the queue or Attendant profile that the call came from. Operator call flows are managed separately, in their own pane. The nodes that control processing of operator calls are not intermixed with nodes that process other call flows. This makes it easier to visualize and manage operator call processing.
- **Outbound** call flows process calls that have been placed and which are already connected. For example, an Outbound call flow might process a call that Interaction Dialer placed to someone in a contact list. You can connect Custom Outbound Call Schedules to an outbound profile, and then use call analysis information in the schedule to route the call to menus that are tailored to interact with live persons, answering machines, or Fax machines. If the Outbound profile is configured for Direct-to-Queue processing, the connected call is routed to a user, station, or workgroup queue, or to any outbound profile defined for that server. Outbound call flows add a new dimension of call processing capability to the CIC environment.
- **Email** call flows implement simple routing rules based upon the senders' address or domain, or based upon words or phrases used in an Email. Skills and priorities can be set, and routing assigned to selected workgroups. Interaction Attendant provides Email-specific profiles, schedules, and operations

Related Topics

- [Manage nodes in the tree](#)
- [Rights required to use Attendant](#)
- [Start Interaction Attendant](#)

Basic steps to build a Call Flow

Servers, Profiles, Schedules, and Operations

When you connect (login) to a server in Attendant, Attendant adds a node for that Server to its tree. The Server node is an conceptual device that Attendant uses to organize call processing configurations for that server. Nodes below the server select calls to process, select the most timely menu, and interact with the caller:

- Profiles select calls to process.
- Schedules pass control to the menu that best matches the time of day, current date, range of dates, or special event, such as a snow day.
- Operations carry out work in accordance with Schedules. Operations build the menus that callers interact with.
- Once you understand the relationship between servers, profiles, schedules, and operations, you can begin building interactions in Attendant. The basic steps are:
 1. [Start Attendant](#) (using [command-line parameters](#) if desired)
 2. [Connect to the server](#) whose IVR interactions you want to edit. Once connected, its configuration appears in the tree below a server node.
 3. Expand the server node.
 4. Select nodes that you wish to edit, or add child nodes to.
 5. Add profiles, schedules, or operations as needed.
 6. Fully configure each node by completing its property sheet.
 7. [Publish](#) your configuration, or [export](#) it to a file that you can load in later to finish.

Related Topics

- [Procedures](#)
- [User Interface Options](#)

Attendant Commands

All commands in Attendant are issued by selecting from pull-down menus, or by pressing toolbar buttons. Attendant supports a few context menus also. To control the program, there are no commands to memorize, or type in.

Summary

Interaction Attendant's user interface is designed to manage auto-attendant menus. A menu is a collection of one or more entries (operations) that process calls based on the keys a caller presses. A caller chooses menu entries by pressing keys on a telephone. Based upon the caller's choice, the auto-attendant will offer a submenu, transfer the call to a queue, allow callers to search an employee directory, send or receive a fax, or perform other operations.

When you [connect](#) to a server, its auto-attendant menu configuration is loaded into Attendant for editing. Attendant also retrieves other details from the server at this time, such as information about lines, workgroups, and users. Whenever you modify a menu configuration, your changes are not saved or put into effect until you [publish](#) them.

Attendant's user interface is straightforward. A tree on the left allows a node to be selected for editing. The properties of the selected node appear are edited on the right side of the screen. To view or edit the properties of another node, select another node in the tree.

A *node* is an item in the tree. Usually this is an operation, such as playing an audio file for the caller. Some nodes are containers for other nodes. The Server node, for example, organizes configuration settings for a CIC server.

Related Topics

- [Pull-Down Menu Commands](#)
- [Context Menu Commands](#)

Pull-Down Menu Commands

Pull-down menus in Interaction Attendant allow you select commands quickly. These menus organize all of the commands that Interaction Attendant recognizes.

File Menu

File commands that connect or disconnect from CIC servers, export Attendant (*.att) configuration files, or close the application.



Connect

Opens a login dialog. Once the login is validated, Attendant adds a server node to the tree. The Connect command allows you to administer multiple servers and see them all in the tree view.



Disconnect

Disconnect releases the connection between Interaction Attendant and an CIC server. See [disconnect from a server](#).



Publish

This command saves changes made to menu configurations, and puts them into effect. See [publish a configuration](#).



Import File

Import loads an Attendant configuration file into the interface for editing. See [manage configuration files](#).

Export File

Export saves an Attendant configuration file to disk. See [manage configuration files](#).

Package...

This option is similar to export, but instead of exporting all nodes in the tree, it exports the selected node along with any children it might have. Unlike configurations, which save all nodes of the call flow to a file, package files contain a selected portion of the call flow. See [manage configuration files](#).

Exit

This command closes Interaction Attendant. You may be asked to [save changes](#). See Exit Attendant for more information.

Edit Menu

Edit commands manage servers, cut, copy, paste, sort, rename, or delete items in the tree structure.

Manage Servers

This command opens the [Manage Servers dialog](#) so that you can apply publish, export, refresh, and disconnect commands to multiple connected servers at once. You can also connect to additional servers from this dialog.

Cut

The Cut command removes the selected node, and places a copy on the system clipboard. You can cut and paste tree nodes. Cut deletes a selection and places a copy on the clipboard.

You can drag and drop or cut/copy/paste nodes from one area to another. However, Interaction Attendant won't let you drag nodes from one server to another, or to paste nodes from one server to another. All node movement is restricted to the current server. Interaction Attendant also checks to see if the dropped/pasted node is assigned to a digit that is already in use by an existing node in the menu. If the new node is assigned the same digit as an already existing node, The dropped/pasted node's digit is reassigned to <none>.

Copy

Copies a selection to the clipboard.

Paste

Pastes an item from the clipboard to the control that has focus.

Multi-Language Prompts

Opens the [Prompt Management dialog](#), which allows any prompt to be selected to find out what languages the prompt has been recorded in. Prompts can be recorded in additional languages directly from this dialog. This dialog does not set the language used to play back a prompt. See [manage voice prompts](#).

Sort Tree

This command reorders items in the tree structure according to precedence. Schedules and menu options are sorted based on the time in which they are active. See [sort the tree](#) for procedural details.

Rename

This command renames the selected node in the tree structure.

Delete

This command deletes the selected node from the tree structure.



Refresh Server Data

This command polls each connected server to retrieve information about workgroups, schedules, users, stations, skills, DB sources, lines, line groups, schedules, languages, and the default language.



Disconnect Server

This command releases the Notifier connection to the server whose node is selected. In effect, this "logs off" Interaction Attendant from a server. This option is disabled until a server node is selected in the tree.



Load Active Configuration

This command abandons changes that you have made and reloads the configuration that is currently active and taking calls on the selected server.

View Menu

View commands toggle the display of status and tool bars.

✓ Toolbar

Toggles display of the main toolbar on or off. The main toolbar provides pushbutton icons that are equivalent to the File, Edit and Insert menus. The operations toolbar is always available cannot be toggled on or off.

✓ Status Bar

This command toggles the status bar on or off. The status bar displays helpful information at the bottom of the screen when you "mouse over" a toolbar element or select a menu item.

Insert Menu

Insert commands add server, profile, schedule, or operation nodes to the tree.



New Server

This command opens the Interaction Attendant Login dialog so that you can [connect to an existing server](#).



New Profile

A profile is a collection of one or more menus. Interaction Attendant automatically creates default profiles for you. You can add your own custom profiles to filter calls using specific criteria. See [profiles](#).



New Schedule

A schedule stipulates when a menu can run. The *New Schedule* command adds a new Schedule node, so that you can specify when the menu will be initiated. See [schedules](#).

New Operation

Operations are actions that Interaction Attendant can perform in response to a menu selection. This cascading menu allows you to insert a new operation. See [operations](#).

Help Menu

Help commands open online help topics, web links, display version information and particulars of your computing environment. See [accessing context-sensitive help](#).

Context Menu Commands

You can right-click on nodes in the tree view to open Attendant's context menu. A context menu works like a pull-down menu to issue commands. The list of available commands vary based upon the type of object that is selected, or the status of that object. Inappropriate commands are disabled.

For example, if you right-click on a server, you can disconnect from it, but you cannot cut, copy, or paste. The figure below shows all available context menu commands. If you select *New Operation*, a submenu of available operations is presented. See [menu operations](#).

Related Topics

- [Commands](#)
- [Procedures](#)
- [User Interface Options](#)

Attendant Concepts

Interaction Attendant configures the auto attendant system built into [Customer Interaction Center](#). An *auto attendant* automatically answers a call. It prompts the caller to make [menu](#) choices, and routes the call according to that caller's choice. Callers select options by pressing keys on their telephone's keypad. Based on these interactions, the auto attendant can:

- Play prerecorded prompts
- Transfer calls to an agent, operator, queue, or voice mail
- Look up information in a database
- Dynamically convert text to speech
- Offer a sub menu
- Send or receive a fax
- Provide access to voice mail
- Search an employee directory, and more.

Interaction Attendant provides complete control over what happens when each key is pressed. For example, you might play a prerecorded message, route the call to a queue, send a fax, look up information in a database, or pass control to a submenu. Interaction Attendant's predefined operations can be linked together any way you wish to create sophisticated menu applications.

Attendant empowers non-programmers to manage the interactions that callers encounter when they phone your business. Menus, operator access, direct dialing, and dial-by-name services are configured by filling out forms in Attendant. Customers manage call flows without having to customize handlers.

With CIC, your communications system adapts to the way you do business, not the other way around. If you need custom business logic that Attendant does not offer, you can extend its functionality by developing custom handlers. Handlers are created outside of Interaction Attendant using *Interaction DesignerTM*—CIC's visual programming tool. Handlers extend the PureConnect platform to meet unique business requirements. They can perform just about any conceivable data processing task. But most customers find that Attendant provides all of the tools that they need to create robust IVR interactions.

Advantages of Interaction Attendant

- Interaction Attendant was written for *non-programmers*, with a non-system administrator in mind. It is easy to use, yet powerful. You can create sophisticated IVR menus with it.
- Interaction Attendant is *visual*. It displays hierarchical relationships between configuration objects, and flags errors before configurations are published. This makes the system easy and safe to use.
- Interaction Attendant doesn't require special hardware. Voice prompts are recorded within Attendant using a station phone.
- Interaction Attendant is *flexible*. Configurations can be published to a server, exported to a file, or imported from a file. A single instance of Attendant can edit the auto-attendant configuration of many CIC servers. Attendant keeps track of who is editing each configuration and locks files to prevent conflicts.
- Interaction Attendant is *robust*. It provides the ability to control calls after they have been routed to a workgroup queue. It offers advanced scheduling mechanisms, database functionality (insert, query, update) and sophisticated profile-based routing. You can gather information from a caller, and write it to a database, or use caller-entered data in another menu interaction. For example, you might ask a user to enter a PIN number and then use it to look up an account balance that is read back to the caller.
- Interaction Attendant is *extensible*. It can invoke custom handlers for unlimited functionality. However, the primary benefit of Attendant is that it allows users to design simple call flows without writing handlers.
- Interaction Attendant is *precise*. Calls are compared to user-defined profiles that determine the scheduled processing that will occur. For example, inbound calls can be filtered using DNIS, ANI, and/or trunk line information associated with the call. Afterwards, schedules select the most appropriate call processing based upon the time of day. For example, persons who phone your company after business hours can be presented with different options from those that are presented during daytime hours. IVR interactions can be customized to any extent required by the customer.

Handlers used by Interaction Attendant

This topic discusses the relationship between Interaction Attendant and handlers. When you publish a configuration in Interaction Attendant, configuration data is written to the Directory Services section of in the Windows NT registry on the CIC server. When a call comes in, handlers look up this information and process it to perform the auto attendant interaction.

Warning—Interaction Attendant's functionality depends upon the handlers listed below. We do not recommend that you change any handlers whose name begins with *IntAtt*. Even small changes made to these handlers could cause your auto attendant menus to stop functioning.

The following handlers are used internally by Interaction Attendant. Please do not modify these handlers.

IntAttAcidAudio.ihd	IntAttAcidStatisticsInteraction.ihd
IntAttAcidStatisticsQueue.ihd	IntAttAgentTransfer.ihd
IntAttAttendantTransfer.ihd	IntAttAudioPlayback.ihd
IntAttCallerDataEntry.ihd	IntAttDBDelete.ihd
IntAttDBInsert.ihd	IntAttDBQuery.ihd
IntAttDBUpdate.ihd	IntAttDialByName.ihd
IntAttDialerCompleted.ihd	IntAttDirectProcessing.ihd
IntAttExpressionEvaluation.ihd	IntAttExtensionDialing.ihd
IntAttExternalTransfer.ihd	IntAttFaxBack.ihd
IntAttGetAudioPath.ihd	IntAttGetProfileKeyPath.ihd
IntAttGetScheduleKeyPath.ihd	IntAttIncomingCall.ihd
IntAttLogging.ihd	IntAttLogicalTransfer.ihd
IntAttManageUnplannedSchedules.ihd	IntAttProcessAcidWait.ihd
IntAttProcessError.ihd	IntAttProcessEvent.ihd
IntAttProcessMenu.ihd	IntAttProcessProfile.ihd
IntAttProcessQueueTimeout.ihd	IntAttProcessRelocation.ihd
IntAttPromptResource.ihd	IntAttReceiveFax.ihd
IntAttRecordPrompt.ihd	IntAttRemoteAccess.ihd
IntAttRequestCallback.ihd	IntAttSetAttribute.ihd
IntAttSubroutineInitiator.ihd	IntAttVoicemailTransfer.ihd
IntAttWorkgroupTransfer.ihd	IntAttAdvancedStatistics.ihd

For more information about handlers, refer the Interaction Designer online help.

Procedures

This section contains procedures that help you perform common tasks in Attendant. The major procedures are listed below:

- [Install Interaction Attendant](#) explains how to install Interaction Attendant on your personal computer.
- [Rights required to use Attendant](#) explains how the right to view or modify call flows is managed in Interaction Administrator. Access rights must be assigned to you by your system administrator before you can use Attendant.
- [Start Interaction Attendant](#) covers command-line parameters, call-flow configuration switches, and shortcuts used to run the program.
- [Connect to a Server](#) explains how to open the auto-attendant configuration of one or more servers for editing.
- [Manage Nodes in the Tree](#) explains how to use Attendant's visual metaphor effectively.
- [Manage Voice Prompts](#) explains audio controls and recording of voice prompts.
- [Manage Configuration Files](#) explains how to import, export, and publish auto-attendant configurations.
- [Configure Remote Monitoring](#) is for advanced users who are familiar with Attendant and Interaction Designer. This procedure explains how to configure remote continuous listening—a feature that allows a Supervisor to continuously listen, from a remote location, calls sent to queues that the Supervisor has rights to monitor.
- [Disconnect from a Server](#) explains how to release the Notifier connection between Interaction Attendant and a CIC server.
- [Exit Attendant](#) explains how to close Attendant safely.
- [Set Up Voice Mail Distribution in Attendant](#) explains how to configure a workgroup distribution list for voicemail distribution in Attendant.

Install Interaction Attendant

To install Interaction Attendant, run the **IC Server Manager Applications** install from the *IC_ServerManagerApps* share on your CIC server.

1. Locate the *IC Server Manager Applications* install, by navigating to the *IC_ServerManagerApps* share on your CIC server.
2. Double-click *ICServerManagerApps.msi* to run the install program. Then follow the on-screen instructions that appear.
3. The IC Server Manager Applications install includes the following applications:

- Interaction Designer
- Interaction Administrator
- Interaction Attendant
- IC System Manager
- Interaction Host Recorder Client
- SOAP Tracer

You may optionally select other applications to install besides Attendant.

Related Topics

- [Start Interaction Attendant](#)
- [Attendant Concepts](#)
- [Connect to a server](#)

Rights required to use Attendant

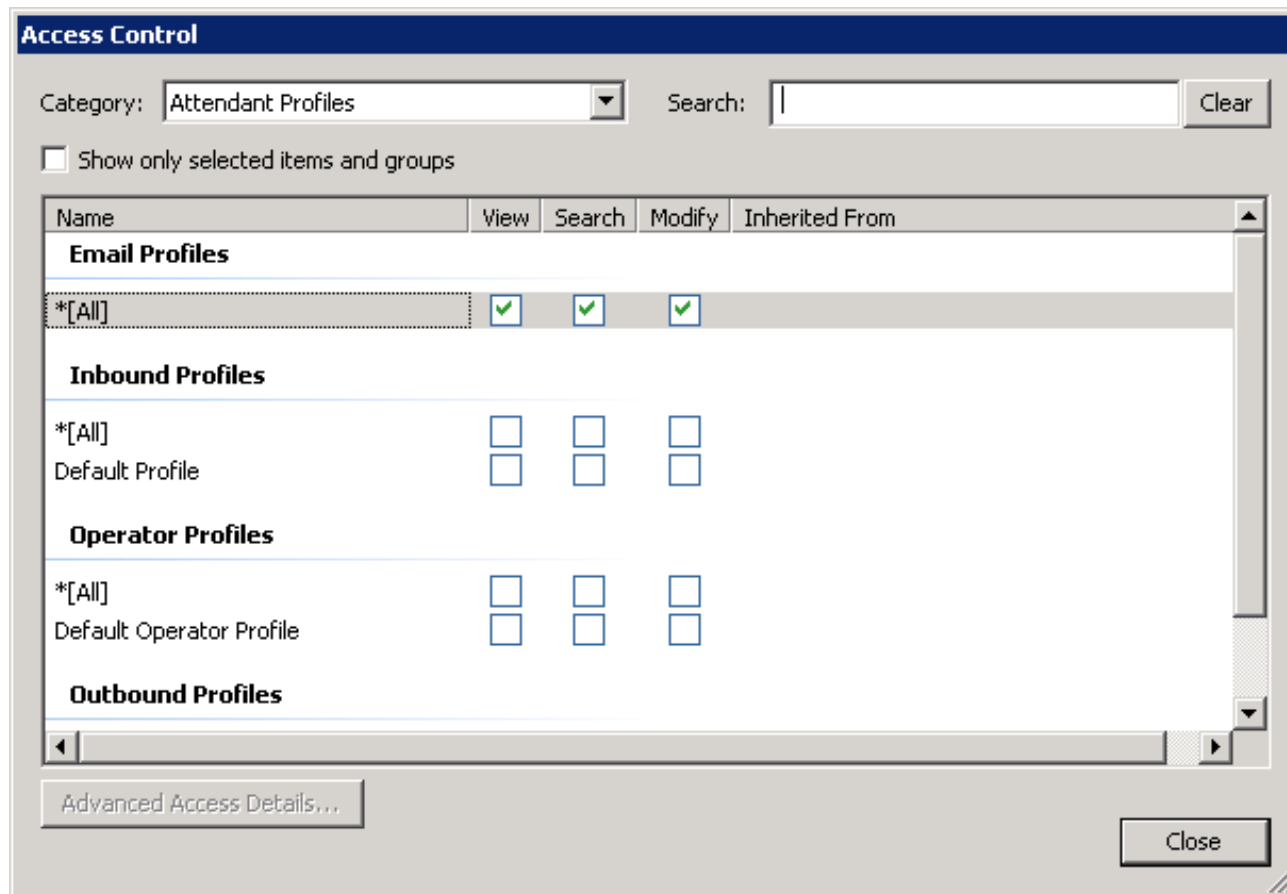

The right to view or modify Attendant configurations is configured outside of Interaction Attendant, in Interaction Administrator. Rights to view, search, or modify a [call flow](#) can be assigned at the Default User, Role, User, or Workgroups level. Rights are managed on the *Access Control* dialog box, located from the **Configuration-->Security tab-->Access Control** button in Interaction Administrator. The table below lists Access Control List (ACL) rights that pertain to Interaction Attendant.



Call Flow Type	Assignable Rights	Notes
Email	View Attendant Email Profiles Search Attendant Email Profiles Modify Attendant Email Profiles	<p>View rights grant read-only access to individual Profiles, or to all Profiles when *[All] is selected. A user who has read-only rights to an Attendant configuration cannot publish or export the server's configuration, and may not browse or record prompts (since doing so might change prompts stored on the server). Read-only rights are similar to access granted when another user has locked an Attendant configuration. The difference is that a locked configuration may be exported by the user, while a read-only configuration may not be exported.</p> <p>Search rights determine which Interaction Attendant profiles are available in the "Transfer to" box. Users who can view a profile have a lock on the Profile icon. A tool tip is displayed over the icon, explaining why the profile is locked.</p> <p>Modify rights grant the ability to view, modify, publish, and export Profiles within a call flow type. Administrators can restrict access to individual Profiles, or grant access to all Profiles by selecting *[All] for a right.</p>
Inbound	View Attendant Inbound Profiles Search Attendant Email Profiles Modify Attendant Inbound Profiles	
Operator	View Attendant Outbound Profiles Search Attendant Email Profiles Modify Attendant Outbound Profiles	
Outbound Profiles	View Attendant Operator Profiles Search Attendant Email Profiles Modify Attendant Operator Profiles	

See also: [Access Right Examples](#).

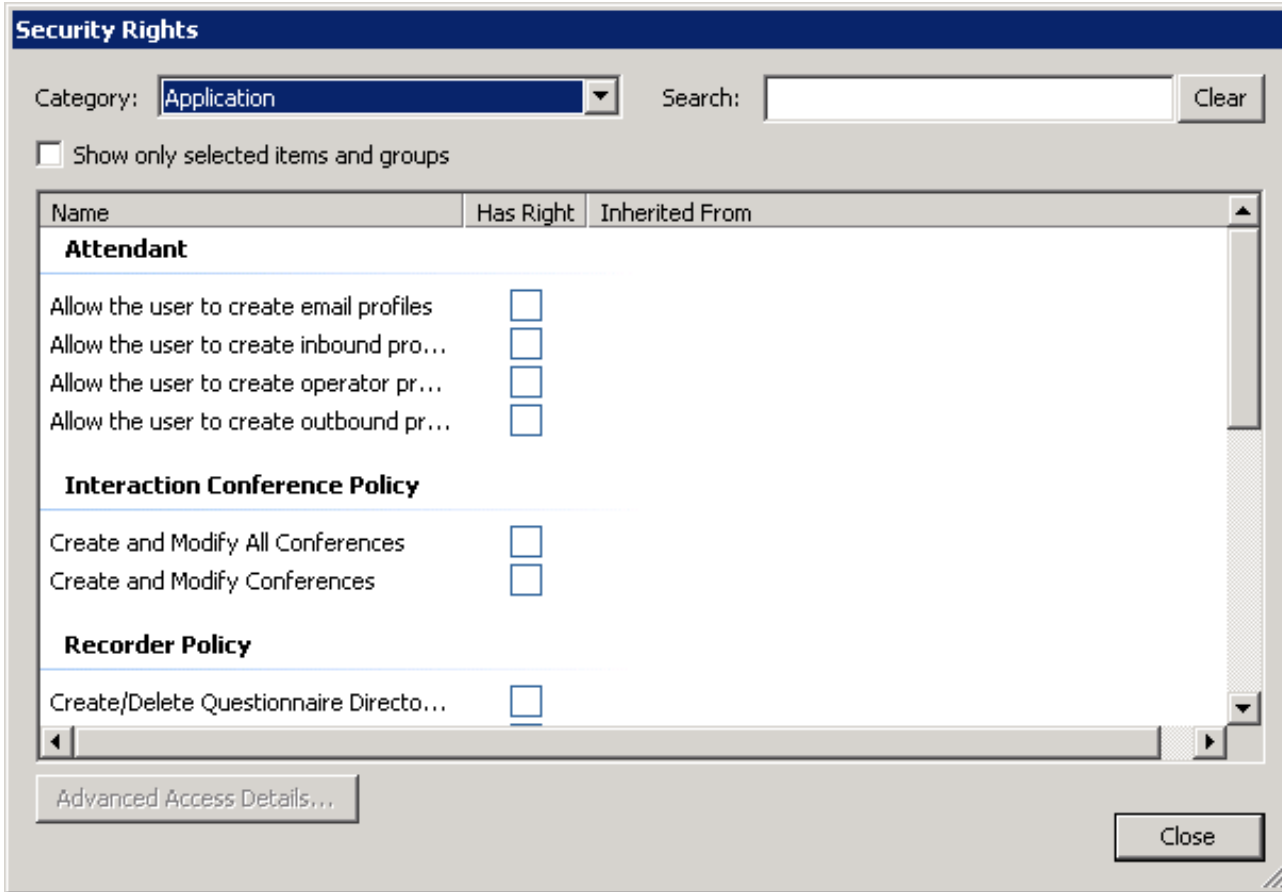
Create New Profiles



The right to create a new profile is also configured in Interaction Administrator, and they can be assigned at the Default User, Role, User, or Workgroups level. Create profile rights are managed on the *Security Rights* dialog box, located from the **Configuration-->Security tab-->Security Rights** button in Interaction Administrator. This dialog allows the Administrator to grant a user the rights to create inbound, outbound, operator, and email profiles. If you have the appropriate rights to create a new profile, Interaction Attendant also automatically grants you the rights to modify the profile. This feature allows you to edit any profile you create.

In Interaction Attendant, if the New Profile button ( for Inbound, Outbound, or Operator profiles or  for Email profiles) on the toolbar is greyed out, or the **New Profile** option located in the **Insert** menu is unavailable, you do not have the appropriate rights to create a new profile. See your administrator for information about obtaining your profile rights.

Access Right Examples

When enforcing access rights assigned to the user, Attendant will either:

- Not show a profile if the currently logged in user doesn't have access to it.
- Show the profile but with the lock icon and no changes can be made to that profile (and all child nodes) if the currently logged in user has view only access to it.
- Show the profile and changes can be made to it if the currently logged in user has modify rights to it.
- Disable a toolbar button or menu option if the user does not have the appropriate access rights. For example, if you do not have the appropriate security rights to create a new profile, the **New Profile** button on the toolbar will be disabled, and you cannot access the **New Profile** option from the **Insert** menu.

The examples below illustrate visual indicators displayed in Attendant for various ACL combinations. For more information about access rights, refer to the **Access Control** topic in the *Interaction Administrator Online Help*.

No Rights

A user with **no rights** to View a call flow will see a padlock icon at the root node, which cannot be expanded to reveal any details of the configuration.

.....  Rum - Inbound Call Configuration (Read Only)

View-only Rights

A user with **View-only** rights to a call flow can expand locked portions of the tree, but the user cannot make changes or export the call flow configuration.

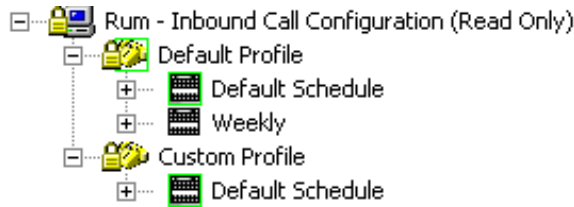

Modify Rights

A user who has the right to modify one or more Profiles can expand the call flow to view individual nodes. Profiles that the user cannot modify have a Padlock icon.

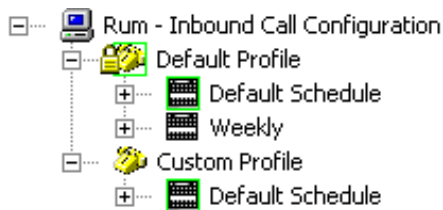

In the example above, the user can modify the Custom Profile, but not the Default Profile, since the Modify right was assigned to a single profile in Interaction Administrator. If *[All] had been selected, the right would allow access to all Profiles for that call flow type.

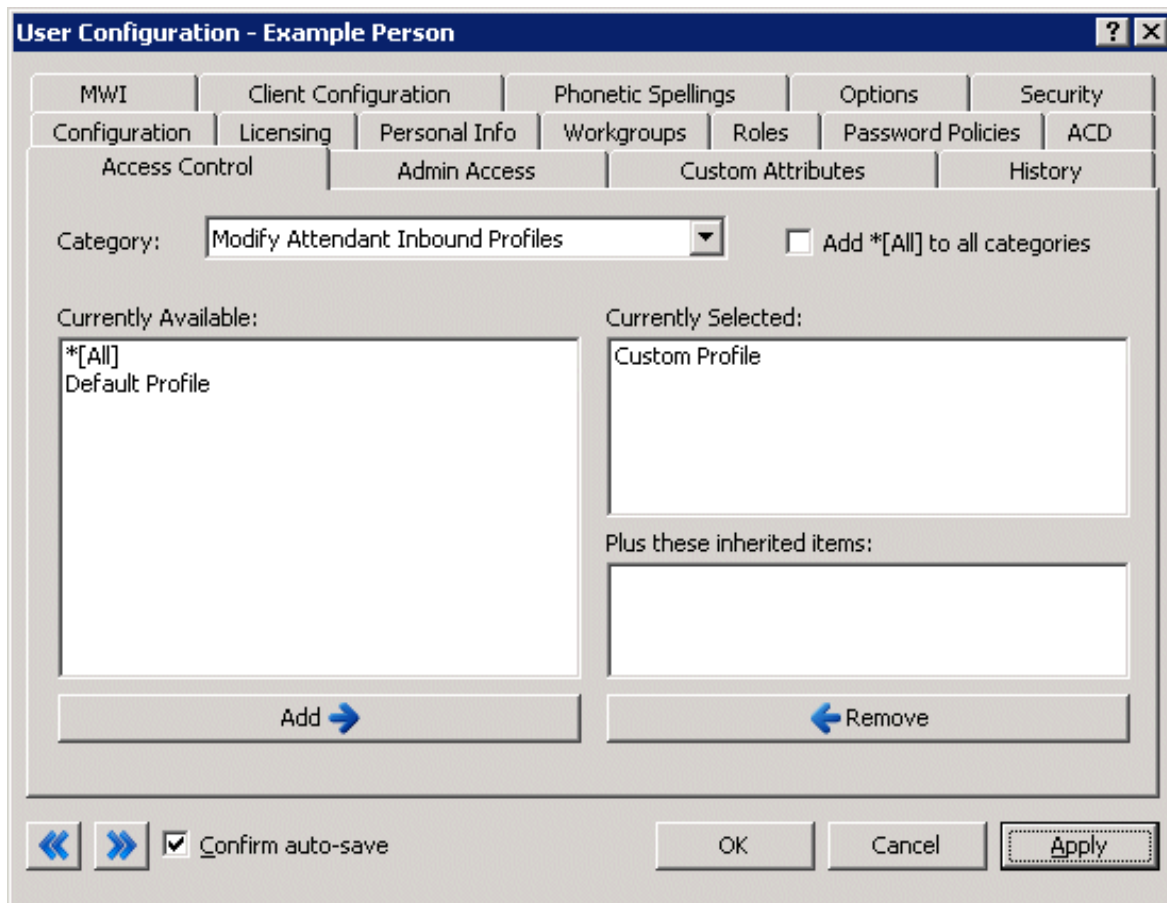

See also: [Rights required to use Attendant](#)

Start Interaction Attendant

Once you have [installed](#) Interaction Attendant, you can follow these steps to start the program:

1. Press the **Start** button.
2. Select **All Programs, PureConnect**, and then **Interaction Attendant**. After a few seconds, its splash screen will appear.

Note:

Automatic Authentication

If you are already logged in to a CIC server using Interaction Client or third party CIC application, you do not need to connect to that server manually. Attendant authenticates CIC users and will grant access automatically if your NT credentials match the needed CIC user account, or you already have a Notifier connection. When authentication succeeds, a node for the server is added at startup, and you can begin editing its configuration.

3. The default shortcut does not pass any ID and password information to Attendant. If you specified a different server name during installation, Attendant will display a "login failed" alert. Press **OK** to dismiss this message if it appears.
4. If a [Login dialog](#) appears, enter a valid CIC username and password. Then specify a configuration type (inbound, outbound, operator, or All). Press **OK**. If authentication fails, Attendant redisplay the Login dialog, so that you can correct a typing error or login using a different ID. Once you are logged in, a server node will appear in the tree.
5. After Attendant connects to a server, it attempts to load a call flow configuration into memory for editing. If the call flow configuration does not exist, it adds default profile and default schedule forms below a node for the server. This provides the default structure needed to build a menu interaction.
6. If you need to edit the configuration of another server, [connect to the server](#) now.

Optional Command-Line Parameters

You can log in to any server automatically by adding optional parameters to the shortcut used to start Interaction Attendant. Command-line switches are not case-sensitive. Just add server, ID, and password information to the shortcut:

Parameter	Abbreviation	Description
/notifier	/n	Specify the CIC Server name to connect to.
/user	/u	Specify the CIC User login name.
/password	/p	Password for CIC User's password.
/readonly	/r	Opens Attendant in Read Only mode, preventing the configuration from being changed or exported to a disk file. See Interaction Attendant Read Only Feature .
/offlineedit	/oe	Opens Attendant in Read Only with Edit mode allowing the in-memory configuration to be edited. See Interaction Attendant Read Only Feature .
/export=[filepath]	none	Export a backup configuration, where [filepath] is replaced with the location to which you want to export the backup configuration. See Export a Configuration file (entire call flow) .
/fullexport=[filepath]	none	Export a full configuration, where [filepath] is replaced with the location to which you want to export the full configuration. See Export a Configuration file (entire call flow) .

For example, if the name of your CIC server is Athena, your CIC UserID is myID, and your password is myPassword, the command line would read:

```
"C:\Program Files\Interactive Intelligence\InteractionAttendantUD.exe" /n=Athena /u=myID /p=myPassword
```

Command line arguments are separated by a space. If you prefer to use the verbose form of the command-line switches, the same command line would be:

```
"C:\Program Files\Interactive Intelligence\InteractionAttendantUD.exe" /notifier=Athena /user=myID /password=myPassword
```

Call Flow Configuration Switches

Additional startup switches determine which call flow is displayed in the tree view at startup. Switches are not case-sensitive; you can use upper or lower case.

Call Flow	Abbreviation	Description
Inbound	/in or /inbound	Display Inbound Call Flow Configuration
Outbound	/out or /outbound	Display Outbound Call Flow Configuration
Operator	/op or /operator	Display Operator Call Flow Configuration
Email	/e or /email	Display Email Call Flow Configuration For example, to open the email configuration: <code>InteractionAttendantUD.exe /n=servername /u=CICUserName /p=password /e</code>

Related Access Rights

[Call Flow Configuration Switches](#) work only if the right to view or modify Attendant call flow types (Inbound, Outbound, or Operator) is assigned to the user outside of Interaction Attendant, using Interaction Administrator. These rights may be assigned to the default user, users, workgroups, and roles. See [Rights required to use Attendant](#) for details.

Related Topics

- [Optional Command Line Parameters](#)

Modifying shortcuts

To modify the shortcut used to start Attendant, follow these steps:

1. Press the *Start* button.
2. Select *All Programs*, *PureConnect*, and then right-click *Interaction Attendant* to open its context menu.
3. Select *Properties* from the context menu.

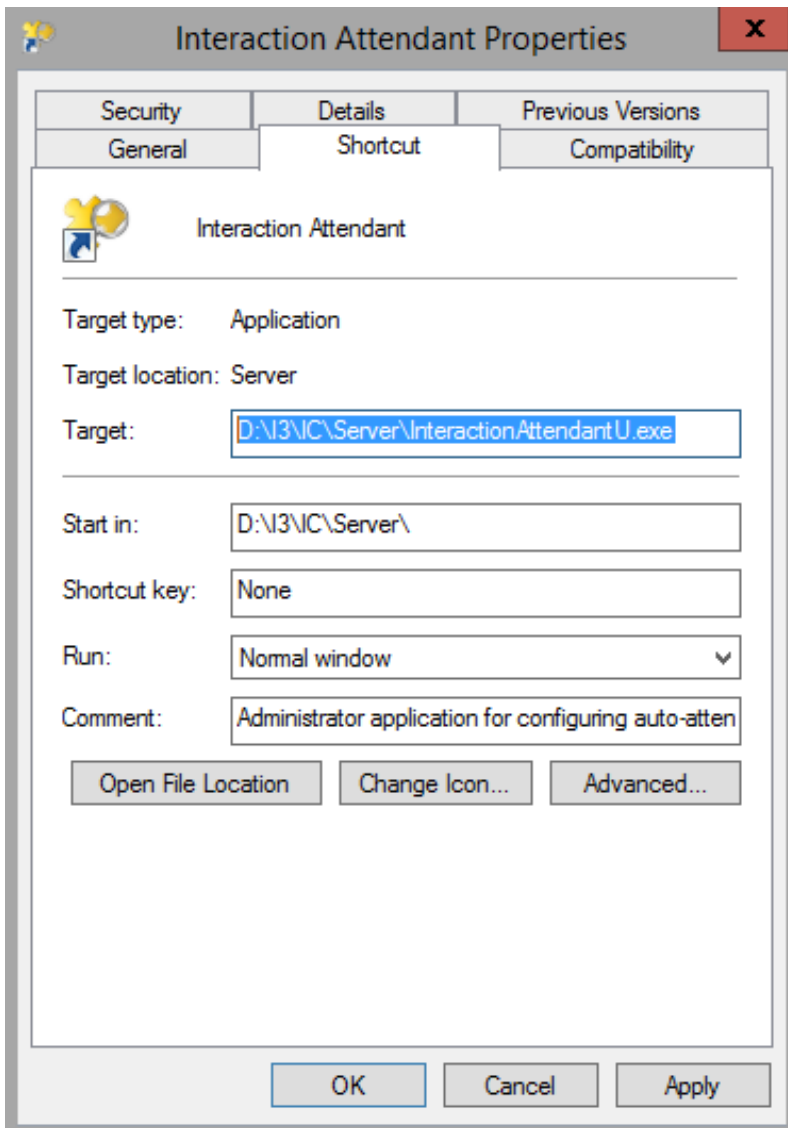

4. Modify the *Target* statement to add Notifier, user, and password arguments.
5. Press OK. The next time you start Attendant using this shortcut, it will connect to the specified server automatically.

Note—if you start Interaction Attendant without any command line parameters, you must connect to an CIC server by pulling down the File menu and selecting the Connect command.

Related Topics



- [Install Interaction Attendant](#)
- [Attendant Concepts](#)
- [Connect to a server](#)

? Access Help, Web, and System Information

The *Help* menu opens help topics and web resources. It also displays version information about Attendant and your computing environment.

Online Help

There are several ways to open online help:

1. To display help for the current node, press F1 or the Form Help button () button in the main toolbar. It opens a topic that explains the current property sheet.
2. To open the default help topic, press Shift-F1 or press the Help Contents toolbar button ().

Version and System Information

Collectively, these options provide information that may be useful in a technical support situation. However, you do not need to understand these items of data in order to use Interaction Attendant.

1. For general information about your computing environment, choose *About Attendant* from the *Help* menu.
2. Then press *CIC Info* for information about your CIC server. The version number of CIC is also the version of Interaction Attendant.

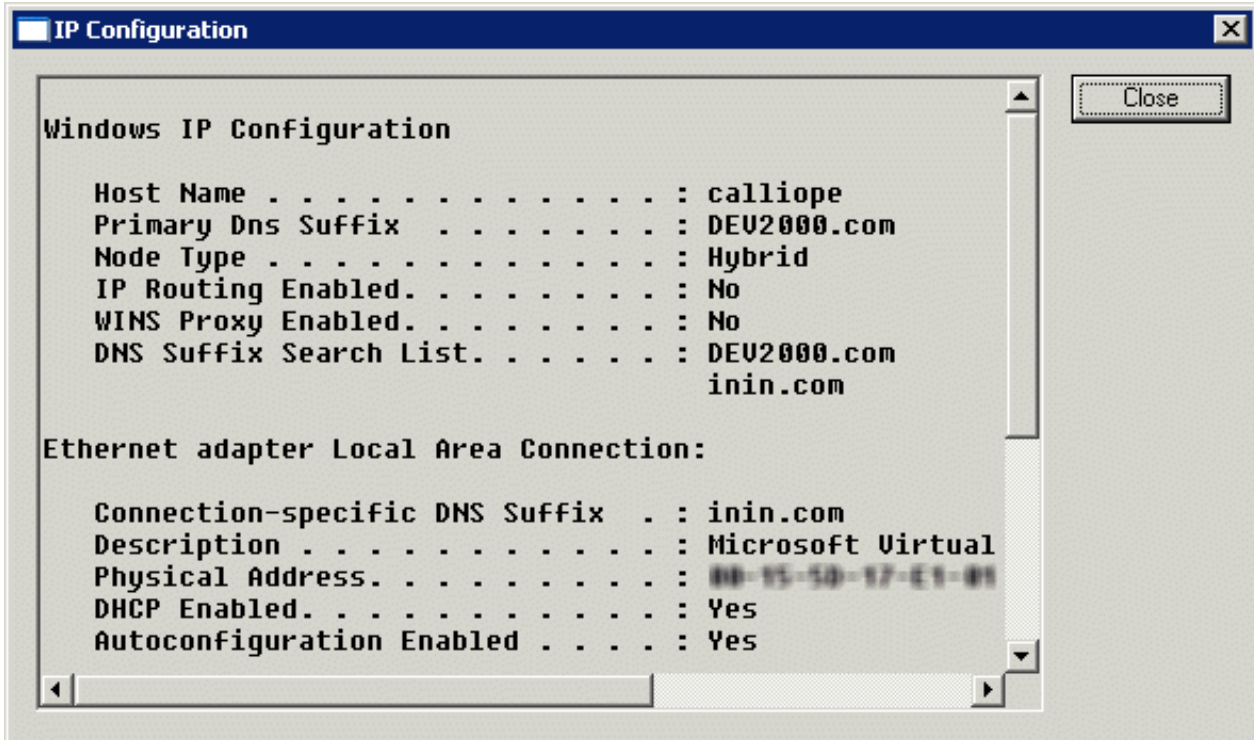

3. For information about Internet Protocol, press *IP Configuration*. When you are finished, press *Close*.
4. For information about your computer system, press the *System Info* button. This opens the *System Information* dialog shown below.

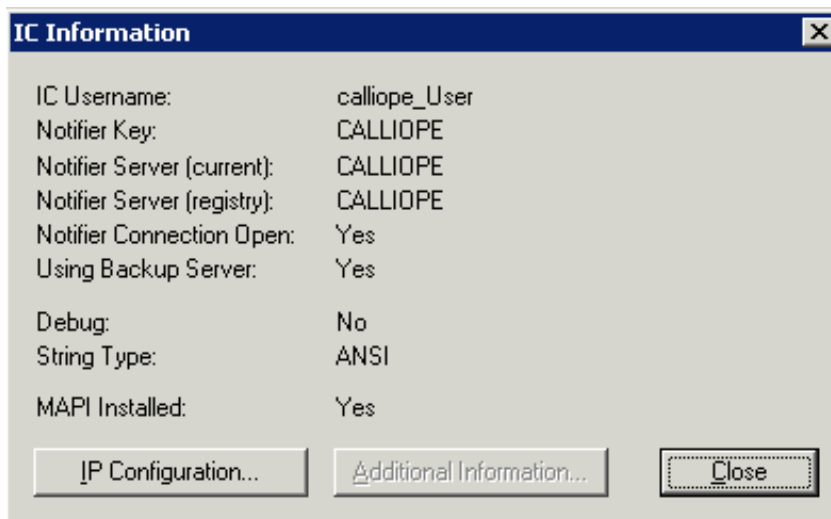
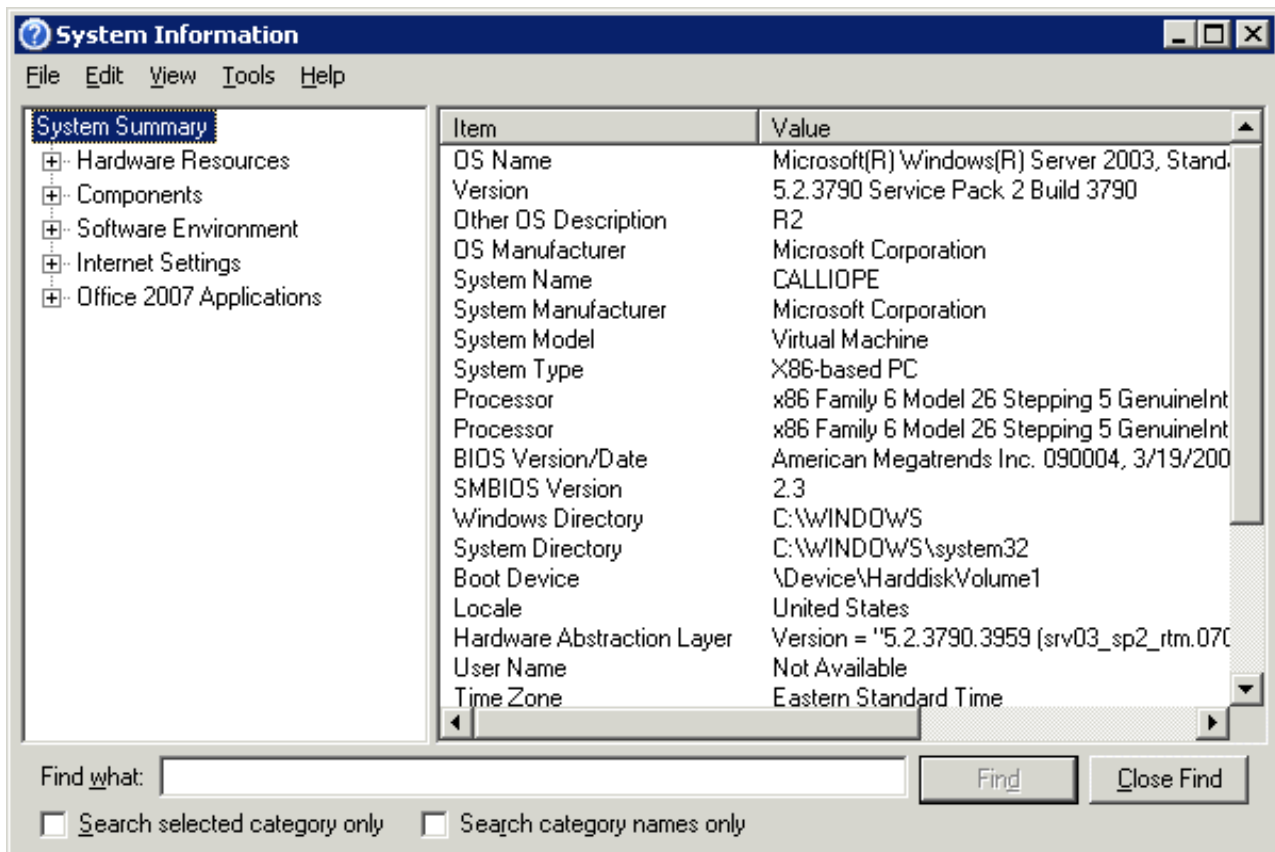

- When you are finished, dismiss the dialog by clicking *Close*.
- Press *OK* to close the *About IC* dialog.

Contact Genesys

It is easy to access Genesys online resources from this application. From the *Help* menu, select **Genesys**. Then choose one of the following:

- *Home*—opens the Genesys web site using the default web browser installed on your computer. This URL is <http://www.genesys.com/>.
- *Support*—opens the Support Services section of the Genesys web site. An ID and password is required to obtain access to support tips, files, and product updates.
- *Community*—takes you to PureConnect Community Forum, a free public forum provided by Genesys that promotes the sharing of ideas and information regarding PureConnect software. Opinions expressed on the PureConnect Community are not those of Genesys, and Genesys accepts no legal responsibility for their veracity or nature.
- *Feedback*—opens a web form that allows you to submit feedback to Genesys regarding products and enhancements that you would like to see in future products or product releases.

In many applications, this feature is also available from the *Help > About* dialog. To access it, pull down the *Help* menu and select *About*. When the *About* dialog appears, press the **Genesys** button to display the options listed above.



Connect to a Server

Attendant adds a Server node when you connect (login) to a server. The nodes that collectively configure the server appear beneath the server node. Interaction Attendant can connect to more than one CIC server at a time. This makes it easy to administer multiple servers and see them all in the tree view. If you run Interaction Attendant and the tree structure is empty, or the tree structure does not display a [server form](#) for the server that you wish to configure, you need to establish a connection between Interaction Attendant and the desired CIC server.

The *Connect* command establishes a connection. It opens Interaction Attendant's [login dialog](#) so that you can login to a server. A successful login loads that server's configuration into Interaction Attendant for editing, and adds its server node to the tree view. When you are finished, [publish the configuration](#) to put changes into effect.

Automatic Authentication

If you are already logged in to a CIC server using Interaction Client or another application, you do not need to connect to that server to access its profiles. Interaction Attendant automatically authenticates valid CIC users to grant access. If your NT credentials match the needed CIC user account, or you already have a Notifier connection established, a node for the server is added to the tree at startup.

Connect Procedure

1. Invoke the Connect command using one of the following methods:

- Pull down the *File* menu and select *Connect*.
- Pull down the *Insert* menu and select *New Server*.
- Press the  (New Server) button on the main toolbar.

- Pull down the *Edit* menu and select *Manage Servers* (or press the  *Manage Servers* toolbar button). When the [Servers](#) dialog appears, press the *Connect* button.

2. When the [Login dialog](#) appears, enter a valid CIC username and password. Select a configuration type (inbound, outbound, operator, or All). Then press *OK*. If authentication fails, Attendant redisplay the [Login dialog](#), so that you can correct a typing error or login using a different ID.

3. When authentication succeeds, Attendant checks to make sure that needed directories exist. If a new language has been defined on the server, Attendant attempts to create a folder to store prompts for that language. If for some reason it cannot create a needed folder, it displays an alert:

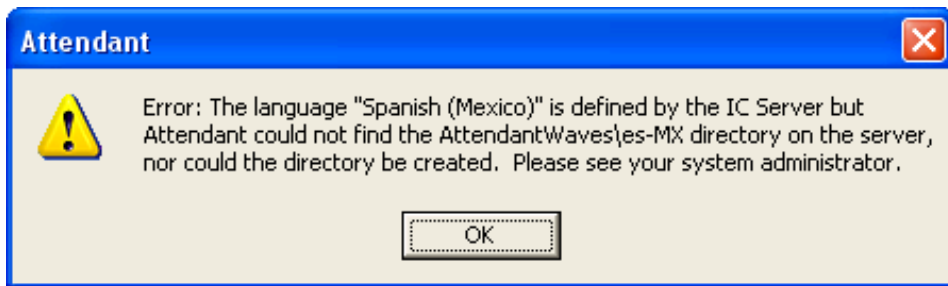

If this alert appears, ask your system administrator to create a folder on the server for the needed language. He or she needs to know the name of the directory ([locale code](#)) that appears in the alert. In the example above, the needed directory is AttendantWaves\es-MX. If the directory does not exist, Attendant will be unable to save prompts for the new language. See [where files are stored](#) for more information.

4. Next, Attendant checks to see if anyone is editing the configuration of the server that you are connecting to. If no one is making edits, Attendant adds a [node for the server](#) to the tree view and you are free to begin working with it.

However, if the server's configuration files are already open for editing, Attendant considers the configuration to be *locked*. It displays one of the following dialogs:

- The [Attendant In Use Dialog](#) will appear if another person is editing the configuration of the server. Press *OK* to dismiss this dialog. You can use Attendant to view and modify the configuration, but you will not be able to publish any changes to the server. To save your edits, you must [backup export](#) the configuration to a disk file, and [import](#) it later when no one else is editing. Since importing a configuration will overwrite all changes that the other person is making, a gentler and kinder approach might be to contact the person who is editing the configuration to find out when they will be done.
- The [Stale Lock Dialog](#) appears when the configuration of the server has been locked for more than 24 hours. This typically indicates that the user did not shut down Attendant properly. Attendant displays information about the lock, and provides the option to overwrite it. If you overwrite the lock, you can edit and publish configuration data for the server without any restrictions. If you do not overwrite the lock, Attendant will prevent you from publishing changes to the server. To save your edits, you must [backup export](#) the your configuration to a disk file, and [import](#) it later when the lock has been removed.
- The [Same User Lock](#) dialog appears if a second instance of Interaction Attendant is connecting to the server using your ID. If you are confident that no one else is running Attendant with your User ID (perhaps you started Attendant twice), you can overwrite this lock and continue safely.

However, we do not recommend that you overwrite the lock if someone else is using your ID, since Attendant will allow both of you to publish changes that could collide logically with one another.

It is safe to run more than one instance of Interaction Attendant if you connect to *different* CIC servers. If you connect multiple instances to the same server, Interaction Attendant won't stop you from saving a configuration that is open in another session. This could potentially lose changes made in another instance. That's why Attendant displays the *Same User Lock* dialog to warn you.

"Read Only" and "Read Only with Offline Editing" modes

A user can login to Interaction Attendant without locking the entire configuration. A check box on the [login dialog](#) selects Read Only mode, in which actions views are disabled, and no adding or deleting of nodes can occur. Read-only mode disables modification of actions, schedules, and profiles. In this mode, the in-memory configuration cannot be exported.

The login dialog also provides a With offline editing check box, which allows the configuration to be edited in-memory and exported for later importing. In this Read Only with Edit mode, you can use Attendant to view and modify the configuration, but you will not be able to publish any changes to the server. To save your edits, you must backup export the configuration to a disk file, and import it later when no one else is editing.

These modes may be specified when starting Attendant using [optional command line parameters](#). For background information about read-only modes, see [Interaction Attendant Read Only Feature](#).

Related Topics

- [Login Dialog](#)
- [Attendant In Use Dialog](#)
- [Stale Lock Dialog](#)
- [Same User Lock](#)
- [Server Form](#)
- [Manage Configuration Files](#)

Interaction Attendant Read Only Feature

This topic describes Read Only mode features in detail.

[Feature Overview](#)

[Selecting a Read Only mode when connecting to a server](#)

[Related Command Line Parameters](#)

[Related Toolbar and Menu Commands](#)

[Dialogs that appear when switching modes](#)

Overview

By default, when a user runs or logs into Attendant, it tries automatically to gain a lock on the entire server configuration. If no other user has a lock on the configuration, it will successfully acquire the lock. At that point, no other user can edit and publish changes while the lock is in place. The lock exists for as long as the user is connected to that server through Attendant.

This can be problematic for customers who have users that occasionally want to examine the configuration without locking it, and thereby denying others the ability to edit and publish changes. The read only feature introduced in CIC 3.0 SU12 is a solution to that problem. Using this feature, users can open Attendant in read only mode without locking the configuration.

Two slightly different read only modes are available:

- **Read Only mode** disables all actions views, preventing addition or deletion of nodes, including actions, schedules, and profiles. In this mode, the in-memory configuration cannot be exported.
- **Read Only with Edit mode** allows the configuration to be edited in-memory and exported for later importing. In this mode, users can view and modify the configuration, but not publish changes to the server. To save edits, users must export the configuration to a disk file, and import it later when no one else is editing.

Selecting a Read Only mode when connecting to a server

Checkboxes on the [Login dialog](#) optionally select read only mode with or without editing capability:

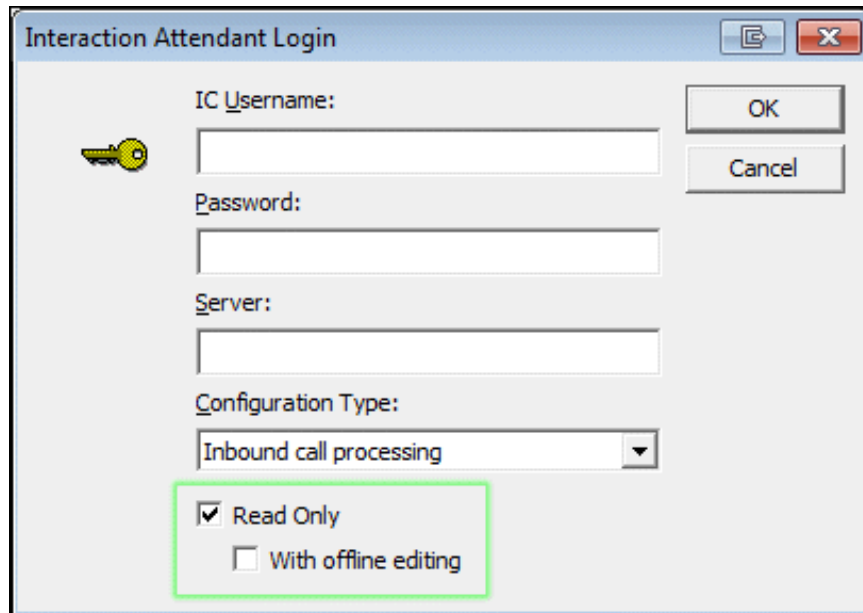

Read Only check box

Use this option to login without locking the entire configuration. It selects **Read Only** mode, disabling modification of actions, schedules, and profiles. In this mode, the in-memory configuration cannot be exported.

With offline editing check box

The additional option is disabled unless the *Read Only* check box is also checked. It allows the configuration to be edited in-memory and exported for later importing. In this **Read Only with Edit** mode, users can view and modify the configuration, but cannot publish changes to the server. To save edits, the user must export the configuration to a disk file.



Related Command Line Parameters

Read only modes can be specified when starting Attendant using [optional command line parameters](#). The command line options for specifying read only are:

- `/r` or `/readonly` connects Attendant to the server in **Read Only** mode.
- `/oe` or `/offlineedit` connects Attendant to the server in **Read Only with Edit** mode, allowing the in-memory configuration to be edited and exported to disk, potentially to be imported later.

Related Toolbar and Menu Commands

Toolbar and menu commands allow a user to switch between read only modes. These options are enabled when the server node is selected. To use these commands, the user must have selected a read only mode when connecting to the server, or when starting Attendant using command line parameters.

- The **Modify Mode** button () selects *Read Only with Edit* mode.
- The **Read Only** button () selects *Read Only* mode.

Similar selections appear in the **File** menu.

Dialogs that appear when switching modes

Several dialogs appear when switching between modes:

- In *Read Only with Edit* mode, a warning dialog appears when the user makes any change, reminding that changes cannot be published, but may be exported. That warning is displayed once, following the first edit.
- If changes are made in *Read Only with Edit* mode and the user subsequently switches to *Read Only* mode or close the application, the user is prompted to export changes to an export file.
- When a user opens Attendant using `/r` on the command line (to specify *Read Only* mode), but then switches to Modify mode when the lock is already taken, the mode is switched to *Read Only with Edit* mode. This is functionally similar to Attendant's default behavior when someone else has the configuration locked.
- The mode is managed in this way because the user could switch to modify mode with the intention to edit the configuration. Since the user cannot obtain the lock at this time since someone else has it, Attendant provides the next best thing, which is *Read Only with Edit* with the ability to export changes to a file.
- When the user switches to *Read Only* mode using the toolbar or menu option, the user is asked whether or not editing capability is desired. (i.e. offline mode).

Manage Nodes in the Tree

The following topics explain how to work with nodes in Attendant's tree.

- [Add a custom Profile](#)
- [Add a custom Schedule](#)
- [Add an Operation](#)
- [Add Dial by Name functionality to a menu](#)
- [Add Dial Extension functionality to a menu](#)
- [Add Group Transfer functionality to a menu](#)
- [Collapse Tree](#)
- [Create a Menu](#)
- [Create a submenu](#)
- [Cut, copy, and paste nodes](#)
- [Deactivate/Activate nodes in the tree](#)
- [Delete a node](#)
- [Error Resolution](#)
- [Expand Tree](#)
- [Invoke a menu operation automatically](#)
- [IVR Reporting Option](#)
- [Listen for Extension Dialing option](#)
- [Modify properties of an existing node](#)
- [Refresh Server Data](#)
- [Rename a node](#)
- [Repeat a Menu](#)
- [Show or Hide the Main Toolbar](#)
- [Show or Hide the Status bar](#)
- [Sort the Tree](#)
- The [default Auto-Attendant menu](#)
- [View the Interaction Log](#)
- [View Information about an error](#)
- [Visual Indicators in the Tree](#)



Add a custom Profile

1. To add a new profile, select a server or profile node in the tree. This enables the *New Profile* command.
2. Do one of the following:
 - Press the New Profile button () on the main toolbar.
 - Pull down the *Insert* menu and select *New Profile*.
 - Press the right mouse button while the mouse is over an object, and choose *Insert* then *New Profile* from the context menu.
3. Fill out the property sheet for the profile. See [Profiles](#) for more information.



Add a custom Schedule

1. To add a new schedule, select a profile or schedule in the tree to enable the *New Schedule* command. Schedules stipulate when a menu can run.
2. Do one of the following:
 - Press the *New Schedule* button () on the main toolbar.
 - Pull down the *Insert* menu and select *New Schedule*.
 - Press the right mouse button while the mouse is over a profile or schedule. Then choose *Insert* > *New Schedule* from the context menu.
3. Fill out the property sheet for the schedule. See [Schedules](#) for more information.

Add an Operation

Operations are actions that Interaction Attendant performs within a menu, usually in response to a user key press. To add an operation, follow these steps:

1. Select a Schedule, menu, or multi-action node in the tree.
2. Do one of the following:
 - Pull down the *Insert* menu and select *New Operation*.
 - Press the right mouse button and choose *Insert > New Operation* from the context menu.
 - Press a button on the Operations toolbar.
3. Fill out the property sheet for the operation. See [Operations](#) for more information.

Add Dial by Name functionality to a menu

Dial by Name allows callers to review a company directory and select a user extension.

1. Select a schedule node.
2. Pull down the *Insert* menu. Select *New Operation*, then *Dial by Name*.
3. *Dial by Name1* is fairly descriptive. You can leave the text in the *Name* box unchanged, or type in a different name.
4. In the *Digit* list, type or select the number that your extensions start with.
5. Ensure that the *Active* check box is checked. The *Default Action* check box should not be checked.
6. In the *Match By* box, click "Last Name" as the pattern you want to match by.
7. In the *Matching Style* box, select *use a specific number of characters* as the style you want to match by. Set the number of characters to at least 3 characters.
8. Under Filtering, select search the entire company directory.
9. When you are done, the tree structure should resemble the graphic below. The digits that you assign may differ, depending upon the configuration of your server.

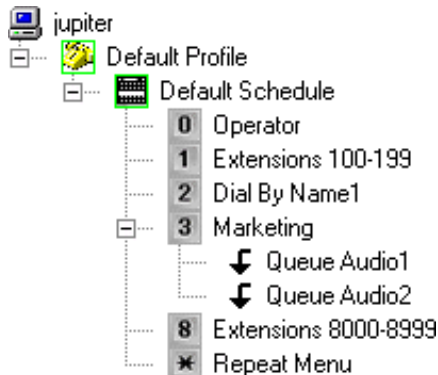

Add Dial Extension functionality to a menu

If you have extensions (user, workgroup or station) configured in Interaction Administrator, you can add nodes that allow a caller to enter an extension and be connected immediately. The digit that you assign to this operation should be the first digit of the range of extensions you want to catch. Once that digit is pressed, it is recognized as the first digit on an extension. Therefore, if your company has employees assigned to extensions 100-199 and 8000-8999, you would need to set up two extension dial nodes—one with digit 1 and one with digit 8.

For purposes of example, these instructions assume that your company has extensions assigned in the 100 to 199 range, and in the 8000 to 8999 range. Your actual extension numbers (and the digit that identifies them in a menu) may be different.

1. Select a schedule node if it is not already selected.
2. Pull down the *Insert* menu. Select *New Operation*, then *Dial Extension*.
3. Type Extensions 100-199 in the Name field.
4. In the *Digit* list, type or select the number that your extensions start with. To match our example, you would enter 1 for numbers in the 100 to 199 range, or enter 8 for numbers in the range 8000-8999.
5. Ensure that the *Active* check box is checked.
6. In the *seconds to wait (between digits) before timing out* box, type or select the number of seconds you want to wait before timing out. The default is 3 seconds, which means that user data entry will fail if the use pauses more than 3 seconds between key presses.
7. In the *File to Play to re-prompt the caller* box, select ICBadExtension.wav. This audio file will be played if the call times out.
8. In the *Number of times to re-prompt the caller* box, type or select the number of times you want to re-prompt the caller. The default value (3) is usually ok.
9. Repeat steps 1-8 to add a form for extensions in the 8000-8999 range. When you repeat step 3, name the form *Extensions 8000-8999*. When you repeat step 4, set the digit number to 8.
10. When you are done, the tree structure should resemble the graphic below. The digits that you assign may differ, depending upon the configuration of your server.

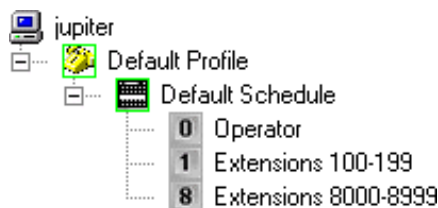

Add Group Transfer functionality to a menu

This menu option allows callers to transfer to a predefined workgroup, such as "Support" or "Marketing". It uses a Group Transfer node to transfer a caller to the workgroup queue that you specify. In this example, the name of the workgroup is "Marketing". You may substitute the name of any workgroup in your organization.

1. Select the *Default Schedule* node if it is not already selected.
2. Pull down the *Insert* menu. Select *New Operation*, and then *Transfer to a Workgroup*. A form named *Group Transfer1* appears.
3. In the *Name* field, replace *Group Transfer1* with a more descriptive name. This is the name that appears in the tree structure. It does not have to be the name of an actual workgroup in your organization. However, it is good practice to use the workgroup name in the title (e.g. "Transfer to Marketing Queue")
4. In the *Digit* list, click the number that your extensions start with.
5. Ensure that the *Active* check box is checked. The *Default Action* check box should not be checked.
6. Select the name of a workgroup from the *Workgroup* list.
7. You have the option to specify an audio prompt that will play when the call enters the workgroup. Use the embedded audio controls in the form to import, select, play, or record .wav files. In this case, we will not play an audio file when users enter the queue. Instead, we are going to add Queue Audio operations that inform the caller concerning *position in queue* and *estimated wait time*.
8. Make sure that the Group Transfer form is selected.
9. Pull down the *Insert* menu. Select *New Operation*, then *Queue Operations* and then *Play a Message to the Caller*. A new Queue Audio form will appear in the form area.
10. Ensure that the *Active* check box is checked.
11. Ensure that the *Position in queue* radio button is selected. The next step is to add another Queue Audio form, to update the caller regarding *estimated wait time*.
12. Pull down the *Insert* menu. Select *New Operation*, then *Queue Operations* and then *Play a Message to the Caller*. Another Queue Audio form will appear in the form area.
13. Ensure that the *Active* check box is checked.
14. Ensure that the *Estimated wait time* radio button is selected. When you are done, the tree structure should resemble the graphic below. The digits that you assign may differ, depending upon the configuration of your server.

Collapse Tree

This command collapses all nodes in the tree for a given server, so that only the server node is visible.

1. Select a server node or any node below the server you wish to collapse.
2. Perform one of the following actions:
 - Press the *Collapse Tree* button () on the main toolbar, or...
 - Pull down the *View* menu and select *Collapse Tree*.

Related Topics

- [Expand Tree](#)
- [Procedures](#)

Copy a node

The Copy command copies the selected [node](#) to the clipboard. You can drag and drop or cut/copy/paste nodes from one area to another in the tree. However, Interaction Attendant won't let you drag nodes from one server to another, or to paste nodes from one server to another. All node movement is restricted to the current server. Interaction Attendant also checks to see if the dropped/pasted node is assigned to a digit that is already in use by an existing node in the menu. If the new node is assigned the same digit as an already existing node, The dropped/pasted node's digit is reassigned to <None>.

Usage

This command may be invoked using any of the following methods:

- Press the *Copy* button () on the main toolbar.
- Pull down the *Edit* menu and select *Copy*.
- Press the right mouse button while the mouse is over a node, and choose *Copy* from the [context menu](#).

Related Topics

- [Cut](#)
- [Paste](#)
- [Procedures](#)

Create a Menu

Follow these general steps to create a menu interaction:

[Connect](#) to a CIC server.

Select the server in the tree.

Add a new profile by pressing the New Profile button on the main toolbar. A [profile](#) determines which menu will process an incoming call, based call selection criteria of some type. For instance, an inbound profile examines the calls [DNIS](#), [ANI](#) values, or the line or line group that the call came in on.

Set options on the profile form.

Attach a new [schedule](#) by pressing the New Schedule button on the main toolbar.

Set options on the schedule form.

Press buttons on the operations toolbar to add as many new menu operations as you like. Operations are actions that Interaction Attendant performs within a [menu](#), usually in response to a user key press. Each menu item that you add is added to the tree structure. Each menu item has its own node. To configure a menu node, select it in the tree and fill out its property sheet.

Creating a [submenu](#) is also easy. A submenu is a menu form that is attached to another menu or schedule as a child node. To create a submenu, select an existing menu in the tree before adding a new menu item. Menus are added by pressing the New Menu button in the toolbar, or by selecting New Operation | Play a Menu from the Insert menu.

Save your changes, by pressing the Publish button in the toolbar, or by selecting Publish from the File menu.

Create a submenu

Submenus are menus within menus. A submenu is a menu node that is attached to another menu as a child. A submenu is created when you select an existing menu form in the tree before adding a new menu item.

Submenus allow you to add branches to your auto attendant menus. For example, you can set up a submenu for each workgroup in your company, allowing callers to perform a variety of actions within each workgroup. Submenus also allow you to re-use the keys that are used in higher menus. For example, pressing 4 in the top level menu might allow callers to enter a Support submenu. In the Support submenu, callers might press 4 to send a fax.

To insert a submenu

In the tree structure in the left panel, select the menu in which you will add the submenu.

Press the *Menu* button in the operations toolbar to open a new Menu form. A new menu entry appears under the menu you selected in step one.

Configure the properties of the new menu item.

Cut a node

The Cut command removes the selected [node](#), and places a copy on the system clipboard. You can drag-and-drop or cut/copy/paste nodes from one area to another in the tree structure. However, Interaction Attendant won't let you drag nodes from one server to another, or to paste nodes from one server to another. All node movement is restricted to the current server.

Interaction Attendant also checks to see if the dropped/pasted node is assigned to a digit that is already in use by an existing node in the menu. If the new node is assigned the same digit as an already existing node, The dropped/pasted node's digit is reassigned to <None>.

This command may be invoked using any of the following methods:

- Press the *Cut* () button on the main toolbar.
- Pull down the *Edit* menu and select *Cut*.
- Press the right mouse button while the mouse is over a node, and choose *Cut* from the [context menu](#).

Related Topics

- [Copy](#)
- [Paste](#)
- [Procedures](#)

Deactivate/Activate nodes in the tree

If the name of a node is gray in the tree, the node's "Active" check box is unchecked. This causes Attendant to ignore the node and its children. Deactivated nodes allow you to save a configuration without making it available to callers. To reactivate the form, open the form and check the "Active" check box.

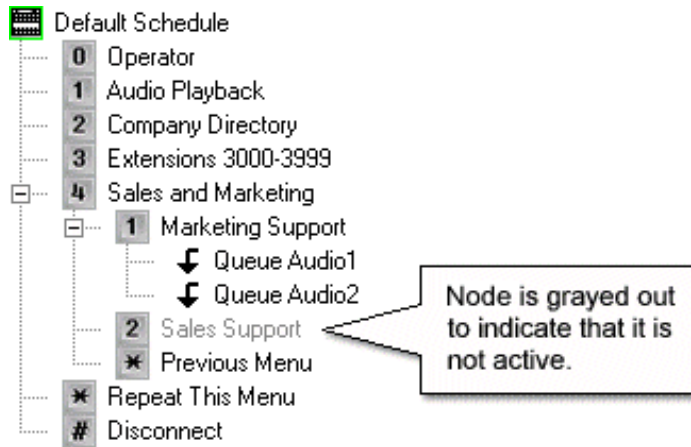

To Deactivate a node

Select the node in the tree to display its property sheet.

Locate the *Node Characteristics* frame, and uncheck the *Active* check box.

Activate a node

Select the node in the tree to display its property sheet.

Locate the *Node Characteristics* frame, and check the *Active* check box.

Delete a node

The Delete command removes a node from the tree, along with its children. You cannot undo a delete.

1. Select the node you wish to delete from the tree.
2. Press the *Delete* key. If the node has children, you are asked to confirm this operation:

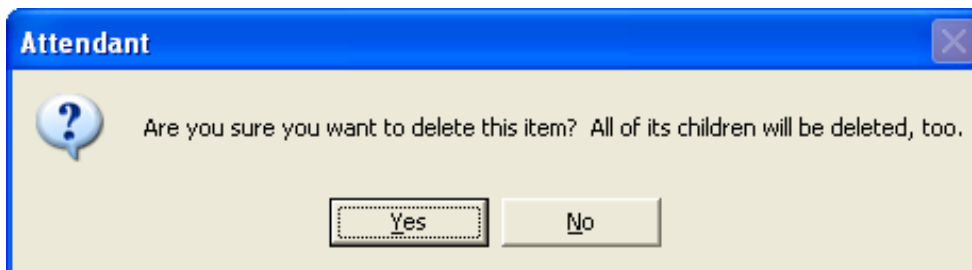

3. Press Yes to delete the node and its children. Or press No to cancel the delete operation. If the node contains child objects, they will be deleted along with the parent.

Usage

This command may be invoked using any of the following methods:

- Press the Delete () button on the main toolbar.
- Pull down the Edit menu and select Delete.
- Press the right mouse button while the mouse is over an object, and choose Delete from the [context menu](#).

Error Resolution

The error indicator will go away when you make a change that fixes all of the errors. If you fix an error, and the indicator doesn't disappear, this means that there is another error waiting to be resolved. Check the tool tip again to read an explanation of the next error.

Suppose, for example, that tool tip error text says something like "such and such a field can't be empty". If the "!" doesn't go away when you put something in the field, this just means that there was more than one error that must be resolved. Check the tool tip again for an explanation of the next error.

Interaction Attendant flags all errors that it finds. You must correct them before publishing the configuration. It won't publish a configuration that contains errors. You must fix, delete, or deactivate the offending nodes.

Related Topics

- [View information about an error](#)
- [Visual Indicators in the Tree](#)

Expand Tree

This command expands all nodes in the tree for a given server, so that you can view hidden items.

1. Select a server node or any node below the server you wish to expand.
2. Perform one of the following actions:

- Press the *Expand Tree* button () on the main toolbar, or...
- Pull down the *View* menu and select *Expand Tree*.

Related Topics

- [Collapse Tree](#)

Invoke a menu operation automatically

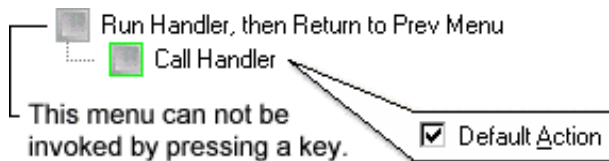

Most of the time, menu operations are invoked when callers press a key. However, a menu can execute an operation automatically *when the menu is entered*—without requiring a key press.

Here's how to create a menu that automatically invokes an operation:

1. Add a new menu.
2. Set the menu's "digit" to <None>. This prevents callers from invoking the menu by pressing a key.
3. Set the "Audio File Name" to <None>.
4. Set "Number of times to repeat this prompt" to 0.
5. Set the "Number of seconds to wait before repeating" to 0.
6. Insert a form for the operation that you want to execute when the menu is entered. Check the [default action](#) check box on the operation form (do not check this box on the menu).
7. The operation will run whenever the menu is invoked by a routing operation. For example, you might jump to this menu using a Menu Transfer operation. Whenever you set up an automatic menu operation, you must also establish a return path for control to follow once the operation has executed.

IVR Reporting Option

Options in this frame name the node, assign the digit used to select it, and establish whether or not it is active, used by default, logged, or tracked for reporting purposes.

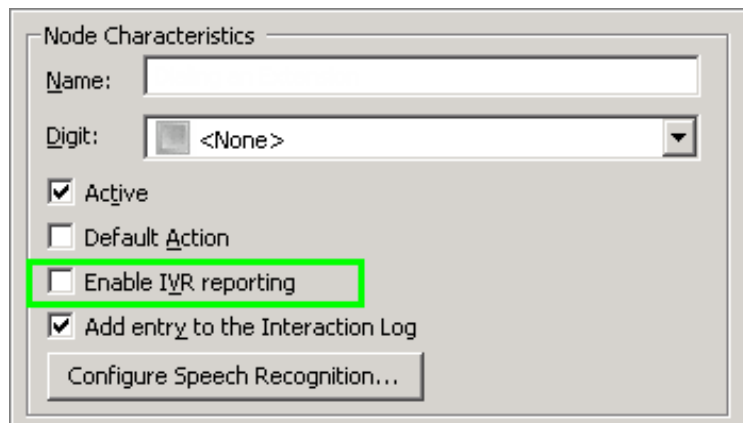

The image shows a dialog box titled "Node Characteristics". It contains the following fields and options:

- Name:** A text input field.
- Digit:** A dropdown menu currently showing "<None>".
- Active**
- Default Action**
- Enable IVR reporting** (This checkbox is highlighted with a green border in the original image.)
- Add entry to the Interaction Log**
- Configure Speech Recognition...** (A button)

Many Attendant nodes provide a check box that enables *IVR Reporting*. This option determines whether or not reporting data is collected when control passes through the node. This information is summarized in several IVR Reports. Data can be collected when Attendant profiles, schedules, menus, and complex action nodes are traversed. This feature makes it easy to establish IVR Reporting as an interaction flow is being built, without having to customize handlers and tool steps.

IVR Reporting allows customers to generate reports based on the activity of interactions through an Attendant IVR.

IVR Reporting is *disabled* by default. Check this option to enable capture of information about a node and its children for reporting purposes. The date, time and duration of time that the interaction remained in the node will be recorded. IVR Reporting allows an administrator to see how the Attendant interaction flow is being used by customers. Reports show the number of interactions that have traveled through each node, the average amount of time interactions have spent in a particular node, menu or *IVR application* (a multi-action node and its children). IVR Reports also indicate where callers disconnect. For more information, see [Run Subroutine](#) and the *Interaction Designer* help system.

IVR Reports

IVR reports summarize the activity of auto-attendant and IVR processes:

- IVR Summary
- IVR Summary by Date
- IVR Abandoned Summary
- IVR Exit Path
- IVR Breakdown
- IVR Audit

IVR Reports make it easier to monitor the effectiveness of IVR menus and prompts to determine if a desired behavior is being achieved. The end result is better IVR, ACD and auto-attendant applications. See *PureConnect Reporting Technical Reference* for comprehensive information about IVR reports.

Listen for Extension Dialing option



The *Listen for Extension Dialing* option appears on schedule and menu forms. It sets up processing that Attendant interprets to handle multiple incoming digits as extension numbers, rather than as menu selections. This option is disabled by default.

In releases prior to 2.3.1 Feature Pack 1, "Listen for Extension Dialing" enabled always treated the # key as a termination digit. Attendant has been modified to allow the # key when used by itself to work as any other menu digit and when used with other digits to work as a termination digit.

- If # is pressed by itself, Attendant handlers interpret the pound key as a menu digit.
- If # is preceded by other digits, it is interpreted as a terminator.

Listen for Extension Dialing offers advantages and disadvantages. It is a good idea to use it with discretion, since it causes user-entered digits to be processed differently, depending upon how quickly the user pressed keys. A user who is familiar with a menu may enter digits quickly, fooling Attendant into processing menu selections as an extension-dialing request. In general, you should use *Listen for Extension Dialing* only in situations that expressly call for it. Otherwise, Attendant may perform the undesired behavior of transferring calls to extension numbers that correspond to legitimate menu selections.

- If you use it, you may be able to reduce the number of extension dialing nodes in your menu interactions.
- The downside is that menu interactions are slowed down by the delay interval specified. For example, suppose that *maximum delay* is left at its default value of 2.5 seconds. A caller who enters a digit to select a menu item will wait 2.5 seconds for Attendant to process the selection.
- This feature can potentially dial an extension, when the intent of the caller is to select menu items. If a caller enters digits too rapidly, the entry will be interpreted as extension numbers to dial.

Maximum delay (seconds) for extension dialing spin control

This spin control sets the amount of time (in seconds) that Attendant shall wait for the caller to enter the next digit of an extension number. If another digit is detected within this interval, Attendant considers that digit to be part of an extension number, rather than as a menu selection. Attendant then waits the specified interval for another digit to be entered. The default interval is 2.5 seconds. *Note*—the *number of seconds to wait before repeating* value in the menu should be longer than the value set for *maximum delay (seconds) for extension dialing*.

Extension dialing takes precedence over menu option selection

When *Listen for Extension Dialing* is in effect, extension dialing takes precedence over menu option selection. This can cause unexpected processing behaviors to occur. Suppose, for example, that callers press 3 to select a menu node, and then press 1 to transfer to a Marketing queue, whose workgroup extension is 3. This works fine until *Listen for Extension Dialing* is enabled in the default schedule.

When *Listen for Extension Dialing* is enabled, any caller who presses 3 to select the menu is transferred to the Marketing queue, bypassing the menu node and any recording that it might play.

In this scenario, Attendant had to decide whether the digit entered (3) was an extension number or a menu selection. As a rule of thumb, Attendant gives extension dialing precedence over menu option selection when *Listen for Extension Dialing* is in effect. Since 3 matches the extension of a workgroup, Attendant transferred the call to that queue. To resolve this situation, you could change the Attendant menu selection digit so that it does not match an extension number.

When an extension number conflicts with a menu option, and *Listen for Extension Dialing* is active, Attendant assumes that the digit should be used to perform an extension transfer, rather than to invoke a menu selection. In a complex menu interaction, there is no good way to make extension numbers disambiguous from menu selections, so use *Listen for Extension Dialing* carefully.

Modify properties of an existing node

To modify an item in the tree, click on the [node](#) you wish to change. This displays the node's property sheet on the right side of the screen. Changes made to a property sheet do not go into effect until the configuration is [published](#).



Paste a node

Paste inserts an item from the clipboard as a child or sibling of the node that has focus. You can drag and drop or cut/copy/paste nodes from one area to another in the tree structure. However, Interaction Attendant won't let you drag nodes from one server to another, or to paste nodes from one server to another. All node movement is restricted to the current server.

Interaction Attendant also checks to see if the dropped/pasted node is assigned to a digit that is already in use by an existing node in the menu. If the new node is assigned the same digit as an already existing node, The dropped/pasted node's digit is reassigned to <None>.

Before pasting a node, Attendant checks to see if any sibling nodes with the same name exist in the destination tree. If a sibling node has the same name, Attendant prefixes the node name with "Copy of" to differentiate it from the existing node. If no nodes have the same name, the node is pasted using its original name.

Usage

This command may be invoked using any of the following methods:

- Press the *Paste* button () on the main toolbar
- Pull down the *Edit* menu and select *Paste*
- Press the right mouse button while the mouse is over an object, and choose *Paste* from the context menu

Related Topics

- [Cut](#)
- [Copy](#)



Refresh Server Data

This command polls all connected servers to retrieve information about workgroups, schedules, users, stations, skills, DB sources, lines, line groups, schedules, languages, and default language—in other words, for information that is managed outside of Attendant in Interaction Administrator.

When you connect to a server, Attendant queries it for configuration data. Refreshing data ensures that Attendant is synchronized with the configurations of connected servers. If you have been working in Attendant for an extended period of time, it is a good idea to refresh Attendant's internal snapshot of the server configuration before publishing changes.

Nothing obvious happens when you execute the Refresh Server Data command. However, Interaction Attendant uses the information received to update options presented in property sheets and dialogs. Major changes to the server configuration could invalidate a configuration, and cause [error indicators](#) to be displayed in the tree. For example, if an CIC Administrator removed a workgroup referenced in an auto-attendant menu, Attendant would flag one or more nodes in error. For this reason it is a good idea to refresh periodically, especially before publishing.

Refresh Server Data is disabled in the Edit menu unless a Server node is selected in the tree. It refreshes all connected servers, unless you refresh specific servers using the Manage Servers dialog.

1. Select a Server node in the tree.
2. Pull down the *Edit* menu and select *Refresh Server Data*.
3. Wait a few seconds for the operation to complete. Then resume your work in Attendant.

Usage

This command may be invoked using any of the following methods:

- Press the *Refresh Server Data* button () on the main toolbar.
- Pull down the *Edit* menu and select Refresh Server Data.
- Press the *Refresh* button on the [Manage Servers](#) dialog.

Rename a node

You can rename any node in the tree except default profiles, default schedules or servers. Follow these steps:

1. Select the node you want to rename in the tree.
2. Pull down the *Edit* menu and select *Rename*.
3. Type a new name.
4. Press Enter, or click the mouse button outside of the selection.

Usage

This command may be invoked using any of the following methods:

- Pull down the Edit menu and select Rename
- Press the right mouse button while the mouse is over a node in the tree structure. Then choose Rename from the context menu.
- Edit the Name of the node using its property sheet.

Repeat a Menu

It's a good idea to add an option that allows callers to repeat a menu interaction from the top. This is easily accomplished by adding a Menu Transfer form that passes control to the default schedule.

1. Select the *Default Schedule* node if it is not already selected.
2. Pull down the *Insert* menu. Select *New Operation*, and then *Transfer to a Different Menu*. Or press the  button on the main toolbar. A form named *Menu Transfer1* appears.
3. In the *Name* field, change *Menu Transfer1* to *Repeat Menu*.
4. In the *Digit* list, select the asterisk (star) key.
5. Ensure that the *Active* check box is checked. The *Default Action* check box should not be checked.
6. Select *Default Schedule* in the *Transfer the call to this menu* list. When you are done, the tree structure should resemble the graphic below. The digits that you assign may differ, depending upon the configuration of your server.

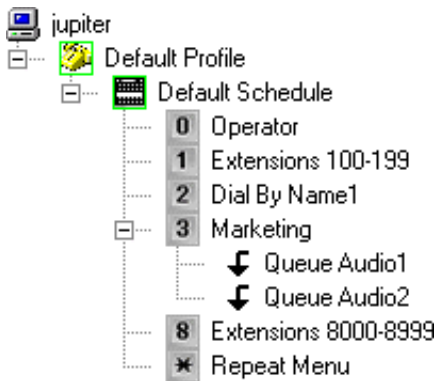

Show or Hide the Main Toolbar

Interaction Attendant provides two toolbars that issue commands quickly. The *Main* toolbar contains options equivalent to the File and Edit [pull-down menus](#). This toolbar can be hidden to recover screen space. The *Operations* toolbar adds [operations](#) to menus. It cannot be hidden.

1. The Main toolbar is displayed by default. To hide it, pull down the *View* menu and select *Toolbar*.
2. To toggle the toolbar back on, repeat step 1.

✓ Show or Hide the Status bar

Attendant displays messages in a *status bar* at the bottom of the window. Help text and informational messages appear in the status bar.

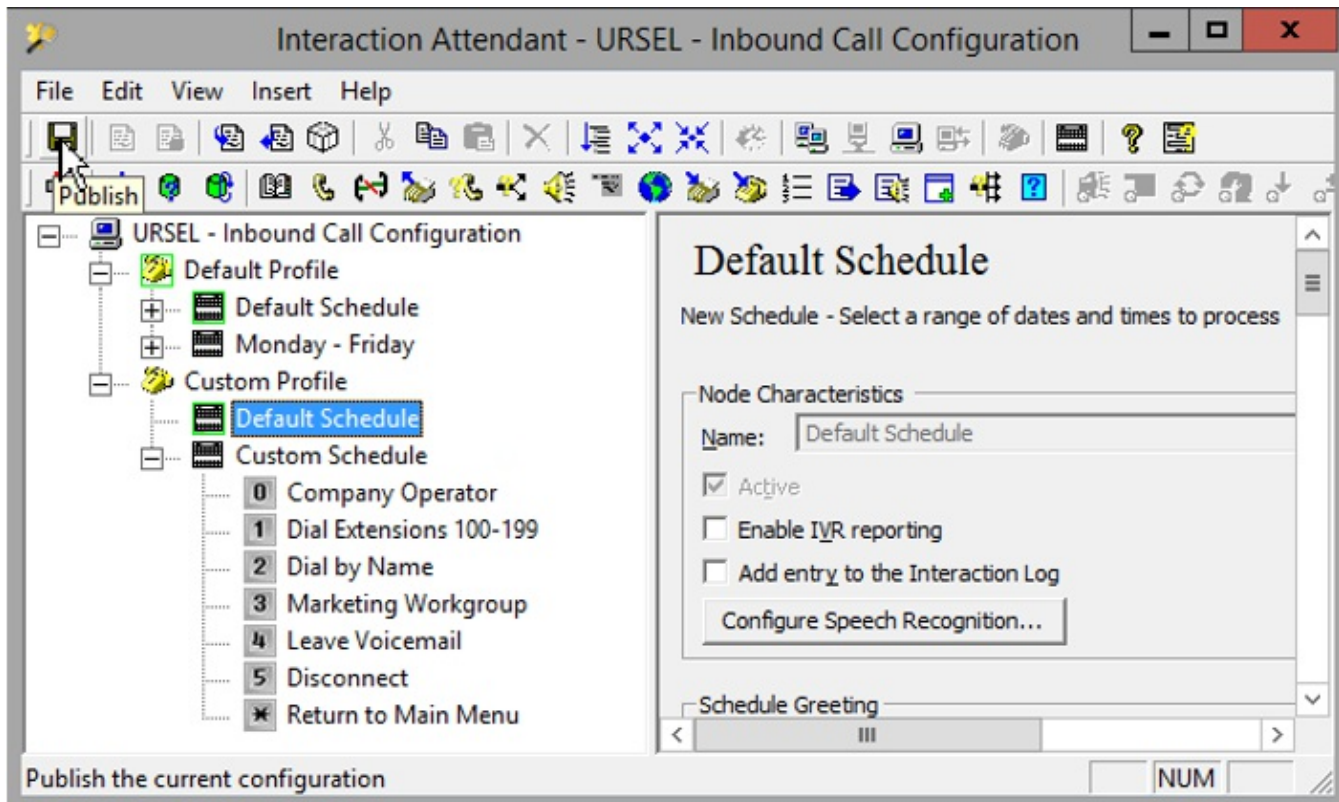

Hide the status bar

The status bar is displayed by default. You can hide it to recover screen space.

1. Pull down the *View* menu and select *Status Bar*.
2. To redisplay the status bar, repeat step 1.

View information about a toolbar command

1. Display the status bar, if it is not already visible.
2. Position the mouse over the toolbar command that you want to learn about. A description of the command will appear in the status bar.

Sort the Tree

This command reorders items in the tree structure according to precedence. Schedules and menu options are sorted based on the time in which they are active. This provides a better indication of the logical flow of control that occurs. Since the sort order is time-based, rather than alphabetic, this provides a better indication of the logical flow of control that will occur.

The figure below shows a sorted list of schedules. The default schedule is evaluated first, followed by the daily, weekly, monthly, yearly, and unplanned schedules. If two or more forms of the same type are attached to a node (for example, two unplanned schedules), those items are listed in alphabetical order within precedence.

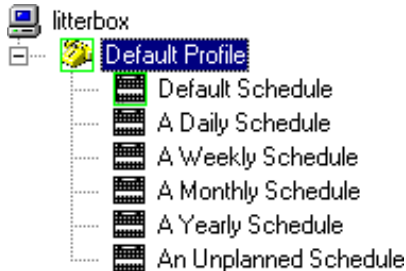

Usage

This command may be invoked using either of the following methods:

- Press the Sort Tree () button on the main toolbar.
- Pull down the *Edit* menu and select *Sort Tree*.

The Default Auto-Attendant Menu

This topic explains functionality provided by the default inbound configuration. This configuration is created by the install, unless you are upgrading and a previous configuration was found. The default configuration will match the configuration discussed in this topic, with the exception that Setup Assistant may have added an additional custom schedule for your hours of operation. It may also have customized workgroup transfers for your organization, depending upon options selected when the server was set up.

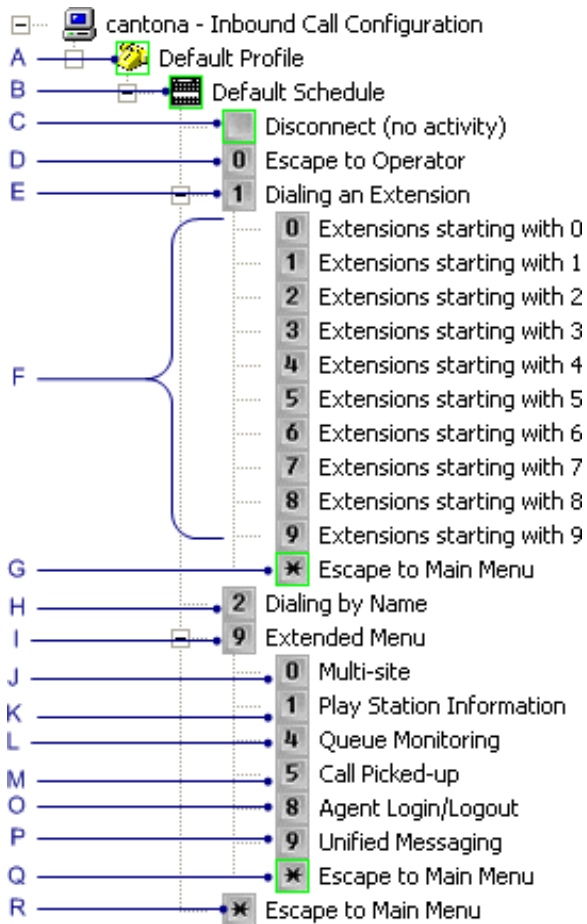

Explanation of Default Nodes

A	The Default Inbound Call Profile plays ICMMainGreeting.wav, which is a "Thank you for calling" wave file.
B	When control passes to the Default Inbound Call Schedule , it plays ICMainMenu.wav, which says, "If you know your party's extension, press 1. To dial by name, press 2. For an operator, press 0. To return to this menu at any time during your call, press the star key."
C	The <i>Disconnect</i> node plays a wave file (ICDisconnect.wav) and then disconnects if the caller does not enter digits in response to voice prompts. The wave file says, "thank you for calling...goodbye".
D	If callers press 0, an Attendant Transfer operation transfers the call to the Operator profile that matches this call.
E-F	If callers press 1 to <i>Dial an Extension</i> , a menu node plays a wave file (ICEnterExtension.wav) that says, "Please enter the extension for the party you would like to call. To return to the previous menu, press the star key". Subsequent digits are processed by Dial Extension nodes attached to the Dial an Extension menu. These nodes search the company directory to match extension numbers entered by the caller. When a match is found, the call is transferred to the specific extension.
G	If callers press *, a Menu Transfer returns control to the schedule. This is the default action if a caller does not make a selection in the <i>Dial an Extension</i> menu.
H	When callers press 2, a Dial by Name node prompts callers to enter the first three characters of a last name. The company directory is searched to find matching agents. When a match is found, the call is transferred to the agent's extension.
I	When callers dial 9, control is passed to a second-level menu node. The options in this extended menu are:
J	<i>Multi-Site</i> allows the caller to pickup an inbound multi-site call.
K	<i>Play Station Information</i> uses a subroutine initiator to invoke the PlayStationInformation handler.
L	<i>Queue Monitoring</i> uses another subroutine initiator to invoke the SystemIVRChooseQueue handler.
M	<i>Call Picked Up</i> allows the caller to pickup a call that is waiting in a queue—the call may be held, parked, or alerting. The user must have modify rights to the queue that contains the call.
O	Agent Login/Logout allows an agent to login or logout from a station phone.
P	Unified Messaging allows the caller to access voice and Email messages.
Q	A Menu Transfer node attached to the extended menu passes control back to the schedule when the star key is pressed.
R	The next Menu Transfer node is attached to the schedule. It allows callers to repeat the main menu when the star key is pressed.

Related Topics

- [Options Configured by Setup Assistant](#)
- [Manage Nodes in the Tree](#)

Options Configured by Setup Assistant

Some [default auto-attendant menu](#) options can be configured when the CIC server is installed, using a program called Setup Assistant. To use Attendant, you do not need to understand how Setup Assistant works, or how the CIC server was configured. However, two dialogs in Setup Assistant potentially modify the default inbound call flow.

Default Hours of Operation

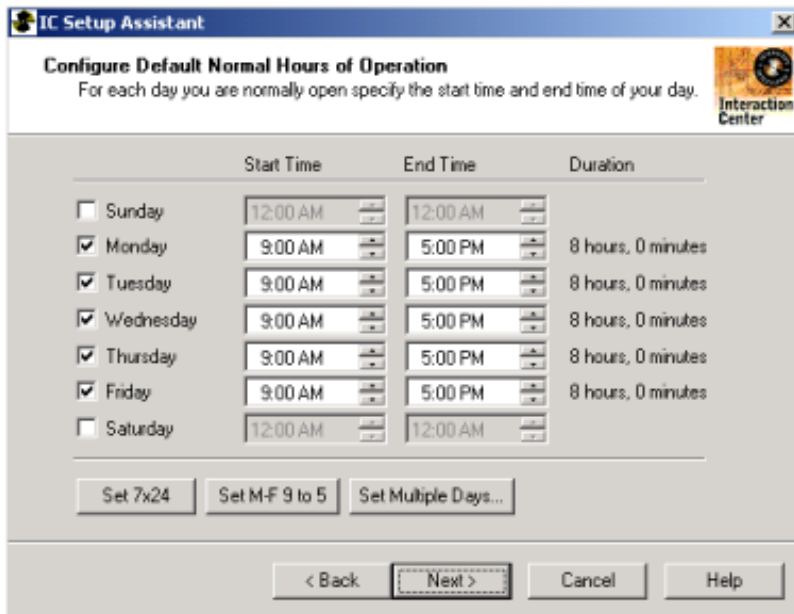

Setup Assistant displays this dialog to collect information about your company's normal hours of operation. The information provided is used to add a Custom Inbound Call Schedule node to the inbound call flow.

Group Call Processing

Setup Assistant uses another screen to configure a list of menu items associated with workgroups defined earlier within the wizard. For each menu item, a digit, workgroup, and optional overflow queue is specified. The figure below shows the wizard page and related dialogs that configure workgroup transfers in Setup Assistant.

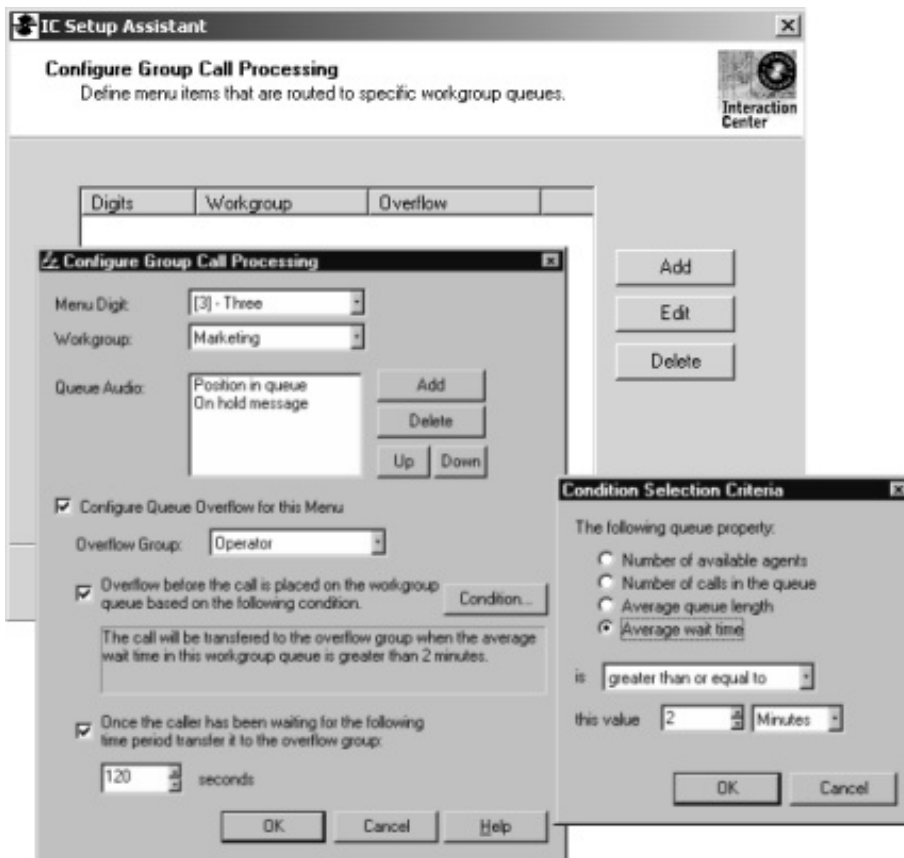

Setup Assistant uses this information to define menu options that route calls to specific workgroup queues. The resulting workgroup transfers are added to the default inbound menu.

Related Topics

- [Default Auto-Attendant Menu](#)

View the Interaction Log

When a user checks "Add entry to the Interaction Log" in an Attendant profile, information about the node is appended to the call's *Interaction Log* when the interaction enters the node. The Interaction Log contains a record of nodes traversed in Attendant, along with messages from other CIC systems that process the Interaction. The Interaction Log provides an audit trail of call processing throughout CIC.

When this option is enabled, a line of text is written to the Interaction Log each time the interaction passes through that node or one its descendants. The message logs the name of the node and the node type. For example, when an Attendant node is traversed, Attendant appends an entry to the Interaction Log to denote the event. The format of the log entry is:

User-defined Node name (Attendant Form Name)

For example, if you create a Workgroup Transfer form and name it "Transfer to Marketing", the corresponding Interaction Log entry would be:

Transfer to Marketing (Workgroup Transfer)

Using Interaction Client to view the Interaction Log

Agents can open the Interaction Log in Interaction Client to reveal the path that the call (or Email) took through Attendant. In many cases, this helps the agent to discern what the caller is looking for without having to ask the caller questions. Follow these steps:

1. Activate Interaction Connect.
 - If the call is in progress, select *My Interactions* tab. Select an interaction and select *Interaction Properties*, *Interaction Log*, or *Interaction Notes* from the sidebar control.
 - If the call has completed, select the *Call History* tab and select the *Properties* button. To select which interaction properties to display, click *Notes* or *Log*.

The Log tab describes changes in the interaction's state. This information is stored in a log file for reporting purposes.

For more information about viewing and editing interaction properties, refer the Interaction Connect help.

View information about an error

If you hover the mouse cursor over a node that has an error indicator, Interaction Attendant will display a tool tip that describes the error condition.

1. Position the mouse over a node in the tree that is flagged with an error indicator (red exclamation point, or blue down arrow).
2. Wait for a description of the error to appear as a tool tip:

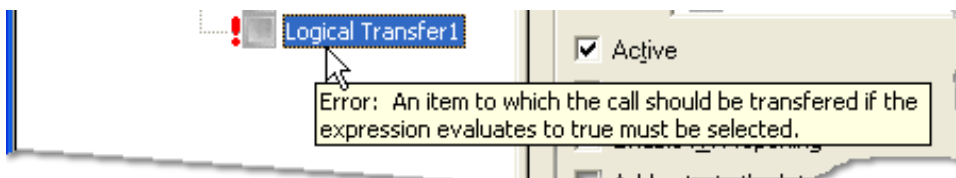

Related Topics

- [Visual Indicators in the Tree](#)
- [Manage Nodes in the Tree](#)

Visual Indicators in the Tree

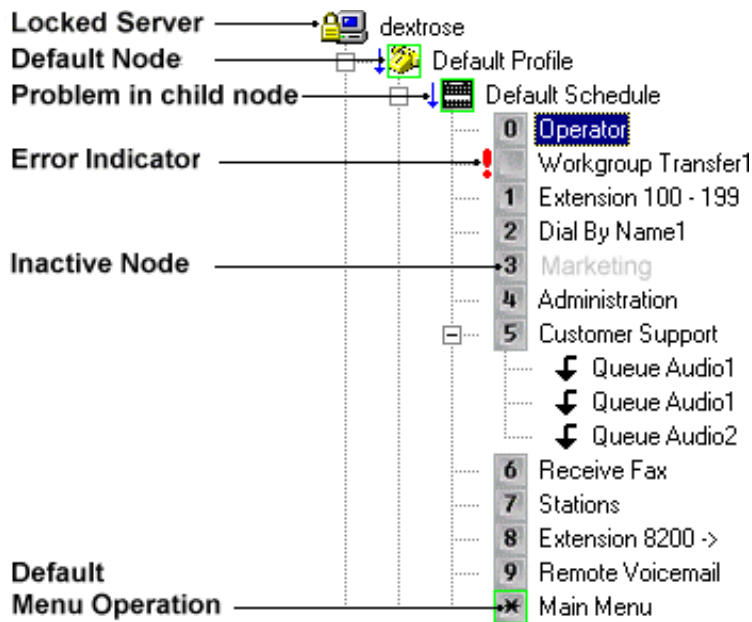

Interaction Attendant adds visual indicators to the tree to call attention to error conditions, default nodes and disabled operations.

 A padlock icon indicates that someone else is updating the server, or that the user has read-only rights to the call flow. When

 Attendant draws a **green border** around default nodes. At any level in the tree structure, one node can be marked as the *default action* to perform if the caller does not press a key within the timeout specified by that menu. To configure a node as the default action, check the *Default Action* check box in its property sheet.

Default profiles and schedules are always green, since they receive control when custom profiles and schedules do not match the call.

 A **red exclamation point** indicates that Attendant has found something wrong with a configuration setting. This usually indicates that a field was left empty, or that a selection was not made from a list box.

When you leave a node, Interaction Attendant validates it to catch problems. If a problem is found, it places a red exclamation point (!) to indicate that you need to update its property sheet. See error resolution.

 **Blue down arrows** indicate that an error exists in a child node. This helps locate problems in nodes whose red exclamation point is hidden because a parent node is collapsed. In very rare cases, the blue down arrow may be drawn incorrectly or appears partially drawn. This problem is caused by display drivers on the local computer, and does not indicate a fault in Interaction Attendant.

 **Gray text** indicates that a node is inactive. By default, nodes are "on", or "active", which means that Interaction Attendant will process them. If you uncheck a node's *Active* check box, the node turns gray to indicate that Attendant will ignore the node and its children. Inactive nodes are invisible to callers.

Manage Voice Prompts

This section explains how to manage voice prompts in Interaction Attendant.

Note:

A prompt is an audio message that informs the caller that an action is required or that a process is complete. In Interaction Attendant, prompts are wave audio files that Attendant plays to guide callers through an interaction of some sort. For example, Attendant can play a prompt when control is passed to a menu, or when a call is transferred to a workgroup. In general, prompts tell callers what to do.

Prompts are recorded using your telephone. Interaction Attendant does not use your PC's sound card to record prompts. However, it does use your sound card and speakers to play prompts when you are working in Attendant.

There are two ways to record voice prompts in Interaction Attendant. You can record prompts using [audio controls embedded in forms](#), or you can use the [Prompt Management dialog](#). The latter displays information about a selected prompt, such as which languages it has been recorded in. This makes it easy to manage prompts at a high level without having to open forms.

Note:**Prompt Format**

Customers who use Interaction Attendant may choose to have their prompts recorded by a third party and need to know our native prompt format, which is: CCITT u-law, 8kHz, 8 bit, Mono for best results.

Attendant makes it easy to offer prompts in multiple languages. To do this, you need to understand the difference between *available* languages, the *default* language, and the *current* language:

Available Languages

Interaction Attendant lists the names of *available languages* in audio-related forms and dialogs, so that you can record or play back a prompt in a particular language. The names of supported languages (e.g. English, Spanish, etc.) are defined outside of Interaction Attendant, using Interaction Administrator. If you need to record prompts in a language that Interaction Attendant does not support, you can [configure CIC to support additional languages](#).

When an additional language is defined, CIC creates a folder on the server to store prompts for that language. Since voice prompts are stored in language-specific directories, the same filename is used to refer to a prompt, regardless of the language it is recorded in. For example, you might record `greeting.wav` in English, Spanish, and French. The same name is used to refer to all versions of the file. For more information about language folders, read [where files are stored](#). Attendant makes it easy to record a prompt in different languages, using a simple set of [audio controls](#).

Default language

When you record a new prompt, Attendant assumes that you are recording in the *default language* defined for the server. The default language is defined outside of Interaction Attendant, using Interaction Administrator (on the Languages page of the **System Configuration** container). CIC supports multiple languages, but one language is configured to be used by default. Callers hear prompts in the default language unless you configure Attendant to change the *current language*.

Current Language

The language used to play prompts at runtime is known as the *current language*. The current language tells Attendant which directory to play a prompt from. You can control the language that Attendant uses in several ways:

- By specifying a specific language in a *profile* form. Profile forms filter incoming calls by examining a range of incoming call characteristics. For example, you can create a profile that plays voice prompts in Spanish when a specific number is called (DNIS), or when preferred Spanish-speaking customers call from known telephone numbers (ANI). Profiles make it easy to select a language based upon the line, line group, or number that was dialed (DNIS) or by examining the telephone number that was called (ANI).
- By allowing callers to choose the language used to play back prompts. You can use [Language Selection](#) operations to create menus that prompt callers to select a preferred language. This allows callers to dynamically choose the language used to play back prompts in other menus.

When you configure an IVR interaction in Attendant, you can preset the current language or allow callers to choose a preferred language. The current language is also evaluated when text is converted to speech.

For example, suppose that a caller's preferred language is Spanish based upon a profile form or based upon the caller's language selection. Attendant plays `greeting.wav` from the Spanish language directory on the server. When Attendant needs to play the same prompt to an English-speaking caller, it plays the file found in its English language directory.

Where files are stored on the server

Voice prompt files that you record (or import) in Attendant are saved as wave audio (.wav) files on the CIC server when a configuration is [published](#). The table below shows the physical paths and share names:

Physical Path	Share Path
<code>\I3\IC\Resources\InteractionAttendantWaves</code>	<code>\\server\AttendantWaves</code>

Default Language folder

Wave files are stored in language-specific folders below the `AttendantWaves` share. Prompts can be recorded in any language that is defined on the CIC server. When CIC is configured, one language is identified as the *default language*. Handlers play prompts in the default language when a language attribute is unspecified or is unknown. The folder that contains wave files recorded in the default language is called the default language folder.

Locale Codes

Languages come in various dialects. Attendant stores prompts for each language in a folder that it names using a locale code. Locale codes are just abbreviations that the system uses internally to identify a dialect. For example, the locale code for United States English is `en-US`. Accordingly, Attendant stores prompts for that dialect in `\i3\IC\Resources\InteractionAttendantWaves\en-US`, which is shared as `\\server\AttendantWaves\en-US`.

Alternate Language folders

Attendant creates language folders automatically—you don't have to create folders or worry about folder names. When Attendant reads the list of supported languages from the CIC server, it checks to make sure that all needed language subfolders exist. If a needed directory does not exist, it creates needed directories automatically. If it is unable to do so, it displays an error message that you should report to your system administrator—see [connect to a server](#) for details.

Language Codes

To record prompts in Attendant, you only need to understand that prompts are stored in different folders for each supported language. Here's some additional information for those who want to know more: the CIC uses language codes to name language folders. Language codes have two parts: a country part and a language part, since people in different countries sometimes speak different dialects of a language. For example, the language folder for United States English prompts is `en-us`. A folder for the German language spoken in Germany is `de-de`. Attendant's user interface automatically converts language codes to friendly names (e.g.: U.S. English) so that you don't have to care about language codes. All nodes with audio controls display the friendly audio names on all their menus and drop-down buttons. But if you browse directories on the server, you will see folders named using language codes.

Remote access to wave files on the server

Remote users who start Interaction Attendant may encounter a message similar to:

```
Error: The language "English (United States)" is defined by the CIC server but Attendant could not find the "AttendantWaves\en-US" directory on the server, nor could the directory be created.
```

If Interaction Attendant is started on the server (via the console, or Terminal Server), this message does not appear. This behavior affects remote users only, and is related to the Operating System, not to Attendant. By default, a remote user does not have access to the `AttendantWaves` directory on the server, since it is not shared by default.

As a work around, remote users can set up a mapped drive that points to the CIC server. The mapped drive does not necessarily have to point to the `AttendantWaves` directory. Mapping makes the local PC and the remote server aware of each other, so that the share reference can be resolved by Attendant.

Related Topics

- [Manage Voice Prompts](#)

Using Embedded Audio Controls

Many property pages in Interaction Attendant contain *embedded audio controls*. These controls record new prompts, or select a previously recorded prompt to play in an interaction. Use audio controls to import, select, record, or play wave audio files in any needed language. These controls make Attendant easier to use, since frequently used features are implemented consistently throughout the program.

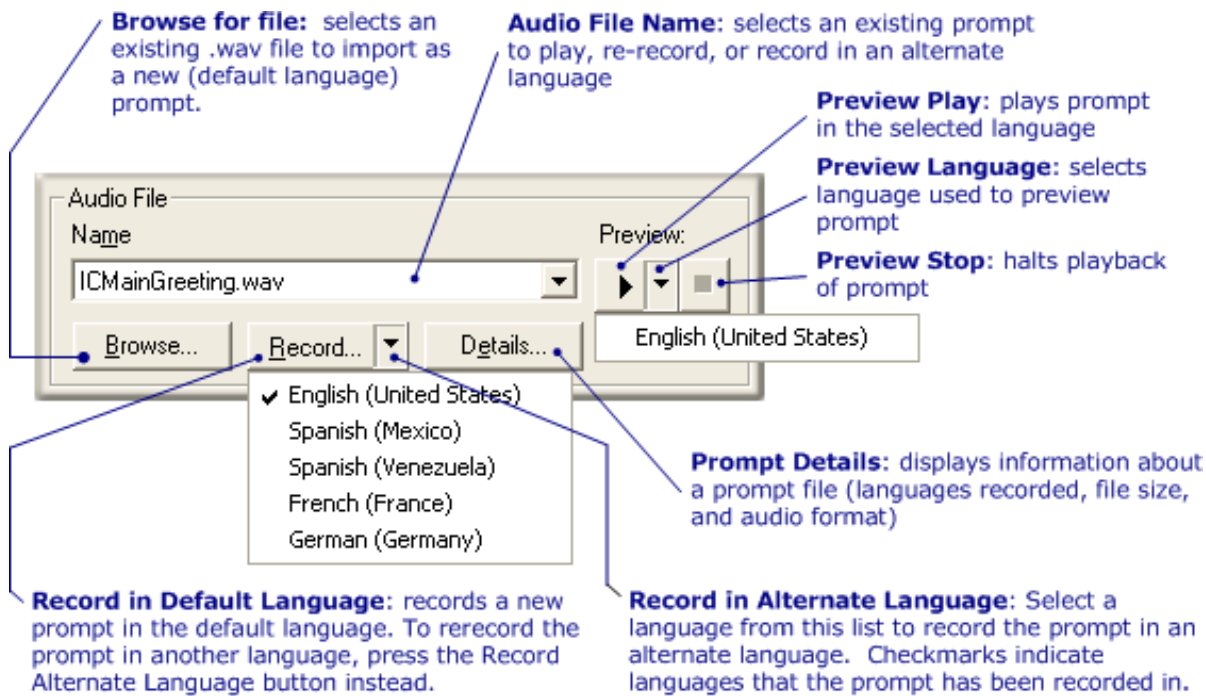

The procedures that follow this topic provide step-by-step instructions for managing prompt files.

Audio File Name list box

Selects an existing recording by name. This drop down is populated with audio files from both the "Language-locale" folder and the "Language" folder. See *Record in Alternate Language list box* below.

Preview Play button

Plays the selected prompt in the language selected using the *Preview Language* list box. This does not assign the language used to play the prompt in an interaction. The language used to play back a prompt at runtime is controlled by the *current language* setting, set by a profile form (based upon incoming call characteristics) or by a user who has interacted with a [language selection](#) node in a menu.

Preview Language list box

This drop-down lists the names of languages that the prompt has been recorded in, which is not necessarily the complete list of languages that are supported by the server. When you select a language, the prompt is played using your PC's sound card.

Preview Stop button

Halts playback immediately.

Browse button

This button opens a standard File Open dialog, so that you can select a wave file to import as the default language prompt. You can select files from any drive or server that is available to you. When you [publish](#) the configuration, the imported wave file is copied to a language-specific directory below the AttendantWaves share on the server. See [where files are stored on the server](#).

All files that you import using the *Browse* feature are assumed to have been recorded in the CIC server's [default language](#). There is currently no way to import files that were recorded in alternate languages.

Record in Default Language button

Press this button to record a new wave file, using your telephone handset. When prompted to enter a name for the new prompt, type a descriptive name in the *Name* field and then press *OK*. If you enter the name of an existing prompt, it will be replaced by your new recording.

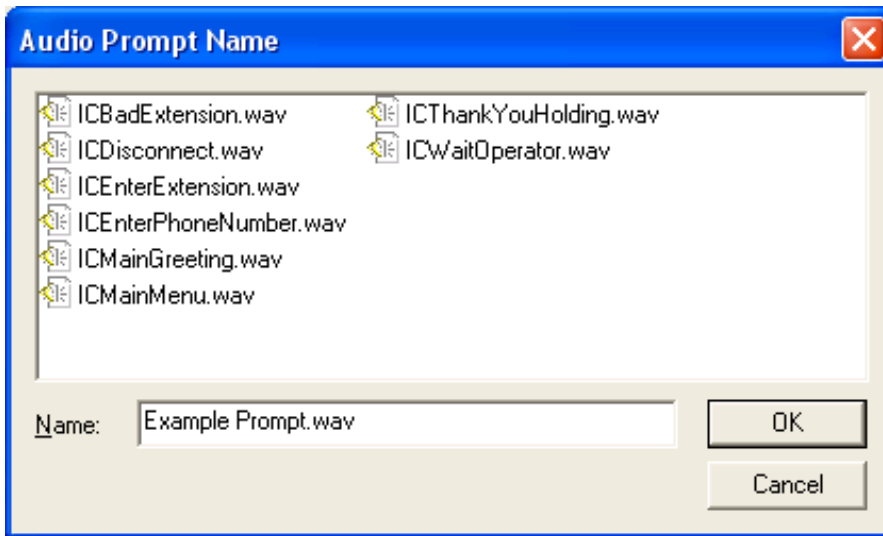

When you create a new recording, Attendant requires you to record in the [default language](#). Later, when you record the prompt in another language, Attendant uses the same filename to save another version of the file in a language-specific directory. All versions of each prompt use the filename established when the [default language](#) version was created.

Prompts in Attendant are always recorded using a telephone handset. You cannot record messages using a microphone plugged into your sound card. If you are running Interaction Client remotely, or use a SIP phone, your telephone will ring. When it does, pick up the receiver and begin speaking the prompt. When you are finished, press 1 to save the prompt.

If you are not using SIP or a remote connection, you are prompted by a dialog to pick up your telephone handset. Press *OK* once your phone is off hook. Then record the new prompt in accordance with the audio instructions that you hear.

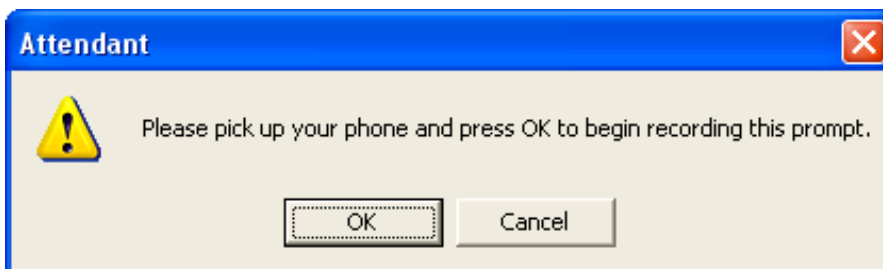

Record always creates a new prompt file. To record a prompt in another language, use the *Record in Alternate Language* feature.

Record in Alternate Language list box

Select a language in this drop-down list to re-record the selected prompt in that language. The procedure is similar to recording a new prompt, except that you are not prompted to enter a file name. See [where files are stored](#) for information about storage of prompt files in language-specific directories on the server.

Interaction Attendant creates language folders using the language code and dialect. For example, the folder for English language, United States dialect would be us-en. However, not all languages have dialects, and in other cases it is desirable to aggregate all dialects for a language. For this reason, Attendant also supports folders named after the language code only. In CIC 3.0 SU1 and later, some default prompts are stored in folders that do not named using dialect.

Attendant looks for "language-dialect" folders first, and then for a folder named after the language only. For example, if the language attribute of a call is es-AR for Spanish language, Argentina dialect, Attendant looks in the \\3\IC\Resources\AttendantWaveFiles\es-AR folder first, and then looks for \\3\IC\Resources\AttendantWaveFiles\es. Since it is possible for both to exist, you may see a selection for the language (e.g. Spanish) in this drop list, and another selection that contains both language and dialect, such as Spanish (Argentina).

Prompt Details button

This button opens the *Audio File Details* dialog, which displays the language, playback duration, and encoding format of the wave audio files for the selected prompt. If the Details button is disabled, you can enable it by choosing a prompt file from the *Name* combo box.

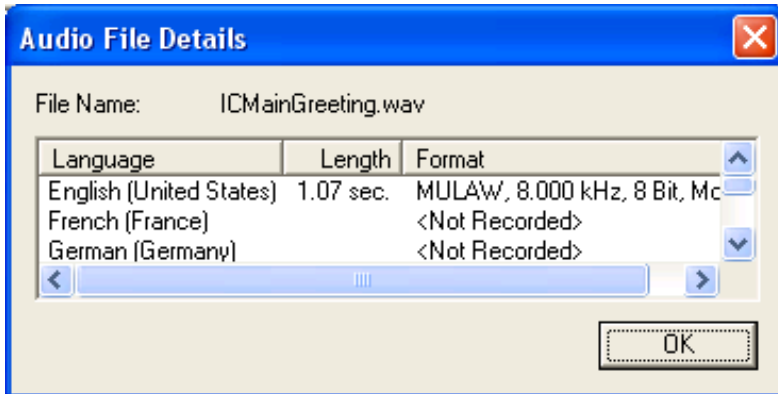

The Audio File Details dialog.

Related Topics

- [Manage Voice Prompts](#)

Record a new prompt in the default language

This procedure explains how to record a new prompt in the default language. You can perform this procedure from any form or dialog that contains [embedded audio controls](#).

1. Press *Record* to create a new wave audio file.

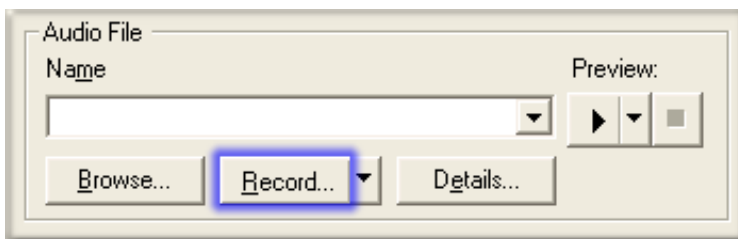

2. When the *Audio Prompt Name* dialog appears, type a descriptive name (without path information). Attendant adds ".wav" to the filename, if you do not supply the extension.

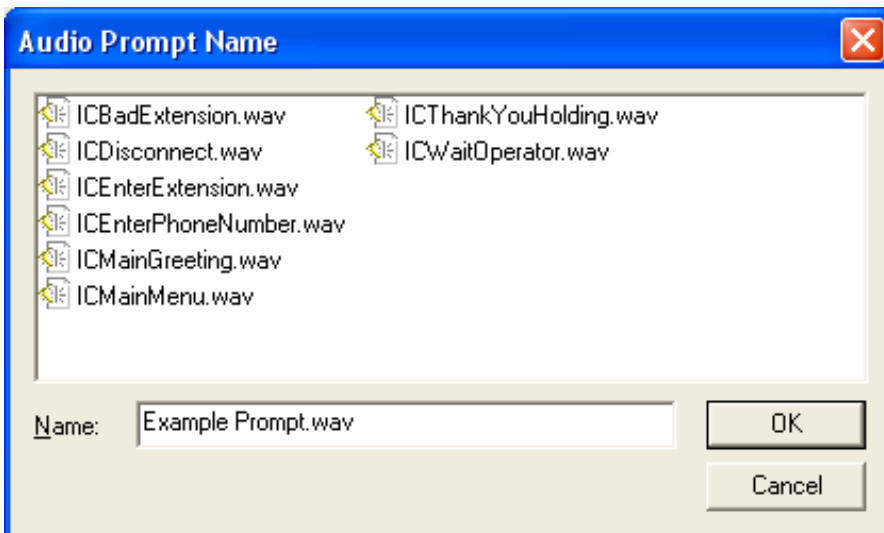

3. Press OK. When you create a new prompt, you must record it using the server's [default language](#). Attendant stores new prompts in the [default language folder](#). If you [record the prompt in another language](#) later, Attendant uses the same filename, but saves that version in a different language-specific folder. All versions of a prompt use the filename established when the

default language prompt was recorded. Alternate-language versions of a prompt are stored in the appropriate [language folder](#).

Tip

If you enter (or select) the name of an existing prompt, the default-language version of that prompt will be replaced by your new recording. This does not affect alternate-language versions of the prompt, if any exist.

Prompts in Attendant are always recorded using a telephone handset. You cannot record prompts using a microphone plugged into your PC.

4. The action you perform next depends upon whether or not you are using a SIP phone or are running Interaction Client in remote mode.
 - Your telephone will ring if you are running Interaction Client remotely, or use a SIP phone. When it does, pick up the receiver and begin speaking the prompt. See also: [Tips for recording prompts from SIP phones](#).
 - If you are not using SIP or a remote connection, you are prompted to pick up your telephone handset.

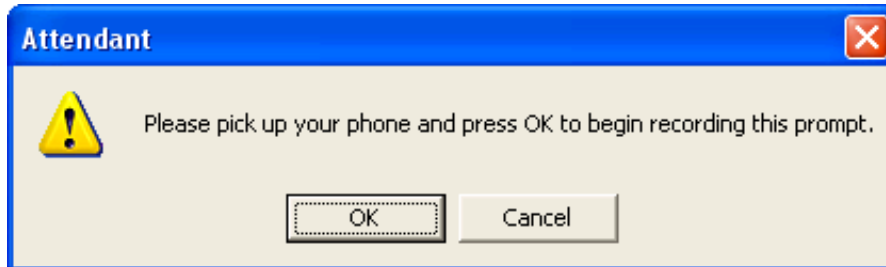

- Take your telephone off-hook. Press OK to dismiss the dialog, and listen to the audio prompt:
 - "Please record your prompt after the tone. When you are finished, press 1."
 - Begin speaking when you hear the tone.
5. When you are done, press 1 to tell the system to stop recording.
 6. Press any of the following digits to review, re-record, save, or discard the prompt:
 - To save your prompt, press 1.
 - To review (listen) to your prompt, press 2.
 - To record the prompt again, press 3.
 - To discard the prompt, press 4.
 7. When you are finished, hang up or disconnect the call.

Key Concepts

When you record a new prompt, Attendant assumes that you will record it in the default language that is defined in Interaction Administrator. Think of it this way: when Attendant asks you to supply a filename, it assumes that the default language will be used. Thereafter, you can [record the prompt in another language](#) by making a selection from the Record in Alternate Language list box—don't press Record.

You must record a prompt in the default language before you can record the prompt again in another language. Attendant uses the filename that you give to the first recording when it saves versions of the file in language-specific directories. All versions of a prompt have the same filename. Files are simply stored in different locations.

New prompts are created when you press the Record button, or press Browse to [import an existing wave audio file](#).

Related Topics

- [Manage Voice Prompts](#)

Record a prompt in another language

Follow these steps to record a prompt in a language other than the default language. You can perform this procedure from any form or dialog that contains [embedded audio controls](#). This procedure can be used to re-record any prompt, including the default language prompt.

1. Select a prompt file in the *Audio File Name* list box.
2. Select a language from the *Record in Alternate Language* list box. Checks indicate which language the prompt has been recorded in. In the example below, the prompt has been recorded in English only.

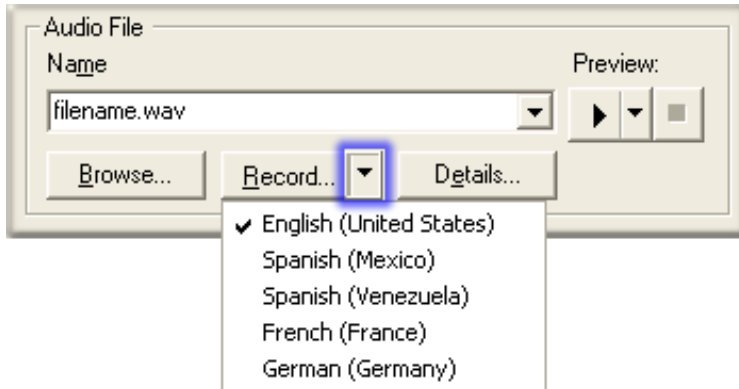

3. The action you perform next depends upon whether or not you are using a SIP phone or are running Interaction Client in remote mode.
 - Your telephone will ring if you are running Interaction Client remotely, or use a SIP phone. When it does, pick up the receiver and begin speaking the prompt. See also: [Tips for recording prompts from SIP phones](#).
 - If you are not using SIP or a remote connection, you are prompted to pick up your telephone handset.

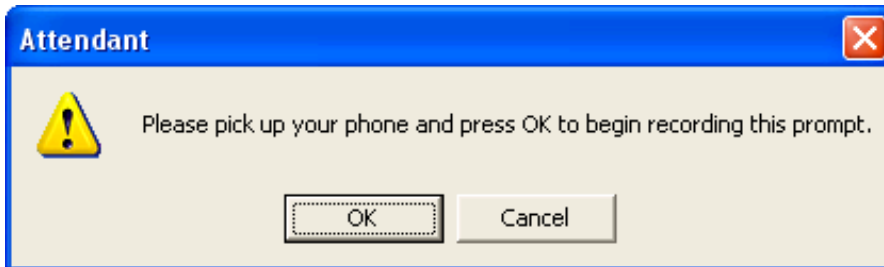

- Take your telephone off-hook. Press OK to dismiss the dialog, and listen to the audio prompt:
 - "Please record your prompt after the tone. When you are finished, press 1."
 - Begin speaking when you hear the tone.
4. When you are done, press 1 to tell the system to stop recording.
 5. Press any of the following digits to review, re-record, save, or discard the prompt:
 - To save your prompt, press 1.
 - To review (listen) to your prompt, press 2.
 - To record the prompt again, press 3.
 - To discard the prompt, press 4.
 6. When you are finished, hang up or disconnect the call.

Related Topics

- [Manage Voice Prompts](#)

Import a prompt file

This topic explains how to import an existing .wav file into Interaction Attendant, to use as the default-language prompt. You can perform this procedure from any form or dialog that contains [embedded audio controls](#).

1. Press the *Browse* button.

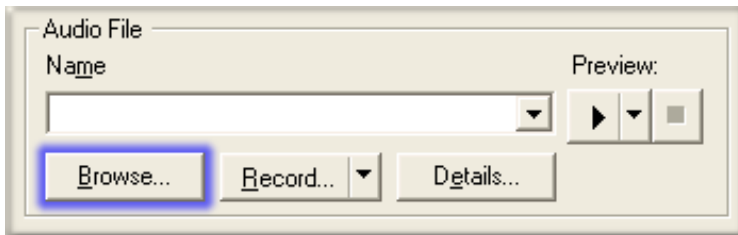

2. Use the standard File Open dialog box to select a wave audio file. Press *Open*.

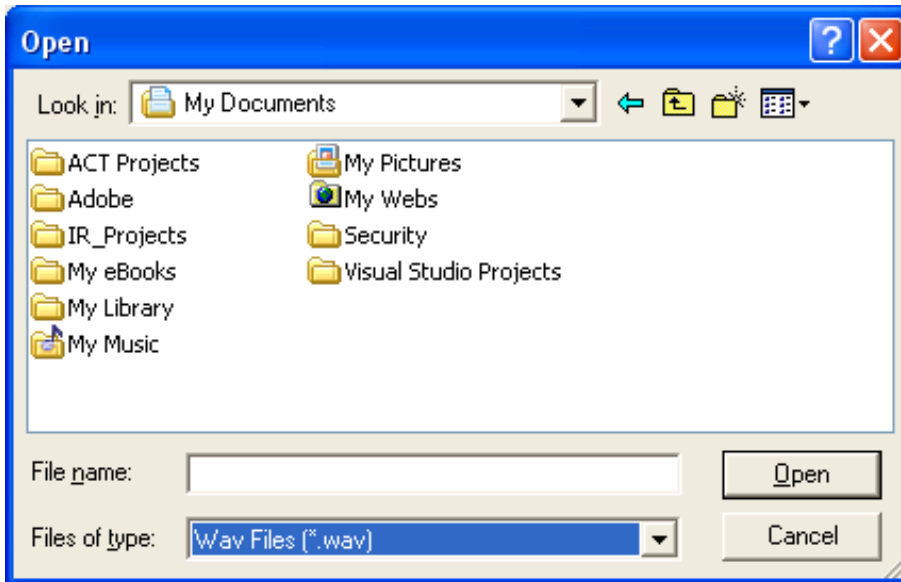

3. The filename you selected now appears in the *Name* field of the [embedded audio controls](#). You can play the file, view details about its size and format, etc. When you publish the updated configuration, the imported file will be saved on the server in the directory that Attendant uses to store wave files for the default language.

Limitations

- You can import wave audio (.wav) files only. Sound files in other formats cannot be imported.
- Attendant assumes that the imported file was recorded in the server's [default language](#). In this release of Interaction Attendant, you cannot import a file and assign it to a non-default language.
- Attendant copies imported files to the server when the configuration is [published](#).

Related Topics

- [Manage Voice Prompts](#)

An easier way to manage multi-language prompts

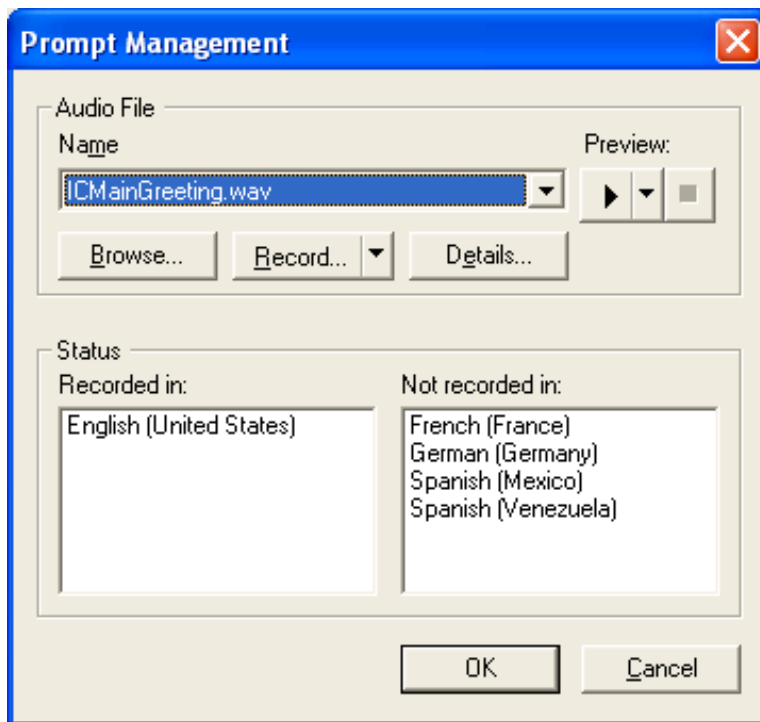

The Prompt Management dialog.

There are two ways to record prompts in Interaction Attendant. You can record prompts using [embedded audio controls](#) on a form, or you can use the *Prompt Management* dialog. The latter displays the languages a prompt has been recorded in. This makes it possible to manage multi-language prompts at a high level without opening forms.

To open this dialog, select *Multi-Language Prompts* the *Edit* menu. See [Prompt Management Dialog](#) for usage details.

Related Topics

- [Manage Voice Prompts](#)

Re-record default prompts in handlers

Some default prompts are stored in a handler rather than in wave audio files. These prompts cannot be updated in Attendant, since they are embedded in a handler and are not externally stored .wav files. This procedure explains how to optionally re-record default prompts to match the voice used in your own custom menus.

The handler named `Prompt_Attendant.ihd` contains all of Attendant's default prompts. To change these prompts, you must re-record them using Interaction Designer. The procedure below assumes that you are using the CIC version of the Interaction Designer, the CIC's graphical development tool.

A word of caution—you should not open or modify Interaction Attendant handlers other than `Prompt_Attendant.ihd`. Changing Attendant's other handlers may cause your menus to stop functioning correctly. The prompts you need to re-record are all located in `Prompt_Attendant.ihd`, and referenced from there by Attendant's other handlers using Play Prompt Extended tools.

Steps to Complete

1. Start Interaction Designer.
2. Pull down the File menu and select Open.

3. Select `\\c\handlers\30handlers\<lang>\Prompt_Attendant<lang>.ihd`. Press the Open button.

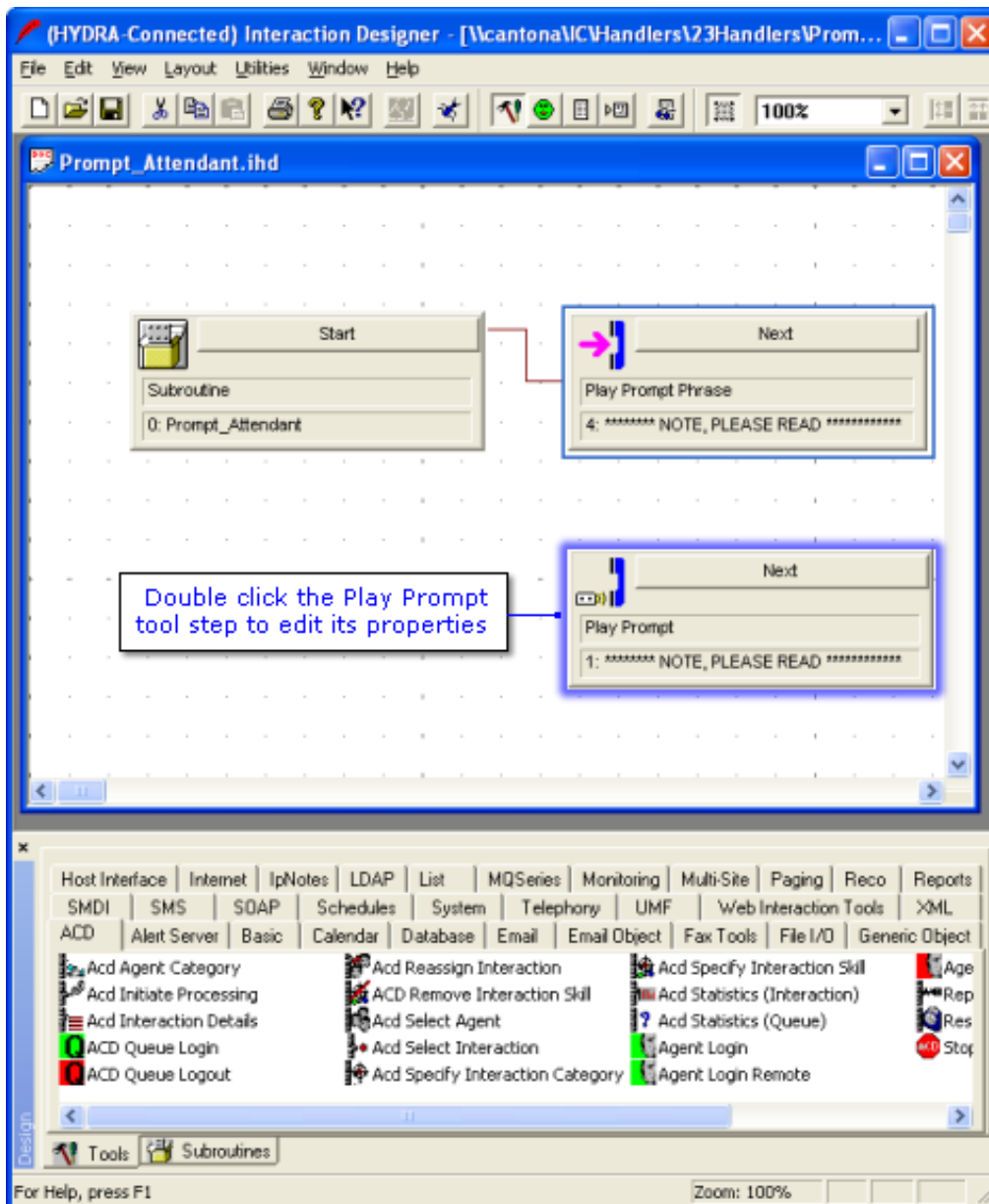

4. Double-click the *Play Prompt* step to open its Property sheet.
5. Click on the *Inputs* tab. Then press the *Edit* button.

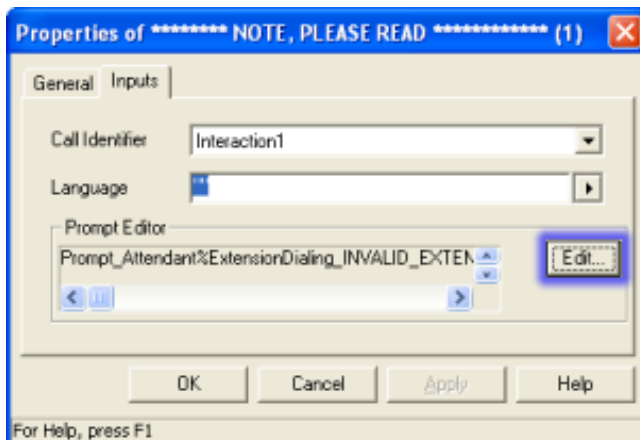

6. Select a prompt to re-record, and press click the *Record* button to begin recording.

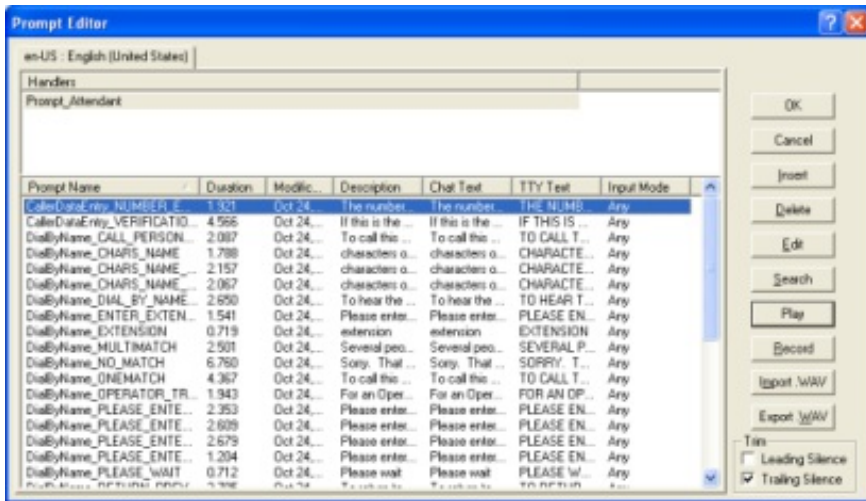

7. Repeat step 3 to re-record other prompts as needed.
8. Press *OK* to close the *Prompt Editor* window.
9. Press *OK* again to close the properties page.
10. Select *Save* from the *File* menu to save changes.
11. Select *Publish* from the *File* menu to put changes into effect. Interaction Attendant will begin using the new prompts immediately.

Transcript of the default prompts

Here is a transcription of default voice prompts in the *Prompt_Attendant* handler:

Handler Name/Prompt Name	Transcription
CallerDataEntry_NUMBER_ENTERED_IS	The number you entered is...
CallerDataEntry_VERIFICATION_MENU	If this is the desired entry, press 1. Otherwise, to reenter, press 2.
DialByName_CALL_PERSON_NOW	To call this person now, press 1.
DialByName_CHARS_NAME	characters of your party's name...
DialByName_CHARS_NAME_FIRST	characters of your party's first name...
DialByName_CHARS_NAME_LAST	characters of your party's last name...
DialByName_DIAL_BY_NAME_ENTIRE_DIR	To hear the company directory, press the pound sign.
DialByName_ENTER_EXTENSION	Please enter the extension number.
DialByName_EXTENSION	extension
DialByName_MULTIMATCH	Several people match that entry. They are . . .
DialByName_NO_MATCH	Sorry. That does not correspond to a known name. To hear the company directory, press the pound key. To try again,...
DialByName_ONEMATCH	To call this person now, press 1. To try again, press the star key.
DialByName_OPERATOR_TRANSFER_OPTION	For an operator, press zero.
DialByName_PLEASE_ENTER_CHARS_NAME	Please enter the characters of your party's name.
DialByName_PLEASE_ENTER_CHARS_NAME_FIRST	Please enter the characters of your party's first name.
DialByName_PLEASE_ENTER_CHARS_NAME_LAST	Please enter the characters of your party's last name.
DialByName_PLEASE_ENTER_FIRST	Please enter the first . . .
DialByName_PLEASE_WAIT	Please wait.
DialByName_RETURN_PREVIOUS_MENU	To return to the previous menu, press the star key.
DialByName_USE_7_Q_9_Z	...use seven for 'Q' and nine for 'Z'
ExpressionEvaluation_FALSE	False
ExpressionEvaluation_TRUE	True
ExtensionDialing_INVALID_EXTENSION	Sorry, this is not a valid extension.
FaxBack_IVR_FAX_SEND_FAILURE	An error occurred while sending your fax.
FaxBack_IVR_FAX_SEND_SUCCESSFUL	Your fax has been successfully sent.
ProcessAcdWait_ACD_AUDIO_AHEAD	...calls ahead of you.
ProcessAcdWait_ACD_AUDIO_APPROX	...will be approximately...
ProcessAcdWait_ACD_AUDIO_ESTIMATED_WAIT	Your wait time...
ProcessAcdWait_ACD_AUDIO_LESS_MINUTE	...should be less than one minute.
ProcessAcdWait_ACD_AUDIO_MINUTE	Minute
ProcessAcdWait_ACD_AUDIO_MINUTES	Minutes
ProcessAcdWait_ACD_AUDIO_NO	No
ProcessAcdWait_ACD_AUDIO_POSITION	There are currently...
ReceiveFax_PRESS_START_NOW	You may press 'Start' on your fax machine, now.

Related Topics

- [Manage Voice Prompts](#)

Tips for recording prompts from SIP phones

In releases of Attendant prior to 2.2 SR-A, prompts could not be recorded using SIP phones. Using the SIP platform, neither users nor administrators could record prompts via the phone handset in Attendant. When a user selected Record, he was prompted to pick up the handset and select OK. The dialog box was continually re-displayed after OK was selected.

To resolve this problem, Interaction Attendant no longer checks phone status. When a user clicks on record, he is prompted to enter the name of the .wav file to record and then the recording process begins.

- If the user is a SIP user, the SIP phone will ring to start the recording process.
- If the user is off-hook, station audio will play to guide the user through the process of recording a prompt.
- If the user is on-hook, a new station audio object is placed in the user's queue, *but the user is not alerted*. The user must pick up the phone without being prompted to do so.

Related Topics

- [Manage Voice Prompts](#)

Configure CIC to support additional languages

Languages are defined in Interaction Administrator. Interaction Attendant lists the names of supported languages in audio-related forms and dialogs, so that you can select a particular language for playback or recording of a voice prompt. This topic explains how to configure a CIC Server to support additional languages.

If you need to support a language that does not appear in Interaction Attendant's list of available languages, use the procedure below to add a new language entry to the list of languages supported by the cUSTOMERInteraction Center server:

1. Run Interaction Administrator.
2. Click on the *System Configuration* container in the tree view.
3. Open the property sheet for the Configuration entry by double-clicking *Configuration* in the list view. Click on the *Languages* tab.

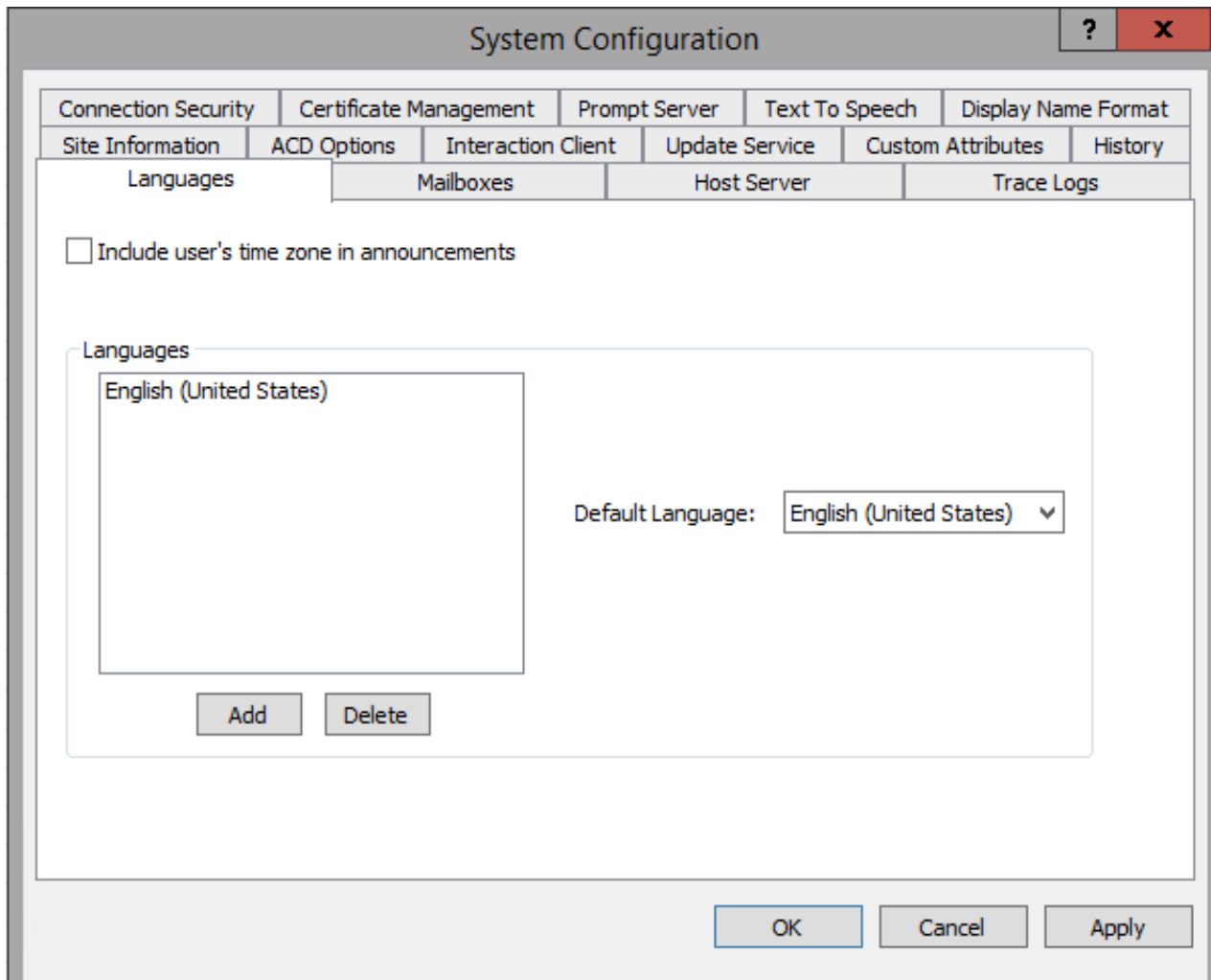

4. Press *Add* to open the Languages dialog.

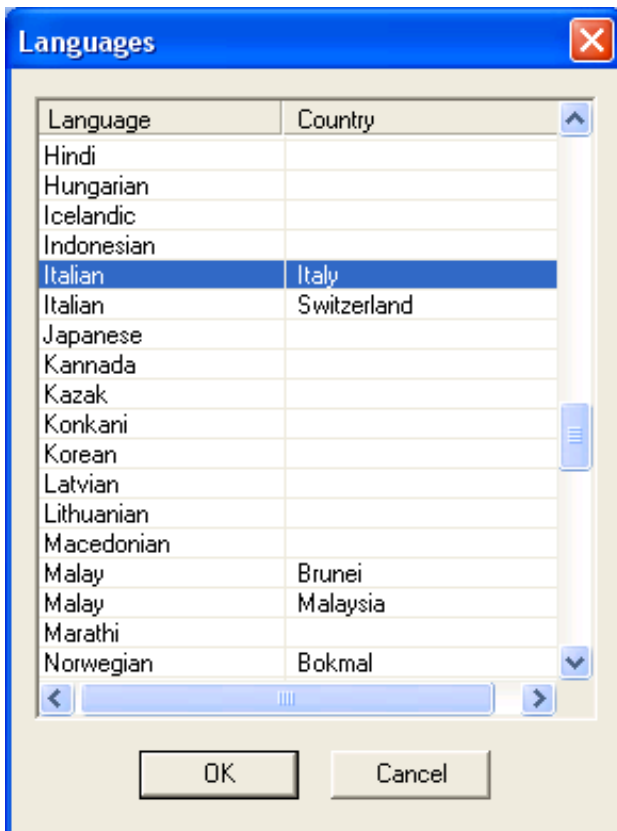

5. Select a language from the list. Then press *OK*.
6. Repeat steps 5-6 to add additional languages if need be.
7. Press *OK* to close the *System Configuration* property sheet.
8. Close Interaction Administrator by selecting *Exit* from the *File* menu.

Related Topics

- [Manage Voice Prompts](#)

Manage Configuration Files

The call flow interactions that you design in Attendant are called *configurations*. Configurations can be connected, locked, loaded, published, exported, imported and disconnected. You can export a server's configuration data to an Attendant file (*.att) to create a backup, or a file that can be imported into another server. Configuration files back up existing servers, and make it easier to configure multiple servers.

Understanding Packages vs. Configurations

When part of a call flow is saved to disk, the resulting file is called a *package*. The command that saves a portion of the call flow is called *Package*, to distinguish it from *Export*, which saves the entire call flow in a configuration file. For procedural details, see [export a configuration file](#) and [export a package file](#).

Packages allow part of a call flow to be moved from a test environment to a production server. Packages can be used to create a template call flow that can be loaded onto a server and then customized.

Configuration files have an extension of .att. Package files have an .atp extension. The difference between a *package* (created using the *Package* command) and a *configuration* (created using the *Export* command) is that:

A configuration always describes the entire Attendant tree: all profiles and everything below it. A package is a sub-section of a tree that could be any node along with all of its children, grandchildren and so on. A package could contain a profile, a schedule, a complex action node, or any other combination of call flow logic.

When you import a *configuration*, all of the existing call flow is replaced by the imported configuration, but when you import a package, nothing is deleted. The nodes in the package are simply added to the existing configuration. See [import files](#).

Connect opens the last published configuration

When you login to a server with Attendant, you become [connected](#) to the configuration that is currently running, and the call flow is loaded into Attendant for editing. If no one else is editing the configuration, Attendant [locks](#) it for your exclusive use. This prevents other persons from publishing the configuration while you are editing it. Attendant notifies you if the configuration is locked by someone else.

Export copies the configuration to a disk file

[Exporting](#) a configuration saves a copy of it to a file. You can export an inbound, outbound, or operator configuration in one of three ways:

- As a *server-specific backup* that can be imported only by the server from which it was copied.
- As an *exact full copy* that can be loaded onto a similarly configured server. This is typically used to move a configuration from a test server to a production server.
- As a generic *configuration template* that can be loaded on any server. This contains the general call flow layout, but without server-specific information, such as workgroup names, user names, or audio files. The resulting file can be loaded onto a server and customized to match the destination server. This option does not require servers to be identically configured. It is geared for partners and administrators who manage multiple sites.

Import opens a configuration file for editing in Attendant

[Import](#) reads a configuration file (or package) from disk into Attendant for editing. Import does not automatically replace the server's running configuration. You must explicitly publish it.

Load Active Configuration

[Load Active Configuration](#) abandons the changes that you have made and loads the configuration that is currently active and taking calls on a server.

Publish puts the loaded configuration into effect

When you edit a configuration, you can [publish](#) it to put changes into effect. Partial or unfinished configurations can be exported for later editing. If you connect to a configuration that has been locked by another user, you can still use Attendant to edit the configuration, but you cannot publish it. When you finish making changes, you can export them to disk, and import them later.

Disconnect closes the connection to the server, and its configuration

When you [disconnect from a server](#), Attendant's connection to its Notifier subsystem is released, your lock on the data (if any) is removed, and the configuration is removed from the tree structure. If you disconnect without saving changes first, Attendant provides an opportunity to [save your work](#).

Related Topics

- [Stale Lock Dialog](#)
- [Same User Lock Dialog](#)



Publish a Configuration

The *Publish* command saves loaded call flow configurations, and puts them into effect immediately.

Scope of Publish Command

If more than one configuration is loaded, care must be taken not to publish a configuration unintentionally. The publish command applies to [all loaded configurations](#) unless you use the [Servers](#) dialog to restrict publishing to specific servers. (See publish selected configurations below.)

Publish a Single Configuration

If only one configuration is open for editing, follow these steps to publish changes:

1. Pull down the *File* Menu and select *Publish*, or press the Publish toolbar button (). The Publish confirmation dialog appears:

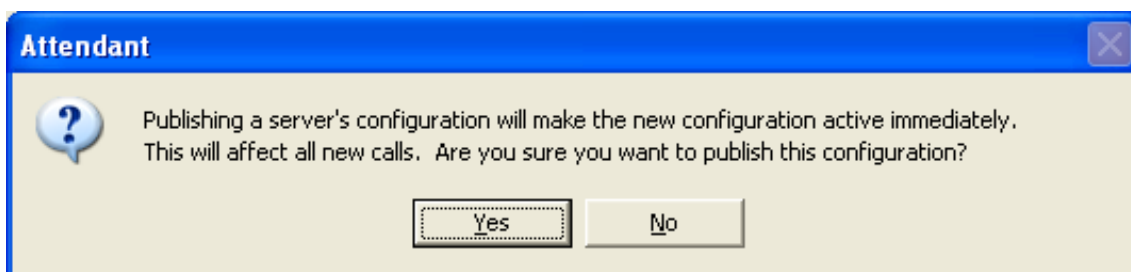

2. Press *Yes* to proceed. Published changes go into effect immediately. Publishing updates System and Application logs. When a configuration is published, Attendant records publishing errors, warnings, and other problems to the System Error log. It also adds entries to the Application log, to note user name, station name, time, and the profiles and schedules that changed.

Publish Selected Configurations

If more than one configuration is loaded in the tree, you should use the Manage Servers command to select a subset of servers to publish:

1. Pull down the *Edit* menu and select *Manage Servers*.
2. Ctrl-click in the server list to select the names of servers that you wish to update. Then press the *Publish* button.

Locked Configurations

You cannot publish if the Server configuration is locked by another user. When you connect to a server, Attendant displays the [Attendant In Use](#) dialog if someone else is updating its auto-attendant configuration.

It indicates this by displaying a padlock icon () next to the Server node in the tree. In this situation, you can edit the configuration and [export](#) it to a file, but you cannot publish since the configuration is locked by someone else.

Publishing Errors

If you modify a configuration and introduce errors, Interaction Attendant won't allow you to publish until all errors are fixed. The following message is displayed if you attempt to publish settings that contain errors:

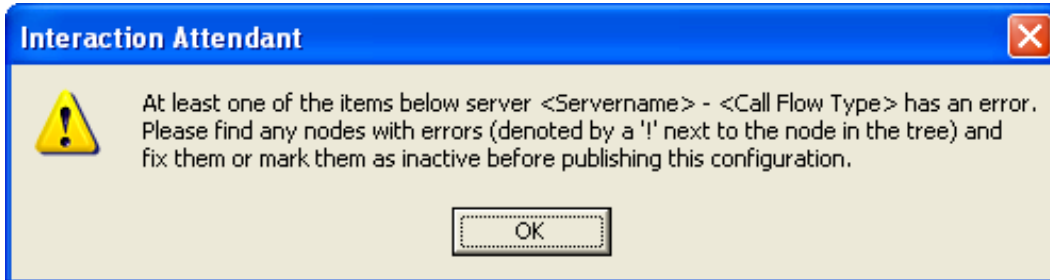

In the actual dialog, <Servername> is replaced by the name of your CIC server, and <Call Flow Type> is replaced by Inbound Call Configuration, Outbound Call Configuration, or Operator Call Configuration.

Tip—If you hover the mouse cursor over a node that has an error indicator, Interaction Attendant will display a tool tip that describes the error condition.

If you must stop working in Attendant, you can save the broken configuration as an Attendant Configuration File, using the File | Export File command. Later, when you have time to fix the problem, you can reload the configuration using the File Import command, fix the problems, and publish changes.

Related Topics

- [Manage Configuration Files](#)
- [Visual Indicators in the Tree](#)
- [Stale Lock Dialog](#)
- [Import Files](#)
- [Servers Dialog](#)

Import Files

The Import command imports a call flow configuration or package. If you do not have appropriate modify rights, Interaction Attendant will create a new profile instead of overwriting an existing one.

To import a package file:

1. Open the *File* menu and select *Import File*, or press the *Import from File* button () on the main toolbar.
2. When a standard *File Open* dialog appears, select an Attendant package (*.atp) to import. Then press *Open*. A message appears, asking if you want to overwrite the existing profile.

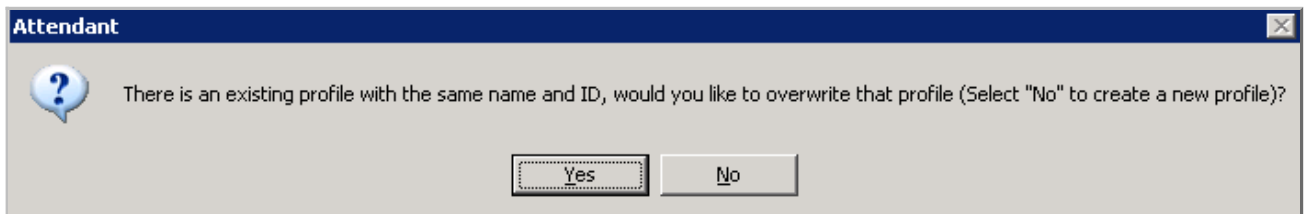

3. To overwrite the existing profile, click the Yes button.
4. To create a new profile, click the No button. Attendant prompts for the location in the tree where the file's contents will be inserted. Use the list box to select this. Press *OK*.

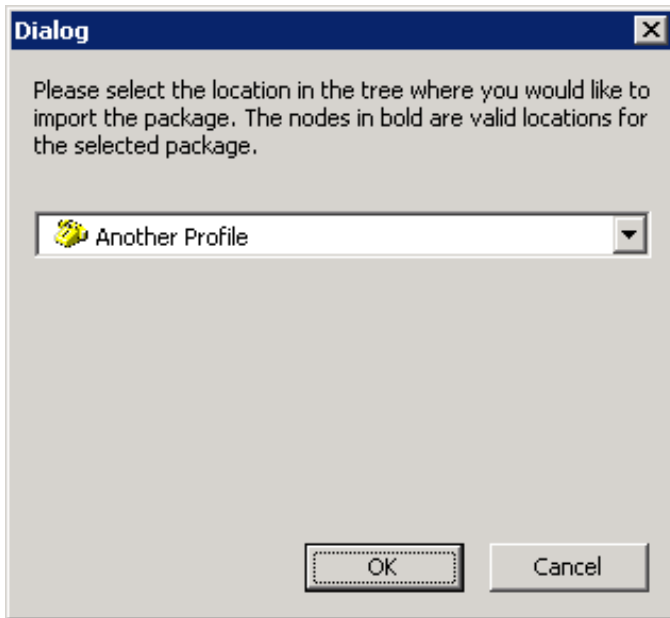

5. Attendant displays a dialog to confirm that the contents of the external file were inserted:

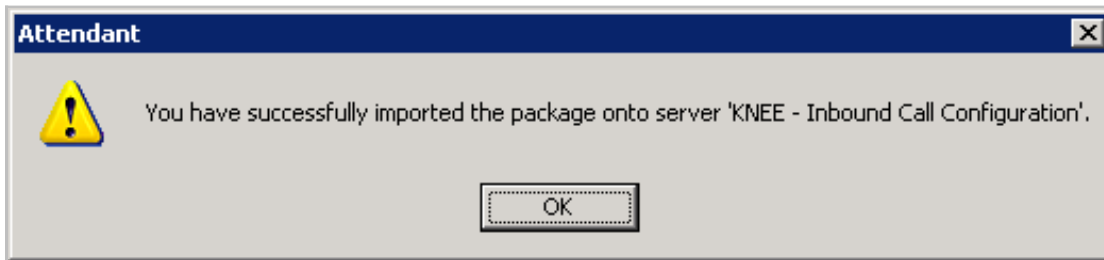

6. Press *OK* to dismiss this dialog.

To import an Attendant configuration file:

1. Open the *File* menu and select *Import File*, or press the *Import from File* button () on the main toolbar.
2. When a standard *File Open* dialog appears, select an Attendant configuration file (*.att). Then press *Open*. The remaining steps apply only if you are importing a configuration file:
3. Attendant analyzes the file to determine the type of configuration data that it contains. The prompt that appears next depends upon the type of backup information found in the file. Attendant recognizes three backup types:
 - *Backup* configuration files contain server-specific information that must be imported by the same server. If you are importing this type of file, skip to Step 4.
 - *Full* configuration files contain an exact copy of one server's configuration that can be loaded on to an identically configured server. This is designed to move a configuration from a test server to a production server. The source server must be identical to the destination server in terms of line names, workgroup names—everything except server name and password. If you are importing this type of file, skip to Step 5.
 - Configuration *Template* files contain generic configuration data that can be loaded onto any server. This file type contains the general Attendant layout, but without server-specific information, such as workgroup names, user names, or audio files. The resulting file can be loaded onto a server and customized to match the destination server. This option is geared for partners and administrators who manage multiple sites. It does not require servers to be identically configured. If you are importing this type of file, skip to Step 6.
4. If the file is a *Backup* configuration, Attendant prompts for confirmation.

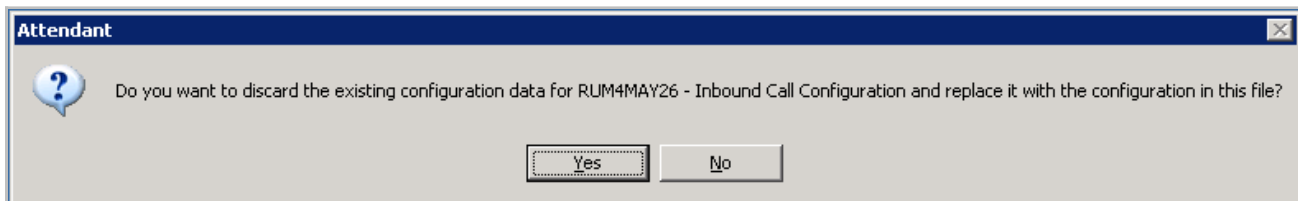

Press **Yes** to replace the loaded configuration with the contents of the file, or press **No** to cancel. Remember – loading a configuration has no effect on the server until it is **published**. Attendant displays a dialog to confirm the backup configuration was inserted:

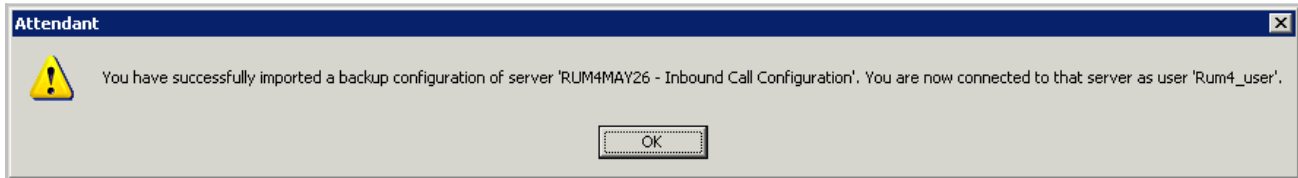

Press **OK** to dismiss the dialog.

Attendant will not import a configuration for a server that is unreachable on the network. This prevents it from crashing while trying to disconnect from a non-existent server. If it cannot locate the specified server, it alerts the user and aborts the import operation.

5. If a *Full Configuration* is detected, Attendant prompts for a server to connect to, since the file does not contain any information about the origin of the data. It displays a dialog that lists connected server configurations.

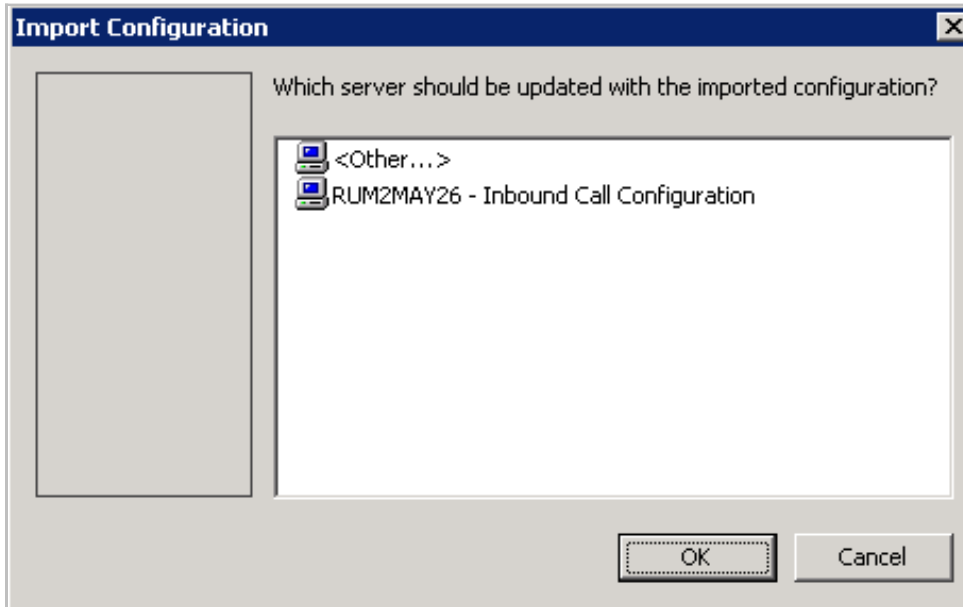

Select a destination server from this list, or select *<Other>* to **connect** to an unlisted server. When *Other* is selected, the configuration is loaded into another server, leaving the configuration of currently connected servers intact. If you choose an existing connection, you are asked to confirm the import operation:

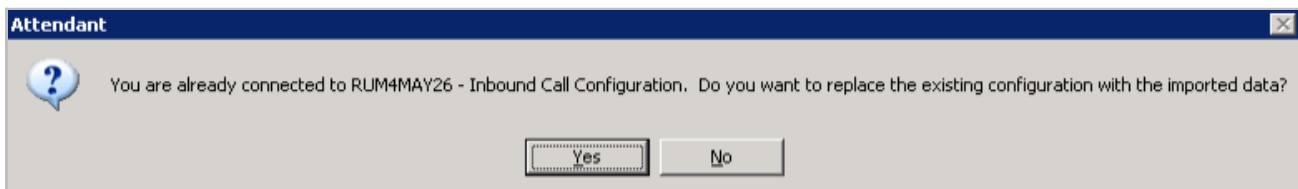

Select **Yes** to import the Full Configuration, or select **No** to cancel the import command. Attendant displays a dialog to confirm the configuration was inserted:

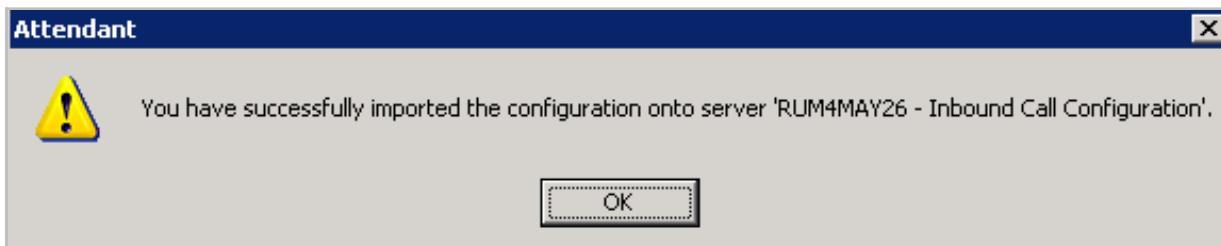

Press **OK** to dismiss this dialog.

When a Full Configuration is imported, Attendant flags nodes that are in error due to missing prompt files, differences in workgroup settings, etc. For example, if a wave file was recorded on the test server and does not exist on the production server, Attendant would flag that node so that you can recreate the prompt on the production server. Another example might be a workgroup that is named Support on one CIC system, but is called Customer Support on the other.

6. If a configuration *Template* is detected, Attendant prompts for a server to connect to, since the file does not contain any information about the origin of the data. It displays a dialog that lists connected server configurations.

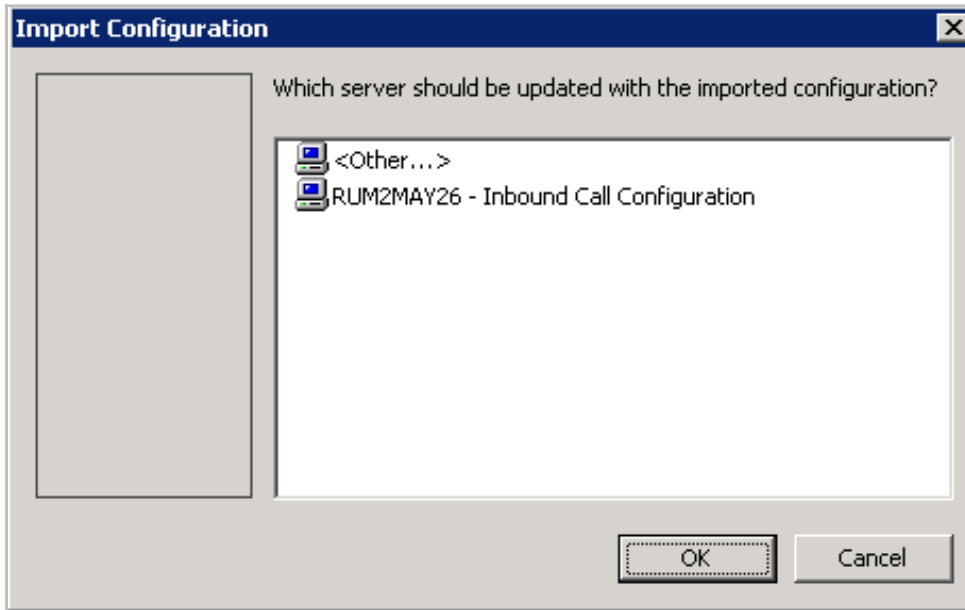

Select a destination server from this list, or select *<Other>* to **connect** to an unlisted server. If you choose an existing connection, you are asked to confirm the import operation:

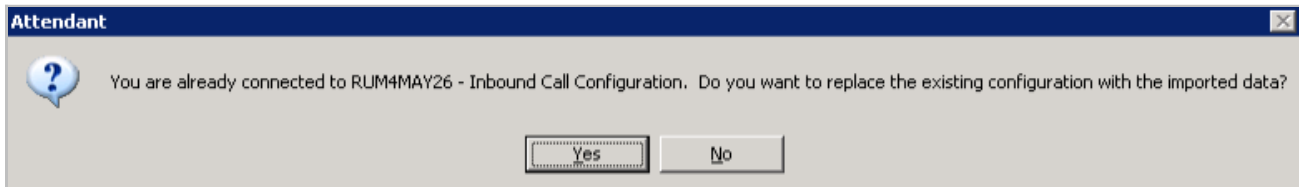

Select *Yes* to import the configuration template, or select *No* to cancel the import command. Attendant displays a dialog to confirm the template was inserted:

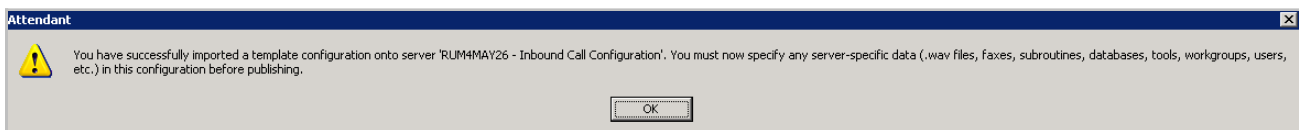

Press *OK* to dismiss this dialog.

When a template is imported, Attendant recreates the call flow tree exactly, but any item of information that is server-specific (user names, workgroup names, audio files, skills, etc.) is left blank. Incomplete nodes are flagged as errors, so that you can customize these nodes to match the destination server.

Starting with Attendant 2.4, the import feature was enhanced to display information about the type of data imported; whether it was a server-specific backup, full configuration, or template file. Attendant displays an import results message when the import ends.

- If a *backup* configuration was imported, the message indicates which server the user is connected to and the account used to log in.
- If a *full* configuration was imported, the message indicates whether the full import was successful.
- If a *template* was imported, it tells you that it was a template import and describes the information that must be supplied before the configuration can be published.

7. Resolve errors, if any are visually indicated in the tree.

Import loads a configuration file into the interface for editing. You must use the [Publish](#) command to "activate" imported configurations. If the imported .att file contains information about other servers, those configurations are loaded into Attendant's user interface.

Scope of Publish Command

Care must be taken not to publish a configuration unintentionally. The publish command applies to all loaded configurations unless you use the [Servers](#) dialog to restrict publishing to specific servers.

To publish configurations for all servers displayed in the user interface, select Publish from the File menu or press the  (Publish) button on the main toolbar.

To publish configurations for selected servers, pull down the Edit menu and select Manage Servers. Ctrl-click in the server list to select the names of servers that you wish to update. Then press the Publish button.

Related Topics

- [Visual Indicators in the Tree](#)
- [View information about an error](#)
- [Error Resolution](#)
- [Export a Configuration File](#)



Load Active Configuration

Attendant allows you to load the active configuration that is running on a server. Follow these steps to abandon the changes that you have made and load the configuration that is currently active and taking calls on a server:

1. Select the server node in the tree view.
2. Pull down the *Edit* menu and select *Load Active Configuration*. This command is disabled unless a server node is selected and some part of its configuration has changed.

Export a Configuration file (entire call flow)

The *Export* command saves call flow configurations in Attendant configuration (*.att) files. Export saves the entire inbound, outbound, or operator call flow that is open for editing. If you want to export a portion of the call flow, use the procedure described in [export a package file](#). A future release of Attendant may export all three call flow types at once. Right now, you must export different call flows separately.

At export time, Attendant prompts you to select the amount of server-specific information to include in the export file. This configures the export file for use as a server-specific backup, portable "full" configuration, or as an application template.

1. Start Attendant and connect to call flows you want to export.
2. Pull down the *File* menu and select *Export File*. The [Export Wizard](#) appears, prompting for the type of export:

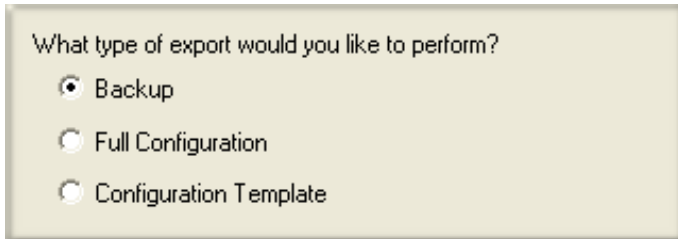

What type of export would you like to perform?

Backup

Full Configuration

Configuration Template

Backup creates a server-specific configuration file that can be imported only by the server from which it was exported. This type of export saves server name, username, and password in the export file. You can Backup more than one server at a time. Its functionality is identical to backups that could be performed in releases of Attendant prior to release 2.3.

Full Configuration exports an exact copy of one server's configuration that can be loaded onto any other server. This saves the entire server configuration, except for the server name, login ID and password. This makes it possible to move a configuration from a test server to a production server. The test server must be identical to the production server in terms of line names, workgroup names—everything except server name and password.

When the file is imported, Attendant prompts for a server to connect to, since the file does not contain any information about the origin of the data. Attendant analyzes the configuration and flags nodes that are in error (due to missing prompt files, differences in workgroup settings, etc.). For example, if a wave file was recorded on the test server and does not exist on the production server, Attendant would flag that node so that you can recreate the prompt on the production server.

Configuration Template exports a generic configuration that can be loaded onto any server. This export type saves the general Attendant layout, but does not save server-specific information, such as workgroup names, user names, or audio files. The resulting file can be loaded onto a server and customized to match the destination server. This option is geared for partners and administrators who manage multiple sites. It exports a general configuration that does not require servers to be identically configured.

For example, a workgroup might be named Support on one CIC system, and Customer Support on another. When the template is imported, Attendant recreates the call flow tree exactly, but any piece of information that could be server-specific (user names, workgroup names, audio files, skills, etc.) is left blank. Incomplete nodes are flagged as errors, so that you can customize these nodes to match the destination server. Configuration templates allow developers to build custom solutions for customers, or to deploy an IVR interaction to many servers in an organization.

A backup export can save configurations for multiple servers. Full Configuration and Configuration Template exports apply to a single server only.

2. Follow the on-screen instructions as prompted by the [Export Wizard](#).

Related Command Line Parameters

Full and backup configuration export modes can be specified when starting Attendant using [optional command line parameters](#). The command line options for specifying configuration export are:

- `/export=[filepath]` exports a backup configuration, where [filepath] is replaced with the full path and filename to which you want to export the backup configuration.
- `/fullexport=[filepath]` exports a full configuration, where [filepath] is replaced with the full path and filename to which you want to export the full configuration.

Related Topics

- [Export Wizard](#)
- [Import Files](#)
- [Publish a configuration](#)
- [Servers Dialog](#)



Export a Package file (portion of call flow)

The Package command exports part of a call flow to a file. If you wish to export an entire call flow, see [export a configuration file](#). When a portion the call flow is saved to disk, the resulting file is called a *package*. A package is a sub-section of a tree that contains a node along with all of its children, grandchildren and so on. For example, a package might contain a profile, a schedule, a complex action node, or any other combination of call flow logic.

Use packages to move portions of a call flow from a test environment to a production server, or to create "template" call flows that can be imported onto another CIC server and then customized.

1. Start Attendant and connect to call flows you want to package.
2. Select a node in the tree to export.
3. Pull down the *File* menu and select *Package*, or...

press the *Package* toolbar icon () , or...

right-click the selected node and choose Package from the context menu.

4. The [Export Wizard](#) appears to prompt for the type of export. Select *Full Configuration* or *Configuration Template*. Then press the *Next* button to proceed.

Full Configuration

Creates a package file that contains an exact copy of the selected nodes' configuration. This package option is useful for moving part of a call flow from a test environment to a production server.

Configuration Template

Creates a package file that contains a generic copy of the selected nodes' configuration. The package will contain the general Attendant layout of the selected nodes, but will not contain any server specific information such as workgroup or user names, or audio files. This option can be used to create a template call flow that can be loaded onto a server and then customized.

5. When the Save dialog appears, specify a filename and path. Package files have an .atp extension. Press *Finish* to create the file.

Related Topics

- [Export Wizard](#)
- [Import Files](#)

Working with Speech Recognition

In Interaction Attendant, you can set up and configure speech recognition to offer callers the ability to navigate the IVR by verbally communicating their choices instead of (or in addition to) using a keypad to enter choices numerically.

For example, if a caller wants to find the balance on a credit card account, he or she might hear one of the following:

- “To hear your current balance, press 1.”
- “To hear your current balance, say ‘Balance’.”
- “To hear your current balance, press 1 or say ‘Balance’.”

Speech engines defined by your administrator match a caller’s spoken audio to menu operations you configure with keywords and phrases, and Interaction Attendant transfers the caller to the appropriate destination.

In some cases, callers might use different terms to refer to a department or choice. For example, “customer service”, “customer support”, and “support” may all be contained in one department. You can add multiple keywords and phrases to increase the speech engine’s ability to find an appropriate match to the caller’s request.

To get started

1. [Enable Speech Recognition at the Profile level](#): Before you can use the speech recognition feature, you must first enable it at the profile level.
2. [Configure Speech Recognition for Schedules and Menus](#): Next, at the schedule or menu level, optionally configure such settings as confidence levels, timeouts, and prompts to play when the speech engine does not recognize the spoken audio or finds multiple matches. By default, these settings use the configured parameters set by your administrator in Interaction Administrator.
3. [Add keywords or phrases to Speech Recognition in Inbound Call Operations](#): Finally, in each inbound call operation included in the schedule, set up keywords and phrases. You can also select the language to use, and which node to navigate to if the speech engine locates a match anywhere in the schedule.

Speech Recognition overview

With Interaction Attendant’s speech recognition feature, you can designate words and phrases associated with any schedule, profile, or menu node for inbound calls, providing callers the ability to verbally select the options they want, rather than using the telephone keypad to navigate the IVR. You can select a speech engine to compare a caller’s spoken audio to a list of keywords or phrases. Speech engines are added and configured by your administrator in Interaction Administrator.

When you configure a schedule or menu in Interaction Attendant, you can define one of the following options to present to callers who enter that schedule or menu:

- Specify the numerical key a caller presses to select the schedule or menu item
- Set speech recognition to interpret a caller’s verbal selection
- Provide both numerical and verbal options, giving users the choice of using the keypad or verbally communicating which menu they want to reach

Speech Recognition default settings

Your administrator configures the Interaction Attendant speech recognition settings in Interaction Administrator. Here, the administrator defines such parameters as minimum confidence levels, timeouts, audio prompts played to the caller if the speech engine cannot determine the caller’s selection, manage custom attributes, and record notes about configuration settings and changes. If you have the appropriate rights, you can override these default settings for any schedule or menu.

Enable Speech Recognition

Before you give callers the ability to verbally indicate their menu selections, you must first [make speech recognition available on menus](#). To enable speech recognition, open the desired profile and select the **Configure Speech Recognition** button. By default, speech recognition is enabled for the company directory only. If you choose to enable speech recognition on menus and also leave it enabled for the company directory, callers will not be prompted to say the name of the person they want to reach. If you want to keep this option, you must modify the main greeting prompt to present the option to the caller.

Configure Speech Recognition for Schedules or Menus

If you have the appropriate rights granted by your administrator, you can [override the speech recognition default settings](#) at the schedule or menu level. Your administrator configures these settings in Interaction Administrator. For example, you can:

- Adjust the minimum confidence level, or the highest scoring the phrase must receive to achieve a successful match.
- Set the maximum time to wait after caller provides a valid speech input and stops talking before the system presents a positive match.
- Choose the length of time to wait after caller stops talking and when the verbal selection is invalid before the system indicates no match is found.
- Specify the length of time allotted to the caller to make his or her verbal selection before the system times out and either prompts the caller to make a selection or disconnects the call.
- Select which audio prompts the system presents to the caller when the speech engine cannot find a specific match and the order in which to play them.

Configure Speech Recognition for Inbound Call Operations

For every inbound call operation, you can [enter keywords and phrases a caller might use to verbally indicate the location to which they want to transfer](#). You can choose from a list of languages and you can enter multiple words and phrases, particularly useful if callers use different terminology for the same destination. For example, callers who want to reach the customer service department might say “customer service”, “customer support”, “support”, “product assistance”, and so on. If the speech recognition engine finds multiple matches to a caller’s request, or if it does not find an appropriate match, Interaction Attendant begins the invalid or ambiguous input prompt sequence to give the caller the opportunity to narrow down a selection or clarify his or her choice.

Enable Speech Recognition for a Profile

Speech recognition is enabled at the profile level. Before you give callers the ability to verbally indicate their selection, you must first make speech recognition available on menus.

To enable speech recognition for schedules and menus in a profile

1. Select the desired profile and click **Configure Speech Recognition**. The **Speech Recognition Configuration** dialog box for Profiles opens:

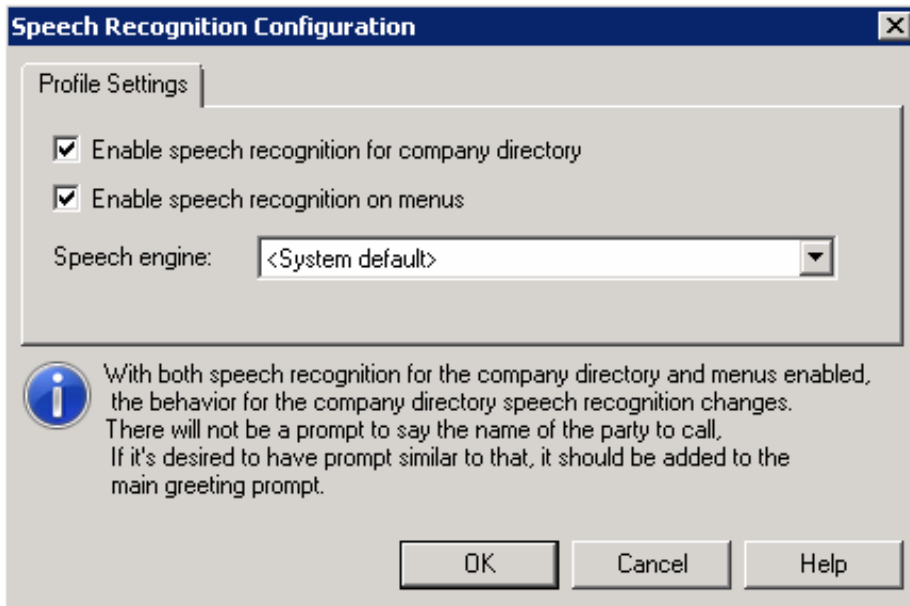

2. By default, speech recognition is enabled for the company directory. If enabled, Attendant listens for company directory speech from the caller during the initial processing of the call. Once processing of the call moves to another step in Attendant, Attendant no longer listens for company directory speech from the caller. Clear the **Enable speech recognition for company directory** check box to disable speech recognition for company directory.
3. Select the **Enable speech recognition on menus** check box. If you choose to enable speech recognition on menus and leave it enabled for the company directory, callers will not be prompted to say the name of the person they want to reach. To keep both options selected and direct the system to ask callers to say the name of the person or department they wish to transfer to, you must modify the main greeting prompt to include this option for the caller. You can re-record the prompt in the profile's Profile Greeting area. If your prompts are professionally recorded, obtain an updated recording from the recording company and place it in the Attendant audio files directory on the CIC server (usually [\\3\IC\Resources\InteractionAttendantWaves](#)).
4. Optionally select a speech engine from the **Speech engine** drop-down list.
5. Click **OK**.

Configure Speech Recognition for Schedules and Menus

If you have the appropriate rights granted by your administrator, you can override the speech recognition default settings configured in Interaction Administrator. For example, you can:

- **Minimum confidence level:** Adjust the minimum confidence level, or the highest scoring the phrase must receive to achieve a successful match.
- **Complete timeout:** Set the maximum time to wait after caller provides a valid speech input and stops talking before the system presents a positive match.
- **Incomplete timeout:** Choose the length of time to wait after caller stops talking and when the verbal selection is invalid before the system indicates no match is found.
- **Speech timeout.** Specify the length of time allotted to the caller to make his or her verbal selection before the system times out and either prompts the caller to make a selection or disconnects the call.
- **Invalid or ambiguous input prompt sequence:** Select which message or messages the system presents to the caller, and the order in which to play them, when the speech engine cannot find a specific match and the order in which to play them.

To configure speech recognition for schedules and menus

1. Select the desired schedule or menu and click **Configure Speech Recognition**. The appropriate **Speech Recognition Configuration** dialog box opens (for menus, click the **Menu Settings** tab):

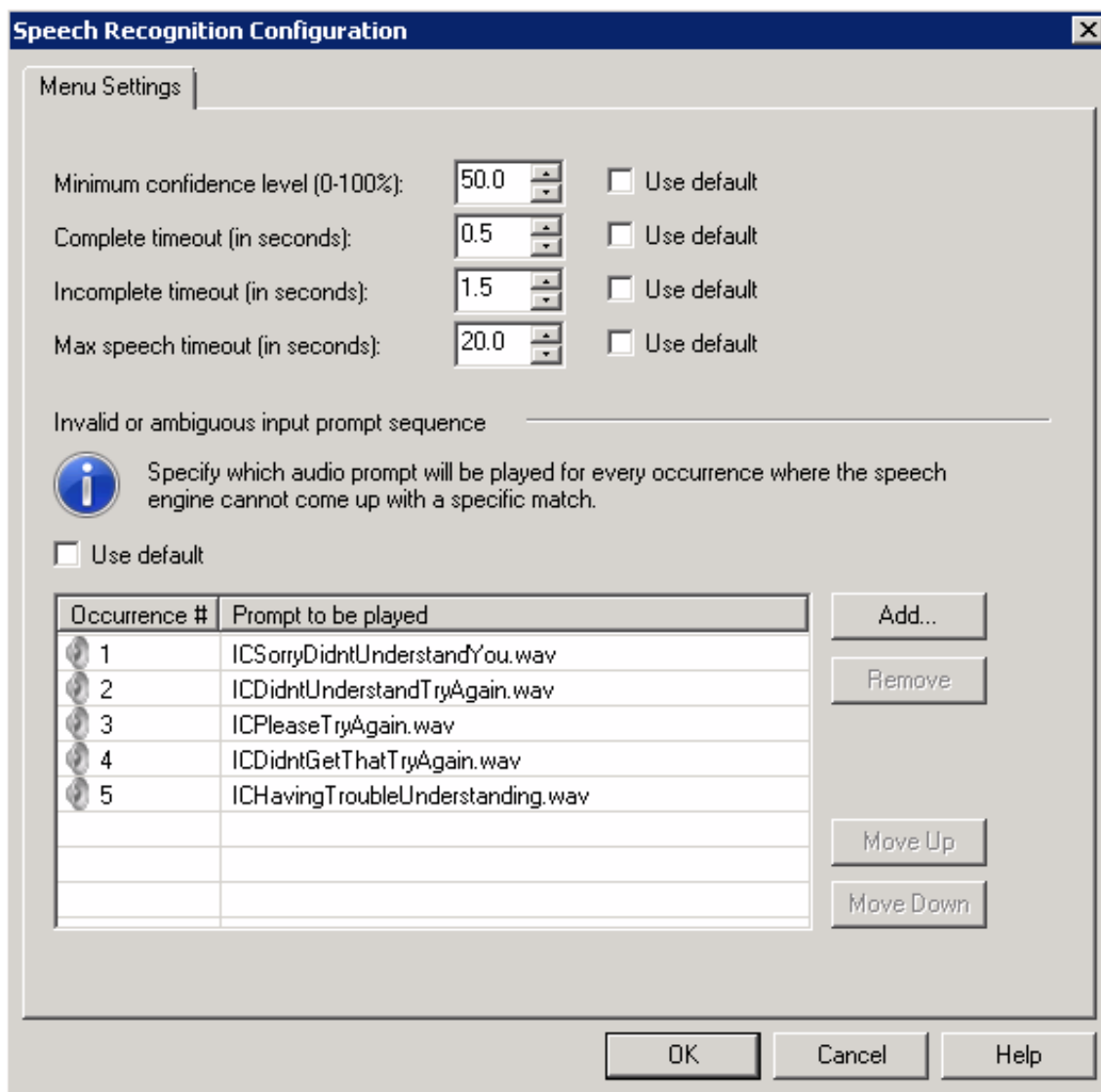

Speech Recognition Configuration dialog box for Schedules

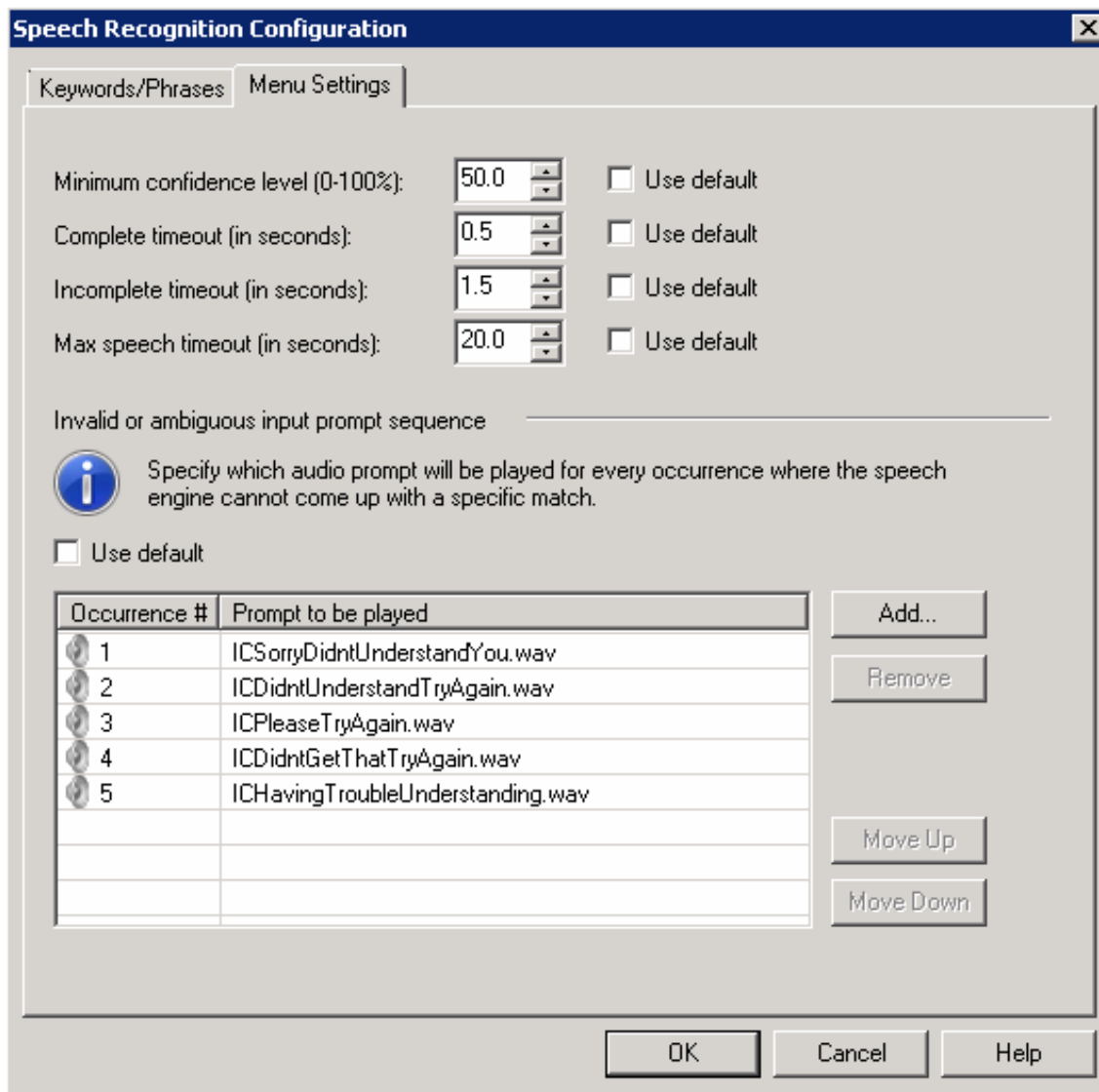

Speech Recognition Configuration dialog box for Menus

2. Select the preferred confidence and timeout levels:

- In the **Minimum confidence** level area, clear the **Use default** check box and use the up and down arrows to select the scoring percentage the phrase must receive to achieve a successful match.
- In the **Complete timeout** area, clear the **Use default** check box and use the up and down arrows to select the maximum time in seconds to wait after caller provides a valid speech input and stops talking before the system presents a positive match.
- In the **Incomplete timeout:** area, clear the **Use default** check box and use the up and down arrows to select the length of time to wait after caller stops talking and when the verbal selection is invalid before the system indicates no match is found.
- In the **Speech timeout** area, clear the **Use default** check box and use the up and down arrows to select the length of time allotted to the caller to make his or her verbal selection before the system times out and either prompts the caller to make a selection or disconnects the call.

3. Configure which messages and in what order to play them when the speech recognition engine does not recognize the caller's verbal request:

- In the **Invalid or ambiguous input prompt sequence** area, clear the **Use default** check box.
- In the Invalid or ambiguous input prompt sequence area, clear the **Use default** check box.
- To add a prompt, click **Add** and in the **Add Audio Prompt** dialog box, click the arrow at the end of the drop down list, select a prompt, and click **OK**. Or click the **Browse** button to search for the desired prompt and then click **OK**.
- To remove a prompt, select the prompt from the list and click **Remove**.
- To change the order in which the prompts are played to the caller, select the prompt and click **Move Up** or **Move Down** until the prompt is placed in the desired position.

4. To save your changes and close the **Speech Recognition Configuration** dialog box, click **OK**.

Add Speech Recognition keywords or phrases for Inbound Call Operations

For every inbound call operation, you can enter keywords and phrases a caller might use to verbally indicate the location to which they want to transfer. You can choose from a list of languages, and you can enter multiple words and phrases, particularly useful if callers might use different terminology for the same destination. For example, callers who want to reach the customer service department might say “customer service”, “customer support”, “support”, “product assistance”, and so on. You can also direct the system to immediately send the caller to the current node if the speech recognition engine matches the verbal request anywhere within the current schedule. See To configure speech recognition for inbound call operations below.

If the inbound call operation is a menu, you have the additional option to modify confidence levels, timeouts, and which messages and in what order to play them when the speech recognition engine does not recognize the caller’s verbal request. See To configure speech recognition for menu operations below.

To configure speech recognition for inbound call operations

1. Select the desired inbound call operation and click **Configure Speech Recognition** . The **Speech Recognition Configuration** dialog box for inbound call operations opens:

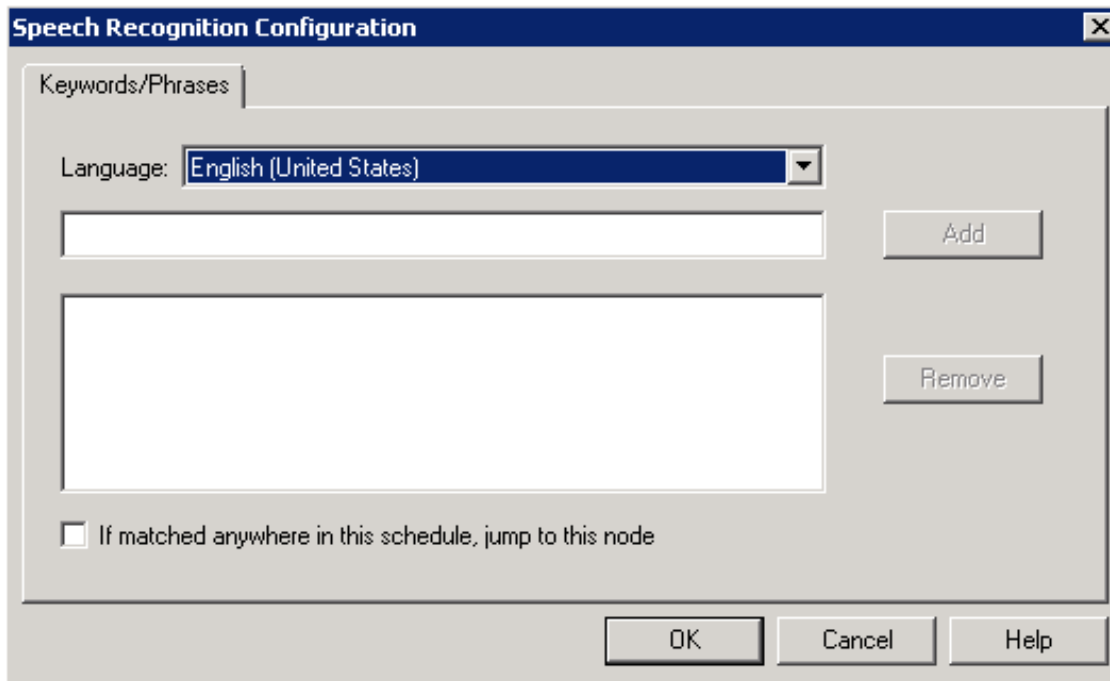

2. To change the default language for speech recognition, click the arrow at the end of the **Language** drop-down list and select the desired language.
3. To add a keyword or phrase, type the word or phrase in the blank field below the **Language** drop-down list and click **Add** or press **Enter** on the keyboard.
4. Repeat step 3 for each keyword or phrase you want to add.
5. To remove a keyword or phrase, select the word or phrase from the list and click **Remove**.
6. To immediately send the caller to the current menu operation if the speech recognition engine matches the verbal request anywhere in the current schedule, select the **If matched anywhere in this schedule, jump to this node** check box.
7. To save your changes and close the **Speech Recognition Configuration** dialog box, click **OK**.

To configure speech recognition for menu operations

1. Select the desired menu and click **Configure Speech Recognition**. The **Speech Recognition Configuration** dialog box for menu operations opens:

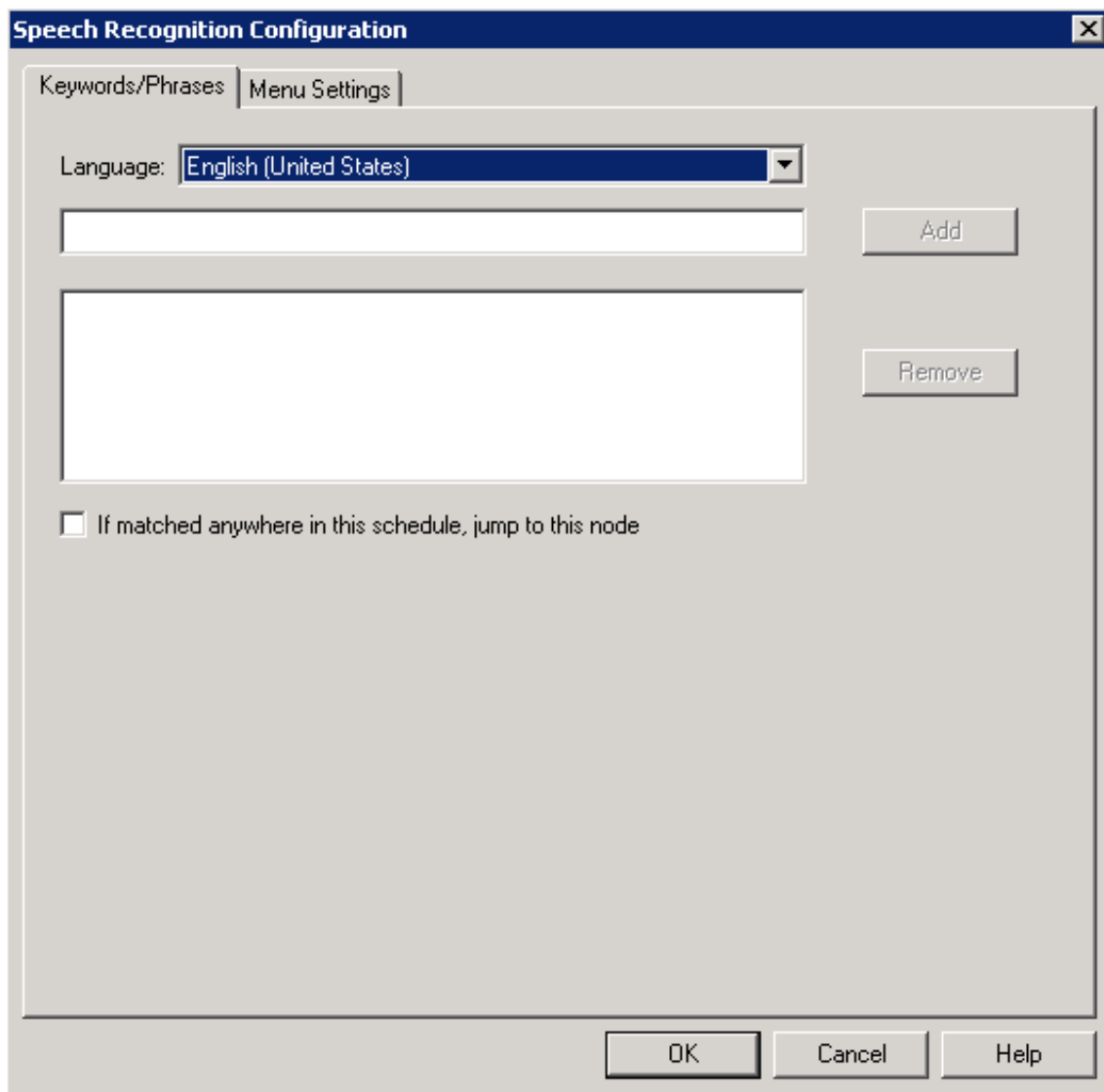

2. On the **Keywords/Phrases** tab, to change the default language for speech recognition click the arrow at the end of the **Language** drop-down list and select the desired language.
3. To add a keyword or phrase, type the word or phrase in the blank field below the **Language** drop-down list and click **Add** or press **Enter** on the keyboard.
4. Repeat step 3 for each keyword or phrase you want to add.
5. To remove a keyword or phrase, select the word or phrase from the list and click **Remove**.
6. To immediately send the caller to the current menu operation if the speech recognition engine matches the verbal request anywhere in the current schedule, select the **If matched anywhere in this schedule, jump to this node** check box.
7. To configure confidence levels, timeouts, and which messages and in what order to play them when the speech recognition engine does not recognize the caller's verbal request click the **Menu Settings** tab:

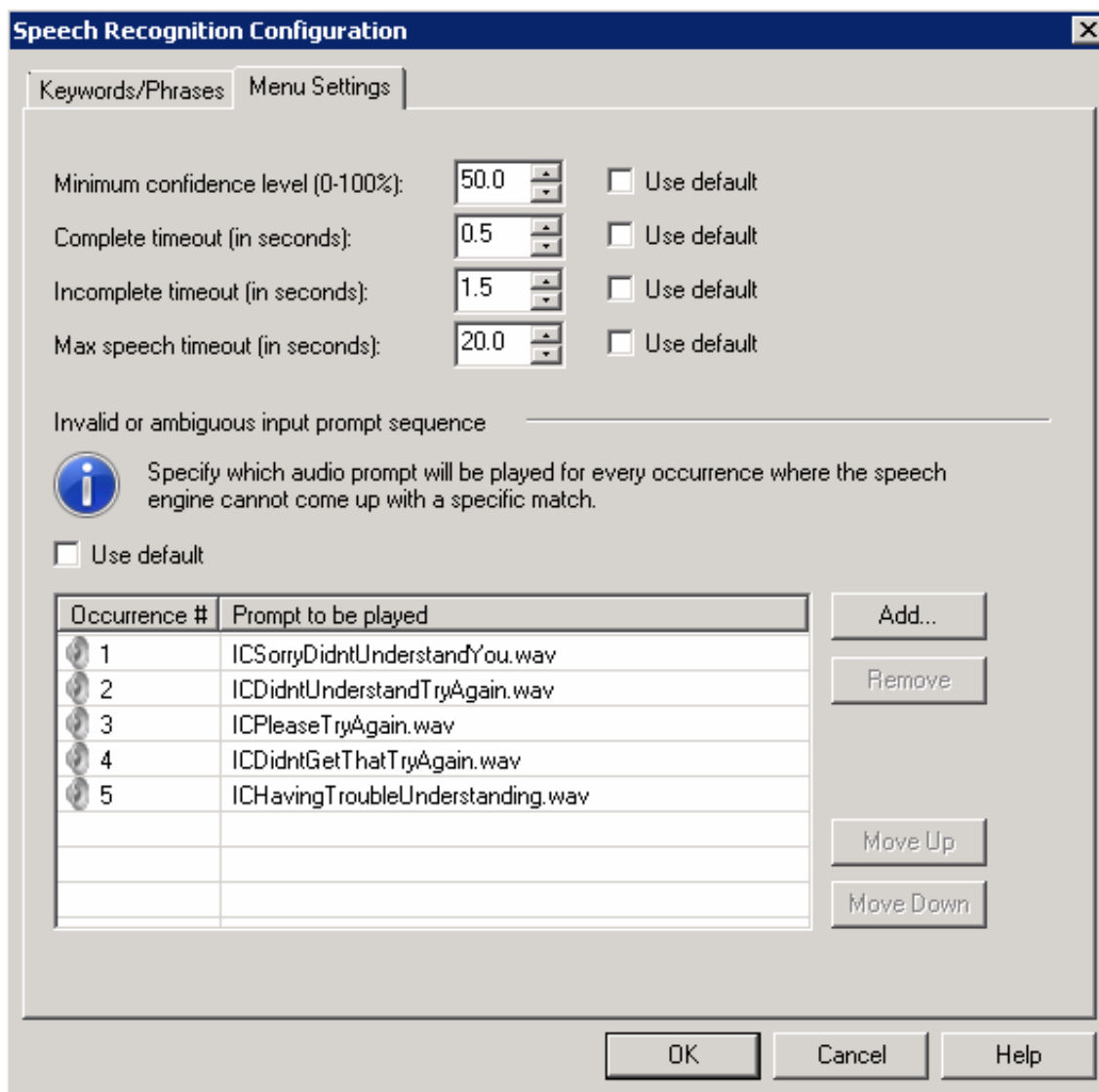

8. Select the preferred confidence and timeout levels:
 - In the **Minimum confidence** level area, clear the **Use default** check box and use the up and down arrows to select the scoring percentage the phrase must receive to achieve a successful match.
 - In the **Complete timeout** area, clear the **Use default** check box and use the up and down arrows to select the maximum time in seconds to wait after caller provides a valid speech input and stops talking before the system presents a positive match.
 - In the **Incomplete timeout**: area, clear the **Use default** check box and use the up and down arrows to select the length of time to wait after caller stops talking and when the verbal selection is invalid before the system indicates no match is found.
 - In the **Speech timeout** area, clear the **Use default** check box and use the up and down arrows to select the length of time allotted to the caller to make his or her verbal selection before the system times out and either prompts the caller to make a selection or disconnects the call.

9. Configure which messages and in what order to play them when the speech recognition engine does not recognize the caller's verbal request:
 - In the **Invalid or ambiguous input prompt sequence** area, clear the **Use default** check box.
 - To add a prompt, click **Add** and in the **Add Audio Prompt** dialog, click the arrow at the end of the drop down list, select a prompt, and click **OK**. Or click **Browse** to search for the desired prompt and then click **OK**.
 - To remove a prompt, select the prompt from the list and click **Remove**.
 - To change the order in which the prompts are played to the caller, select the prompt and click **Move Up** or **Move Down** until the prompt is placed in the desired position.

10. To save your changes and close the **Speech Recognition Configuration** dialog box, click **OK**.

Configure Remote Monitoring

Remote monitoring allows a Supervisor to continuously listen, from a remote location, calls sent to queues that the Supervisor has rights to monitor. For more information about continuous listening, see *Listen to a Call in a Queue* in the Interaction Desktop help.

To enable remote monitoring, Interaction Attendant users must make several modifications to menu nodes and handlers. Use the following procedure:

1. In Interaction Attendant, open the Profile and Schedule node from you want to enable remote monitoring login.
2. Add a new menu node, and name it *Remote Monitoring Menu*. Give it the properties shown below.

The screenshot displays the 'Inbound Call Configuration' tree on the left and the 'Remote Monitoring Menu' configuration panel on the right. The tree shows a hierarchy: Inbound Call Configuration > Default Profile > Default Schedule > Remote Monitoring Menu. The configuration panel for 'Remote Monitoring Menu' includes the following sections:

- Node Characteristics:** Name: Remote Monitoring Menu; Digit: # Pound; Active; Default Action; Enable IVR reporting; Add entry to the Interaction Log; Configure Speech Recognition...
- Audio File:** Name: <None>; Preview: [Play] [Stop]; Browse...; Record...; Details...
- Repetition:** Number of times to repeat this prompt: 0; Number of seconds to wait before repeating: 4
- Extension Dialing:** Listen for Extension Dialing; Maximum delay (seconds) for extension dialing: 2.5
- Buttons: Fax Options...

3. Add a *Subroutine Initiator* node that calls the *Remote Monitoring Menu* when the user presses pound, as shown in the figure below. Type "SystemIVRChooseQueue" in the Subroutine field.

Note—in this example, the user has chosen to have users press ## to launch the subroutine (once for the first menu, and once to launch the subroutine in the node beneath).

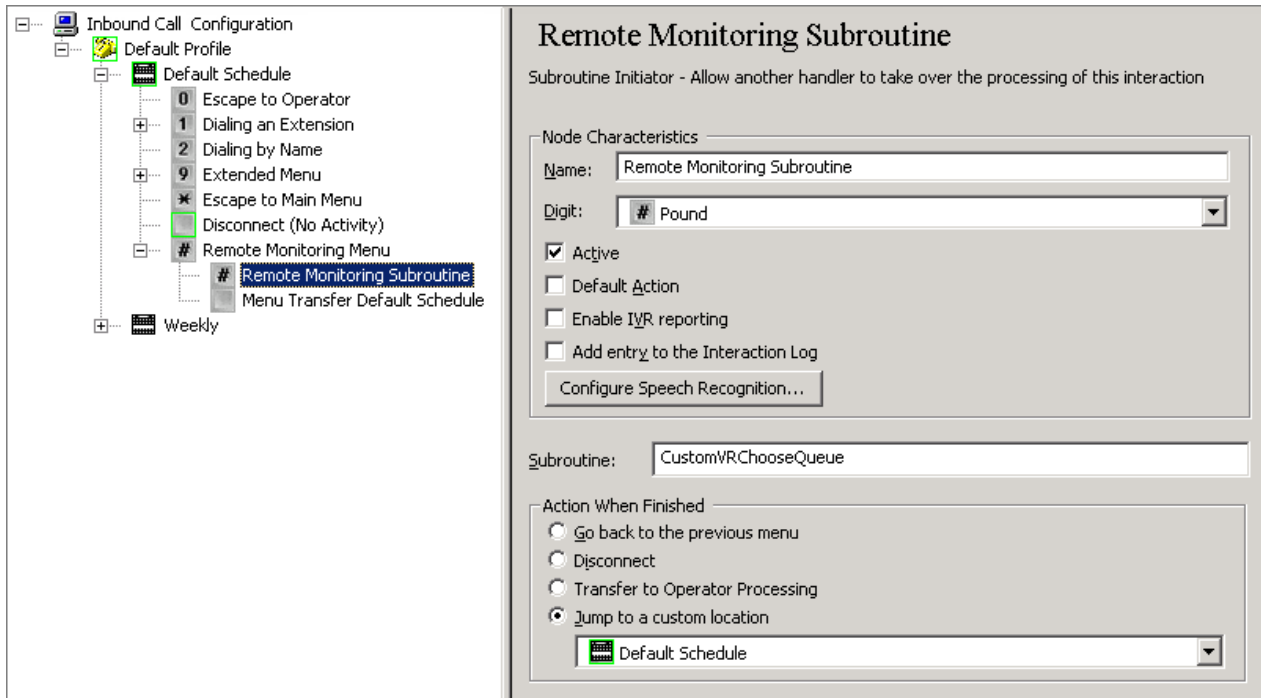

- Save and publish your changes. Then close Interaction Attendant.
- Open Interaction Designer, and edit the CustomSubroutineInitiatorRouter handler from your \IntAttHandlers directory.
- Add a new selection to step three that starts when Interaction Attendant generates a subroutine call where SubroutineName="SystemIVRChooseQueue", as shown in the following figure.

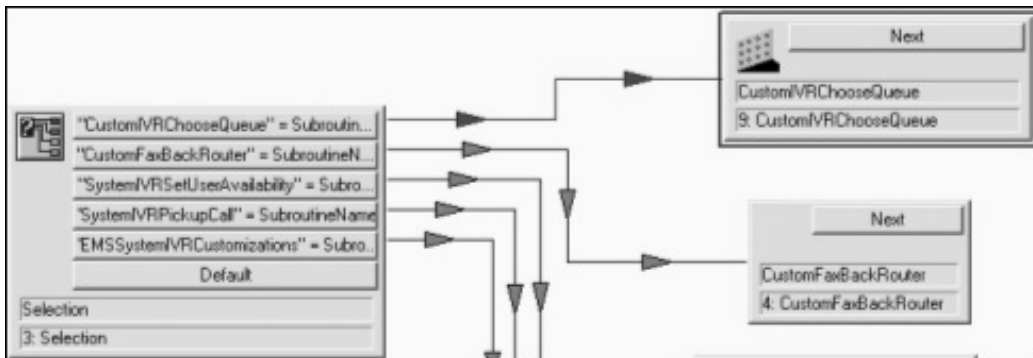

- Link that to a call to the SystemIVRChooseQueue subroutine, located in your nnHandlers directory (such a andlers), as shown in the figure below.
- In the properties for SystemIVRChooseQueue step, map the Input Call ID to the Call1 variable in CustomSubroutineInitiatorRouter. Map the Output Transferred.
- Save and publish the handler. Now when a Supervisor calls into the new menus and presses ##, the SystemIVRChooseQueue subroutine gets his or her login information and selects a queue from among those the user has rights to monitor.



Disconnect from a Server

Disconnect releases the Notifier connection between Interaction Attendant and a Customer Interaction Center server. The Notifier is a Customer Interaction Center module that acts as a communication center for all other modules. It listens for events generated by other modules and "notifies" other modules that an event has occurred. The disconnect command tells Interaction Attendant to "log out" of its session with a server. Disconnect does not close Attendant.

This option is disabled in the Edit menu unless a Server node is selected in the tree.

Disconnect removes a server form and all of its child nodes from the tree view. The option to disconnect is enabled when a server form is selected in the tree.

1. Click the server node in the tree view that you want to disconnect.
2. Issue a disconnect command using any of the following methods:
 - Pull down the *File* menu and select *Disconnect*
 - Pull down the *Edit* menu and select *Disconnect Server*
 - Press the *Disconnect Server* button () on the main toolbar
 - To disconnect from multiple servers at once, pull down the *Edit* menu and select *Manage Servers*. When the [Manage Servers dialog](#) appears, select servers to disconnect by alt-clicking entries in the list. Then press the *Disconnect* button.
3. The [Save Changes](#) dialog will appear for each server whose configuration has changed. Use pushbuttons on this dialog to publish, discard, or export configuration data. You can also cancel the disconnect operation.

Related Topics

- [Login Dialog](#)
- [Manage Servers Dialog](#)



Exit Attendant

The Exit command closes Attendant immediately if no configuration data has changed. This command is invoked using one of the following methods:

- Pull down the *File* menu and select *Exit*.
- Close the Attendant window.
- If configuration data was changed and has not been published, Attendant displays the [Save Changes](#) dialog, so that you can publish, abandon, or export configuration data, or cancel the shutdown process.

Set up Skills-based routing in Attendant

Skills-based routing can be performed by Attendant once skills have been assigned to individual users in Interaction Administrator.

1. In Attendant, add a [Transfer to a Workgroup or Station group](#) node.
2. Press the "Advanced Workgroup Settings" button.
3. Check skills that an agent must have to receive the interaction. Then press OK to dismiss the dialog.
4. From now on, calls routed to the workgroup specified in the "Group Transfer" step, will only be routed to agents in that workgroup who possess the skills you selected.

Set Up Voice Mail Distribution in Attendant

Use this procedure to configure a workgroup distribution list for voicemail distribution in Attendant:

1. In Interaction Administrator, set up a work group with no Queue.
2. Set up the work group to use a Mail box.
3. Open Attendant and create a new profile that includes a Transfer to Voice mail operation.
4. Set it as the Default action for the profile and remove any greetings.
5. Select the newly created work group from the Transfer To section.
6. Now go back to IA and change the work group back to 'No Mailbox' and remove anything in the Display name.
7. Add a new Server parameter: Workgroup Distribution List Behavior and set the value to True.
8. Add users to the workgroup and deactivate them from it.

User Interface Options

This section contains a topic for each property page and [dialog](#) in Interaction Attendant. It explains the options you can configure for server, profile, schedule, and operation nodes.

- A [server](#) node is a conceptual device that Attendant uses to organize configuration data. When you connect to a CIC server, Attendant adds a Server node for that server to the tree. Server nodes are the highest-level nodes in the tree. These nodes do not display editable information. Instead, they work like folders to organize configuration data for a CIC server.
- A [profile](#) is a collection of predefined call characteristics that Attendant compares to a call, to decide whether to select it for processing.
- A [schedule](#) stipulates when a menu can run, based upon the date, time, or special event.
- [Operations](#) are actions that Interaction Attendant performs, usually in response to a user key press. Operations are added below schedule nodes to create menus.

Servers

When you connect to a CIC server in Attendant, it adds a [Server node](#) for that server to the tree. Attendant adds a Server node automatically if it can [authenticate](#) an existing Notifier connection or your NT credentials.

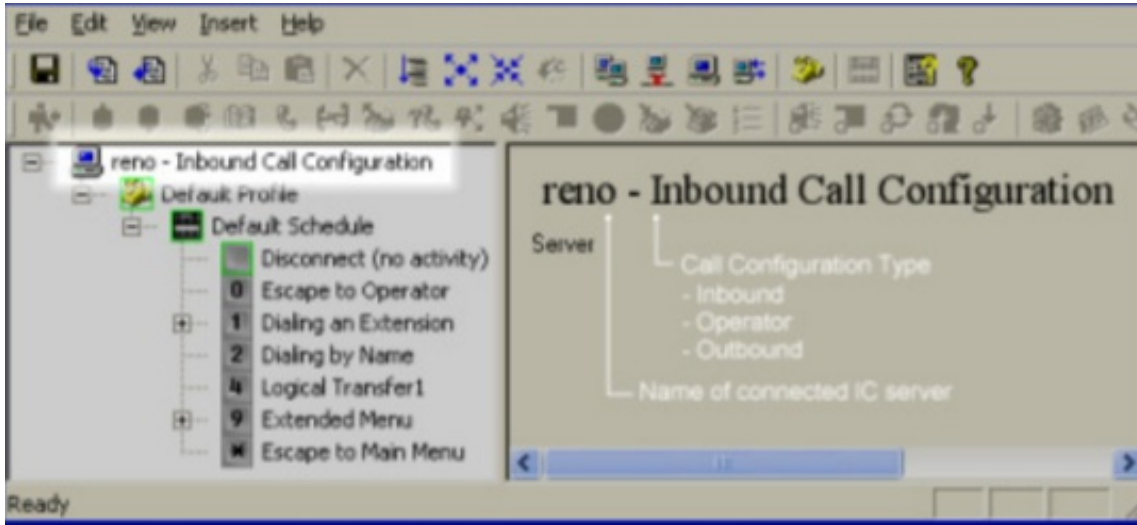

A *Server node* is a conceptual device that Attendant uses to organize configuration data. Server nodes are the highest-level nodes in the tree. These nodes do not display editable information. Instead, they work like folders to organize configuration data for a CIC server. You can quickly show or hide child nodes of a server form by double-clicking a Server icon in the tree view. Nodes below the Server node filter calls to process and select the timeliest menu to process the call.

To view nodes for a CIC server in the tree view, you must connect to the server.

If you run Interaction Attendant and the tree is empty or does not display a node for the server that you wish to configure, you must establish a connection between Interaction Attendant and the desired CIC server. See [connect to a server](#) for details.

Once you are connected to a CIC server, its schedules, profiles and menus will appear below the Server node. If you connect to more than one server, nodes for each server appear as siblings in the tree.

Server nodes are particularly helpful when Interaction Attendant is connected to several servers at one time. A Server node contains all profiles, schedules and operations that are defined for a connected server, for a given [call flow](#) (inbound, outbound, or operator).

The property sheet for a Server does not contain any configurable settings. It displays the name of the server, and the type of call configuration that is displayed in the tree.

Related Topics

- [Profiles](#)
- [Schedules](#)
- [Operations](#)
- [Dialogs](#)

Profiles

Key Concept

A *profile* is a collection of predefined characteristics that Attendant compares to an interaction, to decide whether to select the profile for processing. Profiles don't have to be very specific. They can examine a wide range of incoming characteristics. For example, inbound call profiles support wildcards and examine a combination of ANI, DNIS, and line criteria. When a profile is evaluated, the logical OR operator is used. If more than one criterion is specified, the interaction matches the profile if any of the profile's criteria are met.

Overview

When interactions such as telephone calls or emails come into Attendant, they are filtered by *profiles*. Information about the interaction is compared to predefined characteristics defined in profile nodes. The interaction is processed by the *custom* profile that matches the interaction or by a *default* profile if the interaction does not match user-defined custom profiles.

The **default profile** matches all interactions that get past custom profiles. Default profiles do not contain specific filtering criterion. **Custom profiles** contain predefined characteristics that Attendant compares to an interaction, to decide whether to select the profile for processing.

After a profile match is performed, the schedules attached to the selected profile are evaluated. Since processing logic is attached to schedules, control is passed to logic that can most appropriately process the interaction.

For example, an incoming call to the Marketing department is matched to a profile for Marketing's 800 number. Schedules attached to that profile route the call to a selected menu, based upon whether or not the call was received during working hours, at night, or during a company holiday.

Attendant analyzes interactions to select the best matching profile. This ensures that the interaction is processed by the most appropriate profile, schedule, and menu operation.

Profile Types

Attendant profiles examine criteria specific to the interaction type and call direction (inbound or outbound):

- Inbound [Call Profiles](#) examine the number dialed, Caller ID data, and the line or line group that the call is on. This can be used to filter calls based on the DNIS ("to") and ANI ("from") information on the call.
- [Operator Profiles](#) examine the user queue, workstation queue, or Attendant Profile that the call arrived on.
- [Email Profiles](#) compare the "To:", "Cc:", and "From:" fields in the Email message header to characteristics defined in the profile.
- *Outbound Profiles* examine *Call Analysis* information, since outbound calls are already connected to a contact when the call is passed to Attendant. Outbound call matching is based upon whether the call was answered by a live person, fax machine, or answering machine.

Call Analysis is a CIC process that analyzes a connection to determine if the call reached a live person, a Fax machine, an answering machine, and whether or not an agent is available to process the call. Outbound profiles use call analysis criteria to route calls based upon the type of party connected.

Call Profiles

- [Call Flow Configuration Switches](#)
- [Default Inbound Call Profile](#)
- [Custom Inbound Call Profile](#)
- [Default Outbound Call Profile](#)
- [Custom Outbound Call Profile](#)
- **Operator Profiles**
- [Default Operator Profile](#)
- [Custom Operator Profile](#)

Email Profiles

- [Email Default Profile](#)
- [Email Custom Profile](#)

Other

- [Schedules](#)
- [Operations](#)
- [Dialogs](#)

Call Profiles

When telephone calls come into Attendant, they are filtered by inbound or outbound call [profiles](#).

Inbound call profiles compare DNIS ("to") and ANI ("from") information about the call with predefined call characteristics defined in the profile, as well as the line or line group that the call is on. The call is processed by the custom profile that matches the call, or by a *default profile* that Attendant uses to process calls that don't match user-defined profiles. You can customize a default profile to play a wave file, but its filtering criteria are disabled. This insures that the default profile will match all calls that get past your custom profiles.

Outbound profiles examine *calls analysis* information, since outbound calls are already connected to a contact when the call is passed to Attendant. Outbound call matching is based upon whether the call was answered by a live person, fax machine, or answering machine.

Call Analysis is a CIC process that analyzes a connection to determine if the call reached a live person, a Fax machine, an answering machine, and whether or not an agent is available to process the call. Outbound profiles use call analysis criteria to route calls based upon the type of party connected.

Default Inbound Call Profile

Calls come into a server and then are filtered by *profiles*. Information about the call is compared to call characteristics defined in profile nodes. The call is processed by the custom profile that matches the call, or by a *default profile* that Attendant uses to process calls that don't match user-defined profiles. Interaction Attendant creates a default profile automatically for each call flow. A default profile cannot be deleted. The default profile is used when:

- It is the only profile, or...
- The characteristics of the incoming call do not match the criteria defined by any of your custom profiles.
- You can customize a default profile to play a wave file, but its filtering criterion are disabled. This ensures that the default profile always matches calls that get past your custom profiles. The following options are always disabled on a Default Profile:

Node Characteristics frame

Name

The name field is disabled so that the profile is always named *Default Profile* for easy identification.

Active check box

This check box is disabled, since default profiles are always available at runtime.

Incoming Call Selection frame

You cannot configure DNIS, ANI, Line, or Line Name values for a default profile. This is because the default profile is designed to pick up all calls that are not picked up by other profiles. However, you can create custom profiles that filter calls by examining specific [DNIS](#) or [ANI](#) values, particular line groups, or individual line names.

For information about other options on this form, see [Custom Inbound Call Profile](#).

Related Topics

- [Call Flow Configuration Switches](#)
- [Custom Inbound Call Profile](#)
- [Profiles](#)
- [Schedules](#)
- [Operations](#)
- [Dialogs](#)

Custom Inbound Call Profile

Custom inbound call profiles filter incoming calls by examining a range of incoming call characteristics. Information about each

call is compared to all inbound profiles to select the profile that matches the call. If no match is found, the call is processed by a [Default Inbound Call Profile](#).

Note: If the New Profile button () on the toolbar is greyed out, or the **New Profile** option located in the **Insert** menu is unavailable, you do not have the appropriate rights to create a new profile. See your administrator for information about obtaining your profile rights. However, if your Administrator grants you the appropriate rights to create a new profile, Interaction Attendant also automatically gives you the right to modify the profile. This feature allows you to edit any profile you create.

Node Characteristics frame

Options in this frame name the profile, establish whether or not it is active, logged, or tracked for IVR reporting purposes. Unlike [operation](#) nodes, profiles cannot be assigned a digit, since profiles are always compared to the characteristics of a call.

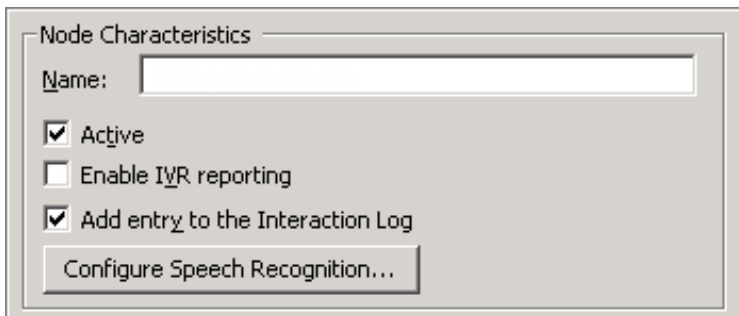

The screenshot shows a dialog box titled "Node Characteristics". It has a "Name:" label followed by a text input field. Below the input field are three checkboxes: "Active" (checked), "Enable IVR reporting" (unchecked), and "Add entry to the Interaction Log" (checked). At the bottom of the dialog is a button labeled "Configure Speech Recognition...".

Name field

The label you enter here becomes the name of the node in the tree structure.

Profile names should not contain the name of a workgroup

Please ensure that your profile name does not contain the name of a workgroup. If it does, a loop can occur, since the Find toolstep (step 162) in the InteractionAttendantEntryPoint handler checks the target workgroup name against profile names on a voicemail transfer request.

For example, a profile named "Acme - 1234" with only a Default Schedule which contains a single default action of transferring the caller to voicemail for workgroup "Acme" won't appear to work due to the find step in InteractionAttendantEntryPoint. That part of the handler compares the target workgroup to all profile names. Since workgroup name "Acme" is embedded in the profile name "Acme - 1234", the call will end up back at the profile which attempts to send it back to the workgroup's voicemail which sends it back to the profile.

This behavior is intentional and is not a bug. It is part of a workgroup transfer overload feature that forces workgroup transfers to go through an Attendant profile beginning in the same name as the workgroup. The feature is intended to allow a single place for defining ACD wait behavior no matter how the workgroup call is placed.

Active check box

By default, forms are "on", or "active", which means that Interaction Attendant will process them. If you uncheck a form's Active checkbox, the name of the node turns gray in the tree to indicate that the form is inactive. Interaction Attendant and its [handlers](#) will thereafter ignore the form and its children. Use this feature to save a configuration that you are testing. Inactive forms are invisible to callers. When a node is inactive, it appears grayed out in the tree view.

Enable IVR Reporting

This option determines whether or not reporting data will be collected when control passes through this node. Several IVR Reports summarize this information. IVR Reporting is *disabled* by default. Enable it to capture the date, time and duration of time that the call remained in the node and its children. This option is hidden when Attendant is connected to a server that does not have reporting installed. For more information about this feature, see [IVR Reporting Option](#).

Add entry to the Interaction log

When this option is enabled, information about this node is appended to the call's Interaction Log when the call enters this node. This helps track the path that a call took through Attendant. The Interaction Log is maintained for reporting purposes. See [View the Interaction Log](#) for details.

Configure Speech Recognition... button

Select the Configure Speech Recognition button to enable or disable speech recognition for the company directory, on menus, or both. By default, speech recognition is enabled for the company directory. If you choose to enable speech recognition on menus and leave it enabled for the company directory, callers will not be prompted to say the name of the person they want to reach.

To keep both options selected and direct the system to ask callers to say the name of the person or department they wish to transfer to, you must add it to the main greeting prompt. For more information on configuring speech recognition at the profile level, see [Enable Speech Recognition for a Profile](#).

Profile Greeting frame

Controls in this frame set a prompt to play when a call enters this profile. If you do not select or record a prompt using the [embedded audio controls](#), no voice prompting will occur. See [manage voice prompts](#) for details.

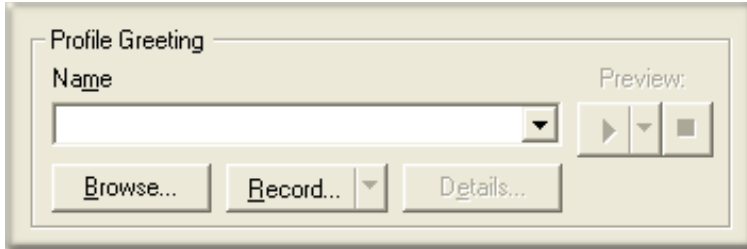

Call Processing Style button



This button opens the [Call Processing Style](#) dialog. It determines whether calls are directed to a menu (*Auto Attendant Processing*) or to a User, Station, Workgroup queue, or operator profile (*Direct to Queue Processing*). *Auto Attendant Processing* is used by default—inbound calls are directed to the menu attached to the best matching [schedule](#). In other words, *Call Processing Style* determines whether calls are directed to:

- A menu attached to a schedule in this profile. This is the default call processing behavior.
- A user, station, or workgroup queue.
- An operator profile.

Language frame

Profiles make it possible to set a language based upon the line, line group, or number that was dialed (DNIS) or by examining the telephone number that was called (ANI). For example, you can create a profile that plays voice prompts in Spanish when a specific number is called (DNIS), or when preferred Spanish-speaking customers call from known telephone numbers (ANI).



Language list box

This option affects the language used to play back voice prompts. It presents a list of languages defined on the IC server.

- If a user selects a language from the list, that language becomes the [current language](#) used to play prompts.
- If the user selects <Default>, prompts will be played using the server's [default language](#).
- If the user selects <Do Not Change>, the language that is currently set on the call won't be updated by this Profile. For example, a caller might select Spanish in a menu. If the call is routed back to this Profile somewhere down the line, the Profile would play the prompt using its language setting unless <Do Not Change> is selected. This option tells the Profile not to change the language set by another node, if the call returns to the profile.

Transfer Target option

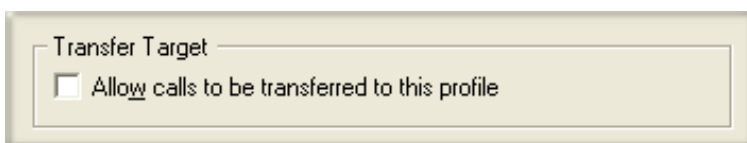

Allow calls to be transferred to this profile

This checkbox determines whether or not Interaction Supervisor or Interaction Client users can transfer calls to this inbound Attendant profile. Rather than open up the entire Attendant tree when calls are transferred, calls must be transferred into profiles, just like inbound calls. The call is then processed according to the profile's settings.

If this box is checked, then users see the profile as a potential transfer target. Otherwise the profile is only available to inbound calls. Profiles are not targeted by default.

This feature allows operators to send calls into queues using Attendant, ensuring that both inbound callers and callers transferred into a queue have the same in-queue experience. For example, if there are customer service menus in Interaction Attendant before a call is sent to that workgroup's queue, users can intuitively transfer callers to the Customer Service Profile rather than directly into the queue. This way, callers will hear the same prompts and menus as other callers for that group.

This feature is limited to inbound call profiles. Users cannot transfer calls to operator profiles (except by transferring the calls to the operator) or to outbound profiles.

Incoming Call Selection frame

This section of the page defines call characteristics that will be compared to the characteristics of an incoming call to determine whether it should be processed by this profile. A Custom Inbound Call Profile can filter calls based upon [DNIS](#), [ANI](#), line, or line group information that is associated with each call.

You can filter on any or all of these criteria at the same time. If you check a checkbox, you must enter data in the associated field. If you don't, a red exclamation point (!) will appear next to the profile in the tree. If you move the mouse pointer over this node, tool-tip help will appear to explain the error.

Incoming Call Selection

Enter phone numbers and/or ranges of numbers separated by commas. Do not use any formatting characters when entering a phone number. For further explanation of formatting, click the "Formatting Help" button below.

Use this profile to process incoming calls with any of the following DNIS (the number the caller dialed) values:

Use this profile to process incoming calls with any of the following ANI (the number from which the the caller is calling) values:

Use this profile to process incoming calls which arrived from this line or line group:

Formatting Help

You can filter incoming calls based upon any combination of DNIS, ANI, or Line criteria. At runtime, these are evaluated using the logical AND operator. If more than one criterion is specified, the interaction matches the profile of all of the profile's criteria are met. Telephone numbers must be entered without formatting, and may contain wildcards—see [formatting help](#).

ANI, DNIS, line, and line group information is evaluated before calls are answered. Thereafter, that information is ignored. For example, ANI/DNIS data is not evaluated when an error handler transfers a call to the menu associated with a profile. If an Attendant profile is configured to route a call based on ANI, and if in the rare case that the DNIS numbers matches the ANI as well, the DNIS routing will take precedence over the ANI routing rule.

The ANI and DNIS numbers sent by your phone company will usually contain between 4 and 11 digits. The DNIS string you receive may contain more or fewer digits than the ANI string. Please consult with your System Administrator or Phone Company to find out how many digits to expect for your DNIS and ANI strings.

Use this profile to process incoming calls with any of the following DNIS (the number the caller dialed) values

Dialed Number Identification Service (DNIS) is a feature of digital T-1 and ISDN lines (e.g. 800 and 900 lines). DNIS provides

the telephone number that the caller dialed. Knowing the dialed number allows Interaction Attendant to perform unique processing on the call, such as playing special messages or offering alternate menu choices.

Suppose, for example, that a company offers two levels of technical support, silver and gold. Silver members call 555-1111, and Gold members call 555-2222. In Interaction Attendant you would create a profile for each number. When callers dial 555-2222, their call is processed by profile for gold support. When callers dial 555-1111, their call is processed by the profile for the silver technical support.

If your company's phone lines are configured to accept DNIS, you can configure a profile to play for a call dialed to that number. Ask your CIC administrator if your company's phone lines accept DNIS information; if so, he or she can provide a list of DNIS numbers. You can then create a profile for one or more of these DNIS entries. If the number dialed does not match any of your DNIS profiles, the default profile is played. You can assign DNIS or line name settings to each profile (except the default profile). You can assign more than one DNIS value to a profile. Separate individual values with a comma (8723000, 8723500) and specify a range with a hyphen (8723000-8723005). This is similar to specifying a page range when printing in most Windows application.

If a call is transferred using Attendant extension dialing, then the call will be routed using the following order of precedence to resolve duplicate extensions and/or DNIS numbers in custom profiles:

User -> Workgroup -> Station -> Stationgroup -> Profile

Use this profile to process incoming calls with any of the following ANI (the number from which the caller is calling) values

Automatic Number Identification (ANI) provides the caller's telephone number. ANI is often called Caller ID. By creating profiles for ANI values, you can:

- Provide tailored menus to preferred clients or companies.
- Route calls from employees to special menus.

Use this profile to process incoming calls which arrived from this line or line group

You can also filter based upon the line or line group that the incoming call came in on. This list box displays lines and line groups that are defined for the current server.

Handlers perform DNIS Lookup for Attendant

This information is for advanced CIC users who are familiar with *handlers*—small programs in CIC that carry out tasks for Attendant and other systems. The IntAttIncomingCall handler looks to see if the DNIS information for a call is associated with a profile. If the DNIS is matched to a profile, the call is placed on that profile. If one is not found, the IntAttIncomingCall [handler](#) looks for a matching line name. Failing that, the call is placed on the default profile in the currently scheduled menu. If you want modify the DNIS value before it is evaluated by Interaction Attendant, CustomGetDNIS is the customization point in which you should make the changes.

Caution—Changing IntAttIncomingCall can cause Interaction Attendant to function incorrectly or not at all. Any customizations you make to DNIS modification should be created in the CustomGetDnis handler.

Formatting Help button



Telephone numbers must be entered without formatting. When you press this button, you are provided with tips for using wildcards and for entering ranges. See [Formatting Help dialog](#).

Formatting DNIS/ANI routing for SIP

In a SIP/HMP environment, special care must be taken when formatting wildcards for ANI and DNIS profiles. Matches can fail when wildcards are used, since Wildcard matching compares STRINGS and allows for ? to match.

For example, 666666? does not match sip:6666666@domain.com, since the range matching looks at 6666666 part of the DNIS and treats it as a number. The Wildcard does not. In order to work correctly, the exact string needs to be entered in the DNIS routing:

sip:666????@xxx.x.xx:5060 or sip:666????@domain.com:5060

Range matching always works if you specify an exact telephone number (e.g. 4445555).

Incoming call criteria is analyzed to find the best match

To determine which profile best matches incoming call criteria, Interaction Attendant analyzes custom profiles to find the best match. Suppose, for example, that you create a profile for All 800 numbers, and another for calls to one Customer Support

number. The example below illustrates how the profiles might look:

The image shows two side-by-side profile configuration forms. The left form is titled "800 Customer Support" and the right form is titled "All 800 Numbers". Both forms have a "Node Characteristics" section with a "Name" field and an "Active" checkbox. The "Incoming Call Selection" section contains instructions and a checkbox to use the profile for incoming calls, with a field for DNIS values.

Profile Name	Node Characteristics Name	DNIS Values
800 Customer Support	800 Customer Support	8004328321
All 800 Numbers	All 800 Numbers	800???????

When 800-432-8321 is called, the profile named "800 Customer Support" is a more specific match than "All 800 Numbers", so the profile for the specific number would be used when an incoming call comes in on that line.

Speech Recognition frame

Disable Speech Recognition check box

Attendant Profiles are speech-enabled by default. This option disables the default dial-by-name prompting with speech recognition, to prevent Attendant from barging in to prompt for a name to dial. When checked, the Attendant profile does not prompt for ASR input.

This option is unchecked by default, so that ASR speech recognition is enabled, and prompting occurs. Internally, this option sets a profile node attribute named "DisableSpeechRec" with a value of "Yes" or "No". If the attribute is not present (as in existing profile configurations), the profile defaults to unchecked so that prompting occurs.

For more information about speech recognition, refer to these Technical Reference documents in the PureConnect Documentation Library:

- Getting Started with Speech Recognition in CIC
- Installing and Configuring ASR Technology

Default Outbound Call Profile

Outbound calls can be transferred to Attendant so that the connected party can interact with auto-attendant menus. Outbound call flows can route calls to users or groups, and may perform other operations (such as surveys) without requiring handler customization. When Attendant receives an outbound call, it is already connected to a contact.

For example, a doctor's office might set up an outbound call flow to automate appointment reminder processing. Or a contact center might use Interaction Dialer to contact thousands of customers, and pass each call to Interaction Attendant without agent intervention.

Synergy with Interaction Dialer

Attendant and Interaction Dialer work cooperatively as follows:

1. Dialer places the call and analyzes it to figure out what the call is connected to (live party, answering machine, etc.)
2. Dialer looks at its configuration and determines, based on the campaign that generated the call, which outbound profile should take the call.
3. Dialer places two attributes on the call; a call analysis code (SIT, Fax, connected, answering machine, busy, etc.), and the name of the Attendant profile that should process the call when it is passed to Attendant.
4. When Attendant receives the call, it routes it to the profile identified by the call attribute, and then routes the call to an outbound schedule based on the call analysis code.
5. Standard Attendant routing is used after that.
6. If the call passes through a [Disposition Interaction Dialer Call](#) node, a custom finish code is set on the call for reporting purposes.
7. When the call ends, its disposition and reason codes are returned to Dialer.

Disabled Options

You can customize a Default Outbound Call Profile to play a wave file, but the you cannot rename this node. Its Name field is disabled so that the profile is always named *Default Outbound Profile* for easy identification. Likewise, its *Active* check box is disabled to insure that the profile is always available at runtime.

Configurable Options

See [Custom Outbound Call Profile](#).

Related Topics

- [Call Flow Configuration Switches](#)
- [Profiles](#)
- [Schedules](#)
- [Operations](#)
- [Dialogs](#)

Custom Outbound Call Profile

Outbound profiles establish a configuration to process outbound calls—calls that have been placed and which are already connected. For example, an Outbound call flow might process a call that Interaction Dialer placed to someone in a contact list. You can connect Custom Outbound Call Schedules to an outbound profile, and then use call analysis information in the schedule to route the call to menus that are tailored to interact with live persons, answering machines, or Fax machines.

If the Outbound profile is configured for Direct-to-Queue processing, the connected call is routed to a user, station, or workgroup queue, or to any outbound profile defined for that server. Outbound call flows add a new dimension of call processing capability to the CIC environment.

Note: If the New Profile button () on the toolbar is greyed out, or the New Profile option located in the Insert menu is unavailable, you do not have the appropriate rights to create a new profile. See your administrator for information about obtaining your profile rights. However, if your Administrator grants you the appropriate rights to create a new profile, Interaction Attendant also automatically gives you the right to modify the profile. This feature allows you to edit any profile you create.

Node Characteristics frame

Options in this frame name the profile, establish whether or not it is active, logged, or tracked for IVR reporting purposes. Unlike [operation](#) nodes, profiles cannot be assigned a digit, since profiles are always compared to the characteristics of a call.

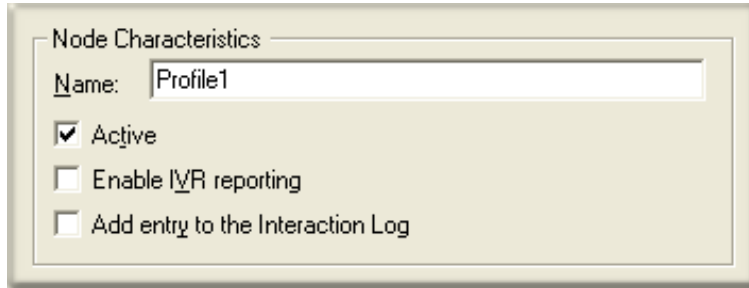

Name field

The label you enter here becomes the name of the node in the tree structure.

Active check box

By default, forms are "on", or "active", which means that Interaction Attendant will process them. If you uncheck a form's Active check box, the name of the node turns gray in the tree to indicate that the form is inactive. Interaction Attendant and its [handlers](#) will thereafter ignore the form and its children. Use this feature to save a configuration that you are testing. Inactive forms are invisible to callers. When a node is inactive, it appears grayed out in the tree view.

Enable IVR Reporting

This option determines whether or not reporting data will be collected when control passes through this node. Several IVR Reports summarize this information. IVR Reporting is *disabled* by default. Enable it to capture the date, time and duration of time that the call remained in the node and its children. This option is hidden when Attendant is connected to a server that does not have reporting installed. For more information about this feature, see [IVR Reporting Option](#).

Add entry to the Interaction log

When this option is enabled, information about this node is appended to the call's Interaction Log when the call enters this node. This helps track the path that a call took through Attendant. The Interaction Log is maintained for reporting purposes. See [View the Interaction Log](#) for details.

Profile Greeting frame

Controls in this frame set a prompt to play when a call enters this profile. If you do not select or record a prompt using the [embedded audio controls](#), no voice prompting will occur. See [manage voice prompts](#) for details.

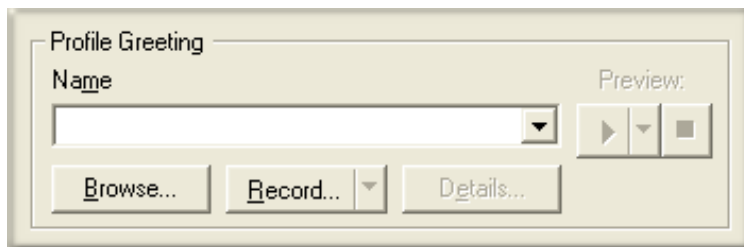

Call Processing Style button

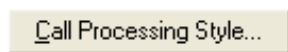

This button opens the [Call Processing Style](#) dialog. It determines whether calls are directed to a menu (*Auto Attendant Processing*) or to a User, Station, Workgroup queue, or operator profile (*Direct to Queue Processing*). *Auto Attendant Processing* is used by default—inbound calls are directed to the menu attached to the best matching [schedule](#). In other words, *Call Processing Style* determines whether calls are directed to:

- A menu attached to a schedule in this profile. This is the default call processing behavior.
- A user, station, or workgroup queue.
- An operator profile.

Language frame

This option affects the language used to play back voice prompts. It presents a list of languages defined on the CIC server.



Language list box

- If a user selects a language from the list, that language becomes the [current language](#) used to play prompts.
- If the user selects <Default>, prompts will be played using the server's [default language](#).
- If the user selects <Do Not Change>, the language that is currently set on the call won't be updated by this Profile. For example, a caller might select Spanish in a menu. If the call is routed back to this Profile somewhere down the line, the Profile would play the prompt using its language setting unless <Do Not Change> is selected. This option tells the Profile not to change the language set by another node, if the call returns to the profile.

Related Topics

- [Call Flow Configuration Switches](#)
- [Default Outbound Call Profile](#)
- [Disposition Interaction Dialer Call](#)
- [Profiles](#)
- [Schedules](#)
- [Operations](#)
- [Dialogs](#)

Operator Profiles

Calls to the operator are filtered by Operator Profiles that examine the user queue, workstation queue, or Attendant Profile that the call arrived on. Attendant supports two types of Operator profiles:

- Attendant compares the characteristics of a call to the operator with [Custom Operator Profiles](#) to determine which profile should process the call. Filtering is performed by comparing the user queue, workgroup queue, or Attendant Profile that the call came from with characteristics stored in the profile.
- [Default Operator Profiles](#) select calls that do not match Custom Operator profiles.

Default Operator Profile

Calls to the operator are filtered by *operator profiles*. Information about the call is compared to call characteristics defined in operator profile nodes. The call is processed by the custom profile that matches the call, or by a *default operator profile* that Attendant uses to process calls that don't match user-defined profiles. Interaction Attendant creates a default profile automatically for each call flow. A default profile cannot be deleted. The default profile is used when:

- It is the only profile, or...
- The characteristics of the incoming call do not match the criteria defined by any of your custom profiles.
- You can customize a default operator profile to play a different wave file, but its incoming call selection filtering criterion are disabled. This insures that the default operator profile always matches calls that get past custom operator profiles. The following options are always disabled on a Default Operator Profile:

Name

The name field is disabled so that the profile is always named *Default Profile* for easy identification.

Active check box

This check box is disabled, since default profiles are always available at runtime.

Incoming Call Selection options (user, workgroup, Attendant Profiles)

Incoming call section options that screen calls based upon originating user queue, workgroup queue, or Attendant Profile are disabled. You can create custom operator profiles that filter calls by examine these criteria, however.

For information about other options on this form, see [Custom Operator Profile](#).

Related Topics

- [Call Flow Configuration Switches](#)
- [Custom Operator Profile](#)
- [Profiles](#)
- [Schedules](#)
- [Operations](#)
- [Dialogs](#)

Custom Operator Profile

Custom Operator profiles screen calls to the operator by examining the originating queue or Attendant Profile. Information about each call is compared to all operator profiles to select the profile that matches the call. If no match is found, the call is processed by a [default operator profile](#).

Note: If the New Profile button () on the toolbar is greyed out, or the New Profile option located in the Insert menu is unavailable, you do not have the appropriate rights to create a new profile. See your administrator for information about obtaining your profile rights. However, if your Administrator grants you the appropriate rights to create a new profile, Interaction Attendant also automatically gives you the right to modify the profile. This feature allows you to edit any profile you create.

Node Characteristics frame

Options in this frame name the profile, establish whether or not it is active, logged, or tracked for IVR reporting purposes. Unlike [operation](#) nodes, profiles cannot be assigned a digit, since profiles are always compared to the characteristics of a call.

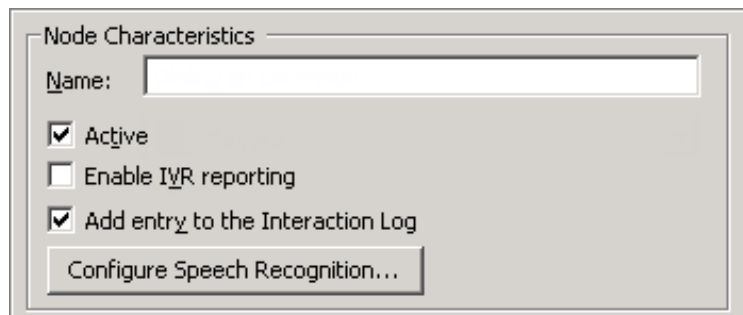

The screenshot shows a dialog box titled "Node Characteristics". It contains a "Name:" text field. Below it are three checkboxes: "Active" (checked), "Enable IVR reporting" (unchecked), and "Add entry to the Interaction Log" (checked). At the bottom, there is a button labeled "Configure Speech Recognition...".

Name field

The label you enter here becomes the name of the node in the tree structure.

Active check box

By default, forms are "on", or "active", which means that Interaction Attendant will process them. If you uncheck a form's Active check box, the name of the node turns gray in the tree to indicate that the form is inactive. Interaction Attendant and its [handlers](#) will thereafter ignore the form and its children. Use this feature to save a configuration that you are testing. Inactive forms are invisible to callers. When a node is inactive, it appears grayed out in the tree view.

Enable IVR Reporting

This option determines whether or not reporting data will be collected when control passes through this node. Several IVR Reports summarize this information. IVR Reporting is *disabled* by default. Enable it to capture the date, time and duration of time that the call remained in the node and its children. This option is hidden when Attendant is connected to a server that does not have reporting installed. For more information about this feature, see [IVR Reporting Option](#).

Add entry to the Interaction log

When this option is enabled, information about this node is appended to the call's Interaction Log when the call enters this node. This helps track the path that a call took through Attendant. The Interaction Log is maintained for reporting purposes. See [View the Interaction Log](#) for details.

Configure Speech Recognition... button

Select the **Configure Speech Recognition** button to enable or disable speech recognition for the company directory, on menus, or both. By default, speech recognition is enabled for the company directory. If you choose to enable speech recognition on menus and leave it enabled for the company directory, callers will not be prompted to say the name of the person they want to reach.

To keep both options selected and direct the system to ask callers to say the name of the person or department they wish to transfer to, you must add it to the main greeting prompt. For more information on configuring speech recognition at the profile level, see [Enable Speech Recognition for a Profile](#).

Profile Greeting

These [embedded audio controls](#) manage the optional greeting that plays when a call enters this profile. See [manage voice prompts](#) for more exhaustive information.

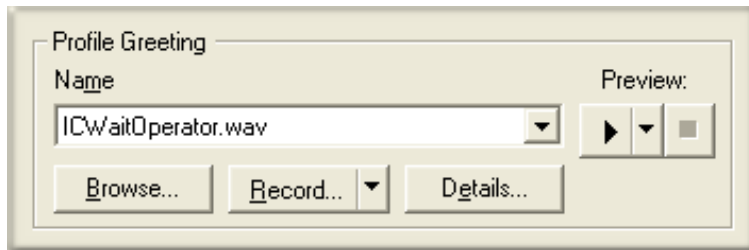

Call Processing Style button

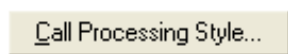

This button opens the [Call Processing Style](#) dialog. It determines whether calls are directed to a menu (*Auto Attendant Processing*) or to a User, Station, Workgroup queue, or operator profile (*Direct to Queue Processing*). *Auto Attendant Processing* is used by default—operator calls are directed to the menu attached to the best matching [operator schedule](#). In other words, *Call Processing Style* determines whether calls are directed to:

- A menu attached to a schedule in this profile. This is the default call processing behavior.
- A user, station, or workgroup queue.
- An inbound profile.

Language frame

Profiles can set a language based upon incoming call characteristics of some sort. The *language* list box affects the language used to play back voice prompts. It presents a list of languages defined on the CIC server, and some special options.



Language list box

If a user selects a language from the list, that language becomes the [current language](#) used to play prompts.

If a user selects <Default>, prompts will be played using the server's [default language](#).

If a user selects <Do Not Change>, the language that is currently set on the call won't be updated by this Profile. For example, a caller might select Spanish in a menu. If the call is routed back to this Profile somewhere down the line, the Profile would play the prompt using its language setting unless <Do Not Change> is selected. This option tells the Profile not to change the language set by another node, if the call returns to the profile.

Incoming Call Selection frame

This section of the page defines call characteristics that will be compared to the characteristics of an incoming call to determine whether it should be processed by this profile. A custom operator profile can filter calls based upon the user queue, workgroup queue, or Attendant Profile that the call came from.

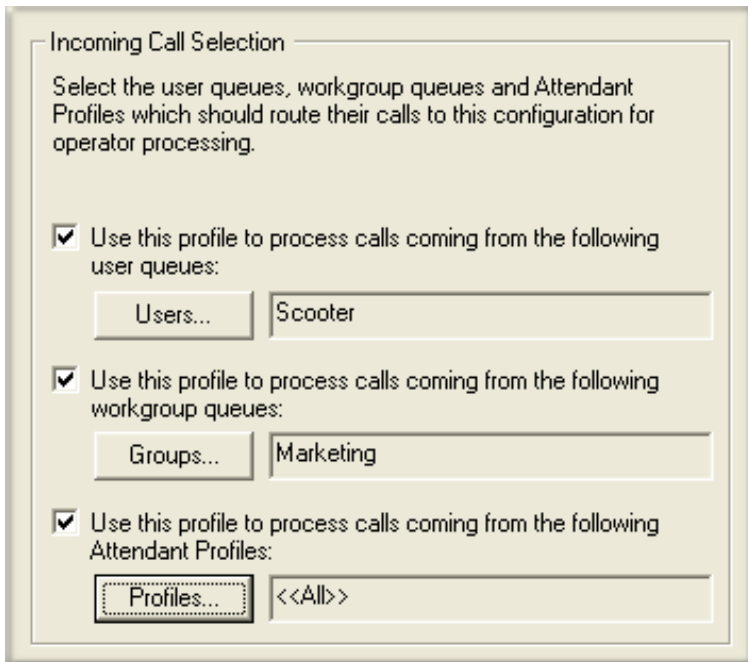

You can filter on any or all of these criteria at the same time. If you check a check box, you must configure its associated field. If you don't, a red exclamation point (!) will appear next to the profile in the tree. If you move the mouse pointer over the node, tool-tip help will appear to explain the error. At runtime, your choices are evaluated using the logical OR operator. If more than one criterion is specified, the interaction matches the profile if [any](#) of the profile's criteria are met.

Use this profile to process calls coming from the following user queues check box

Check this box to process calls that originate from user queues. When the Users button is pressed, a dialog lists the names of user queues defined on the server.

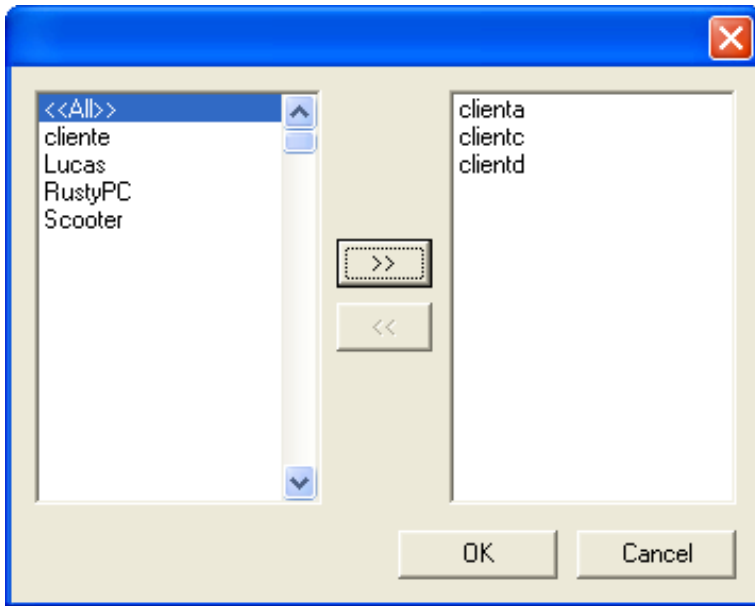

Select user queues in the list on the left. Click and drag to make contiguous selections, or ctrl-click to make discontinuous selections. Then press >> to add your selections to the list on the right. It contains the names of queues that you have selected. Items can be removed from the rightmost list by selecting them and pressing <<. To quickly select all user queues (present and future), add <<All>> to the right side list.

When you are finished, press OK to dismiss the dialog. The names of the first few selections are displayed in the read-only field. If you press Cancel, the dialog is closed without saving changes.

Use this profile to process calls coming from the following workgroup queues check box

Check this box to process calls that originate from workgroup queues. When the Groups button is pressed, a dialog lists the names of workgroup queues defined on the server.

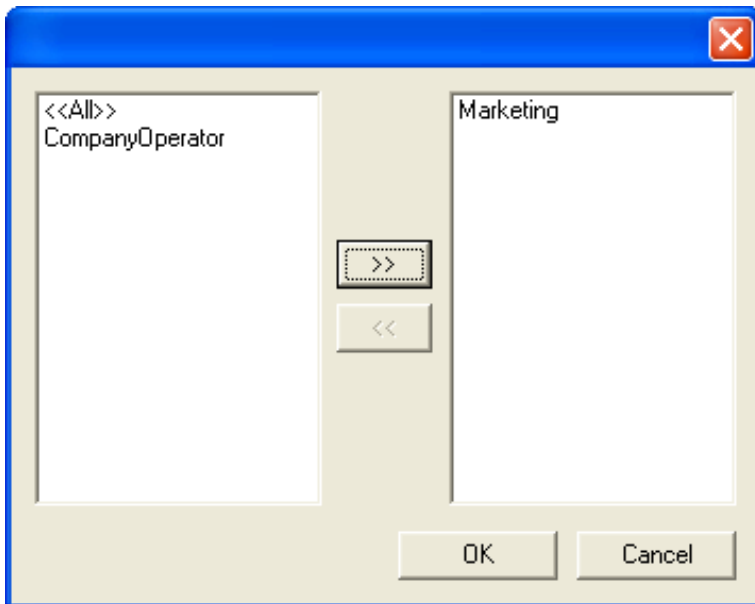

Select workgroup queues in the list on the left. Click and drag to make contiguous selections, or ctrl-click to make discontinuous selections. Then press >> to add your selections to the list on the right. It contains the names of queues that you have selected. Items can be removed from the rightmost list by selecting them and pressing <<. To quickly select all workgroup queues (present and future), add <<All>> to the right side list.

When you are finished, press OK to dismiss the dialog. The names of the first few selections are displayed in the read-only field. If you press Cancel, the dialog is closed without saving changes.

Use this profile to process calls coming from the following Attendant Profiles check box

Check this box to process calls that originate from an Attendant profile. When the Profiles button is pressed, a dialog lists the names of Profiles defined on this server.

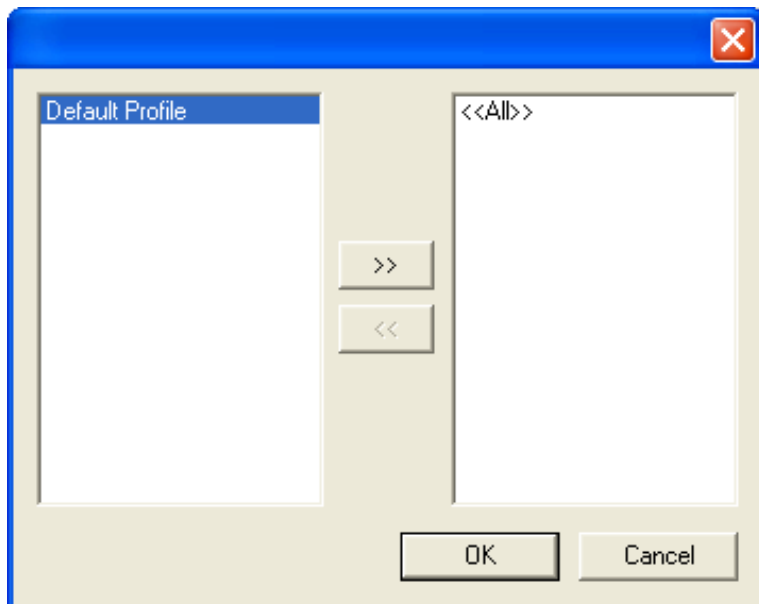

Select profiles by name in the list on the left. Click and drag to make contiguous selections, or ctrl-click to make discontinuous selections. Then press >> to add your selections to the list on the right. It contains the names of profiles that you have selected. Items can be removed from the rightmost list by selecting them and pressing <<. To quickly select all profiles (present and future), add <<All>> to the right side list.

When you are finished, press OK to dismiss the dialog. The names of the first few selections are displayed in the read-only field. If you press Cancel, the dialog is closed without saving changes.

Related Topics

- [Call Flow Configuration Switches](#)
- [Default Operator Profile](#)
- [Profiles](#)
- [Schedules](#)
- [Operations](#)
- [Dialogs](#)

Email Profiles

A *profile* is a collection of predefined characteristics that Attendant compares to an interaction, to decide whether to select the profile for processing. Email profiles examine address information in an email message. Attendant supports two types of email profiles:

- [Custom Email profiles](#) analyze messages from specific mailboxes. Filtering is performed by examining "From:" fields in each message.
- [Default Email profiles](#) select messages that do not match custom email profiles. Since default email profiles do not examine fields in a message, or allow selection of mailboxes to monitor, they catch messages that do not match custom profiles.
- Attendant's Email handlers monitor the mailboxes specified by non-default profiles. When a new message enters one of those mailboxes, the handlers find the best-matching profile for the email interaction. The "best" match is the most specific match among all of the profiles that are configured to monitor the mailbox from which the email was retrieved. If none of the profiles match the email, then the message is handled by the Default Email Profile.

Email Default Profile

The Default Email Profile catches messages that get past your [custom Email profiles](#). Most criterion are disabled, since default Email profiles do not examine fields in a message, or allow selection of mailboxes to monitor.

Attendant's Email handlers monitor all the mailboxes specified by the non-default profiles. When a new message enters one of those mailboxes, the handlers find the best-matching profile for the Email interaction. The "best" match is the most specific match among all of the profiles that are configured to monitor the mailbox from which the Email was retrieved. If none of the custom profiles match the Email, then the message is handled by the Email Default Profile.

Node Characteristics frame

Options in this frame name the node, and establish whether or not it is active, logged, or tracked for reporting purposes.

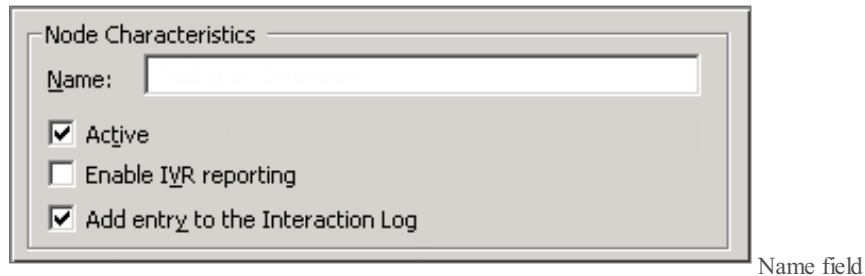

The label you enter here becomes the name of the node in the tree structure.

Active check box

By default, forms are "on", or "active", which means that Interaction Attendant will process them. If you uncheck a form's Active check box, the name of the node turns gray in the tree to indicate that the form is inactive. Interaction Attendant and its [handlers](#) will thereafter ignore the form and its children. Use this feature to save a configuration that you are testing. Inactive forms are invisible to callers. When a node is inactive, it appears grayed out in the tree view.

Enable IVR Reporting

This option determines whether or not reporting data will be collected when control passes through this node. Several IVR Reports summarize this information. IVR Reporting is *disabled* by default. Enable it to capture the date, time and duration of time that the call remained in the node and its children. This option is hidden when Attendant is connected to a server that does not have reporting installed. For more information about this feature, see [IVR Reporting Option](#).

Add entry to the Interaction log

When this option is enabled, information about this node is appended to the call's Interaction Log when the call enters this node. This helps track the path that a call took through Attendant. The Interaction Log is maintained for reporting purposes. See [View the Interaction Log](#) for details.

Related Topics

- [Email Profiles](#)
- [Email Schedules](#)
- [Email Operations](#)

Email Custom Profile

Custom email profiles filter messages from specific mailboxes by comparing static values stored in the profile with "To:", "Cc:", and "From:" fields in each message. These comparisons select the profile that best matches the message. If no match is found, the call is processed by a [Default Email Profile](#).

Note: If the New Profile button () on the toolbar is greyed out, or the New Profile option located in the Insert menu is unavailable, you do not have the appropriate rights to create a new profile. See your administrator for information about obtaining your profile rights. However, if your Administrator grants you the appropriate rights to create a new profile, Interaction Attendant also automatically gives you the right to modify the profile. This feature allows you to edit any profile you create.

Node Characteristics frame

Options in this frame name the node, and establish whether or not it is active, logged, or tracked for reporting purposes.

The dialog box titled "Node Characteristics" contains a "Name:" label followed by an empty text input field. Below the input field are three checked checkboxes: "Active", "Enable IVR reporting", and "Add entry to the Interaction Log".

Name field

The label you enter here becomes the name of the node in the tree structure.

Active check box

By default, forms are "on", or "active", which means that Interaction Attendant will process them. If you uncheck a form's Active check box, the name of the node turns gray in the tree to indicate that the form is inactive. Interaction Attendant and its [handlers](#) will thereafter ignore the form and its children. Use this feature to save a configuration that you are testing. Inactive forms are invisible to callers. When a node is inactive, it appears grayed out in the tree view.

Enable IVR Reporting

This option determines whether or not reporting data will be collected when control passes through this node. Several IVR Reports summarize this information. IVR Reporting is *disabled* by default. Enable it to capture the date, time and duration of time that the call remained in the node and its children. This option is hidden when Attendant is connected to a server that does not have reporting installed. For more information about this feature, see [IVR Reporting Option](#).

Add entry to the Interaction log

When this option is enabled, information about this node is appended to the call's Interaction Log when the call enters this node. This helps track the path that a call took through Attendant. The Interaction Log is maintained for reporting purposes. See [View the Interaction Log](#) for details.

Mailboxes to Monitor

The dialog box titled "Mailboxes to Monitor:" contains a list of three items: "Marketing", "Sales", and "Support". Each item has a checkbox to its left. The checkboxes for "Marketing" and "Sales" are checked, while the checkbox for "Support" is unchecked.

The check boxes in this list determine which mailboxes are monitored by this profile. Mailboxes are configured outside of Attendant, in Interaction Administrator or Post Office Server.

Incoming E-mail Selection frame

Use this frame to define specific email addresses that this profile should match against "From" fields in email messages.

The dialog box titled "Incoming E-mail Selection" contains the following text: "Enter addresses seperated by comas. For further explanation of formatting, click the 'Formatting Help' button below." Below this text is a checked checkbox with the label "Use this profile to process incoming e-mail messages with any of the following addresses in the 'From:' field:". Underneath the checkbox is an empty text input field. At the bottom right of the dialog box is a button labeled "Formatting Help".

To enable entry of an email address, type email addresses in the text box. Use semicolons (;) to separate Multiple email addresses.

Email addresses are evaluated using a logical OR operator. A match occurs when any address in the profile matches an address in the email interaction.

Formatting Help button

The [E-Mail Formatting Help dialog](#) appears when the *Formatting Help* button is pressed. It displays tips for entering multiple email addresses and for using wildcards to filter a profile based upon "To", "Cc" and "From" fields in an email message.

Related Topics

- [Email Profiles](#)
- [Email Schedules](#)
- [Email Operations](#)

Schedules

A schedule stipulates when a menu can run, based upon the date, time, or special event. You can define schedules (and associated menus) to handle recurring events, holidays, or special situations, such as your regular business hours, after-hours support, or an office closing due to poor weather conditions. See [Schedule Types](#) for details.

Schedules are attached to [profiles](#). A single profile can have many child schedules. [Operations](#) are attached to schedules to build [menus](#).

Custom schedules define when a menu should be active based upon time-related criteria. Attendant creates a *default schedule* for you, and uses it when no custom schedules are defined, and when custom schedules do not match the current date or time.

Each [call flow](#) type (inbound, outbound, operator) provides default and custom schedules that have different property settings. Subsequent topics discuss these settings in detail.

Related Topics

- [Video: Use System schedules for holidays](#)
- [Call Schedules](#)
- [Operator Schedules](#)
- [Email Schedules](#)

Call Schedules

After a telephone call is matched to a [call profile](#), the receipt date/time of the call is compared to one or more [schedule nodes](#). Schedules select the menu that matches the current date, time of day, or a scheduled event, such as a holiday. Attendant provides default and custom schedules for inbound and outbound calls:

Inbound Calls	Outbound Calls
Default Inbound Call Schedule	Default Outbound Call Schedule
Custom Inbound Call Schedule	Custom Outbound Call Schedule

Custom Call Schedules determine whether a menu is active, based upon a date, range of dates, time, or a special event. Schedule forms stipulate when a menu can run. You can define schedules (and associated menus) to handle recurring events, holidays, or special situations, such as your regular business hours, after-hours support, or an office closing due to poor weather conditions.

Interaction Attendant automatically creates a *DefaultCall Schedule*, which it uses when no other schedule has precedence.

Default Inbound Call Schedule

Interaction Attendant automatically attaches a Default Inbound Call Schedule to each inbound profile. The default schedule ensures that all calls are processed, should a call arrive during a period that is undefined by custom schedule nodes.

The menu attached to the Default Inbound Call Schedule receives the call when no other schedule in the profile is selected based upon the current date, time, or events. The Default Inbound Call Schedule also has precedence if no custom schedules are defined for a profile.

Disabled Options

Since the Default Inbound Call Schedule is designed as a catch-all, some of its features are disabled:

- You cannot rename a Default Inbound Call Schedule or make it inactive.
- You cannot set *Schedule Start* and *Schedule End* dates, or specify daily, weekly, monthly, yearly, unplanned, or system schedule criteria.

However, all of these items can be configured for [Custom Inbound Call Schedules](#).

Configurable Options

The following aspects of a default schedule are configurable:

- You can set a voice prompt that plays when the schedule executes.
- You can set the maximum number of times that the voice prompt will be played before control is passed to the form's error handler. If you do not define special error handling the call is disconnected after the maximum number of playbacks.
- You can set the number of seconds to wait for user input before repeating the greeting.
- You can enable auto-detection of extension dialing, which sets up processing that Attendant interprets to handle multiple incoming digits as extension numbers, rather than as menu selections.
- You can tell Attendant to listen for fax tones, so that fax handling is automatically invoked should a call arrive from a fax machine. If a fax tone is detected, the fax is received in the Default Mailbox, or in the user or workgroup mailbox that you specify.
- You can optionally set error handling options to trap errors that might occur when menus are processed. The error handler can optionally play a message, and then transfer the call to a (user, station, or workgroup) [queue](#), or transfer the call to any menu that has defined for the server.
- You can configure and customize speech recognition settings configured in Interaction Administrator, including confidence level, timeouts, and to configure audio prompt settings when the speech engine cannot find a match to the caller's audio input. For more information, see [Configure Speech Recognition for Schedules and Menus](#).

All of these options are explained in the [Custom Inbound Call Schedule](#) topic.

Custom Inbound Call Schedule

After an inbound profile is selected, calls are filtered by the *schedules* below that profile. A Schedule determines whether a menu is active, based upon a date, range of dates, time, or a special event. Schedule forms stipulate when a menu can run. You can define schedules (and associated menus) to handle recurring events, holidays, or special situations, such as your regular business hours, after-hours support, or an office closing due to poor weather conditions.

- Daily, weekly, monthly and yearly schedules are fully supported.
- Unplanned schedules for events that have no fixed date ("snow day") must be activated to take effect, and can be [activated by phone](#).
- System schedules can be used to create a link between Interaction Attendant and schedules defined in Interaction Administrator.
- Interaction Attendant automatically creates a [default schedule](#), which it uses when no other schedule has precedence.

Node Characteristics frame

Options in this frame name the node, and establish whether or not it is active, logged, or tracked for IVR reporting purposes.

Name field

The label you enter here becomes the name of the node in the tree structure.

Active check box

This check box determines whether or not a schedule is considered by the system. If you uncheck this box, it is as if the schedule doesn't exist. Unchecked schedules are invisible to remote access operations. Note also that the Active check box does not activate an [unplanned schedule](#).

By default, forms are "on", or "active", which means that Interaction Attendant will process them. If you uncheck a form's Active check box, the name of the node turns gray in the tree to indicate that the form is inactive. Interaction Attendant and its [handlers](#) will thereafter ignore the form and its children. Use this feature to save a configuration that you are testing. Inactive forms are invisible to callers. When a node is inactive, it appears grayed out in the tree view.

When a schedule node is active, Interaction Attendant examines the schedule to see if it has precedence. When a schedule node is inactive, Interaction Attendant ignores the schedule and does not compare the current date and time to schedule dates and times.

Enable IVR Reporting

This option determines whether or not reporting data will be collected when control passes through this node. Several IVR Reports summarize this information. IVR Reporting is *disabled* by default. Enable it to capture the date, time and duration of time that the call remained in the node and its children. This option is hidden when Attendant is connected to a server that does not have reporting installed. For more information about this feature, see [IVR Reporting Option](#).

Add entry to the Interaction Log

When this option is enabled, information about this node is appended to the call's Interaction Log when the call enters this node. This helps track the path that a call took through Attendant. The Interaction Log is maintained for reporting purposes. See [View the Interaction Log](#) for details.

Configure Speech Recognition... button

Select this button to customize default speech recognition settings configured in Interaction Administrator, including confidence level, timeouts, and to configure audio prompt settings when the speech engine cannot find a match to the caller's audio input. For more information, see [Configure Speech Recognition for Schedules and Menus](#).

Schedule Greeting frame

Controls in this frame set a prompt to play when call control is passed to this schedule. If you do not select or record a prompt using the [embedded audio controls](#), no voice prompting will occur. See [manage voice prompts](#).

Repetition frame

Options in this frame set the maximum number of times that the voice prompt will be played before control is passed to the form's error handler.

Number of times to repeat this greeting spin control

This value determines the number of times that a greeting message will be played before control is passed to the form's error handler. If you do not modify the default error handling (by pressing the Schedule Error Handling button), the call will be disconnected after the maximum number of playbacks.

Number of seconds to wait before repeating spin control

This sets an interval, in seconds, that Interaction Attendant waits for user input before replaying the wave file.

By default, a schedule's greeting message is repeated three times with a 15-second wait for user-input in between. In releases prior to 2.3, repeat and repetition values were processed, even if the audio name field was left blank, or its value is <None>. For example, if the repeat count was 2 and the delay time was 10, the caller heard 20 seconds of dead air before the default action or error handler is invoked.

By default, a schedule's greeting message is repeated three times with a 15-second wait for user-input in between. In 4.0, if you publish a profile with a value of <none> in the audio field, the repeat count will be set to 0; however, you must modify the "seconds to wait before repeating" so the caller does not hear 15 seconds (the default value) of dead air.

Extension Dialing frame

Settings in this frame enable auto-detection of extension dialing, which sets up processing that Attendant interprets to handle multiple incoming digits as extension numbers, rather than as menu selections. See [Listen for Extension Dialing option](#) for details about this feature.

Fax Options button

Press this button to optionally configure Attendant to listen for Fax tones. This enables Fax handling, should a call arrive from a Fax machine. If a Fax tone is detected, the Fax is received in the server's Default Mailbox, or in the user or workgroup mailbox that you specify in the [Fax Listener Options Dialog](#).

Schedule Error Handling button

You can optionally set error handling options to trap errors that might occur when menus are processed. The error handler can optionally play a message, and then transfer the call to an operator profile, to a user, station, or workgroup [queue](#), or to any menu that has defined for the server. For details, refer to the [Default Error Handler Dialog](#).

Timezone drop-down list

Use the Timezone drop-down list to optionally configure a timezone setting. The CIC server uses the setting you select to

determine actual opening hours for this queue, based on the offset between the CIC server and the opening hours/timezone.

The timezone setting should be optionally and by default it should use the server time.

Note: The timezone for a schedule automatically adjusts to Daylight Saving Time (DST).

Schedule Start Date frame

Schedule Start Date and *Schedule End Date* settings do not determine when a menu will run. Instead, these controls set time boundaries that determine when scheduling criteria on the schedule tabs are evaluated.

The image shows two side-by-side configuration panels. The left panel is titled "Schedule Start Date" and contains the text "This schedule should take effect starting" above a date dropdown menu showing "11/19/2003". The right panel is titled "Schedule End Date" and contains two radio button options: "This schedule does not expire" (which is selected) and "This schedule expires on" (with a date dropdown menu showing "11/19/2003").

Start and End dates apply to daily, weekly, monthly and yearly schedules, but have no effect upon unplanned or system schedules. This schedule should take effect starting

This calendar control select the start date for the schedule.

1. To set a date, click the mouse on the date combo box. This displays a date selection dialog.

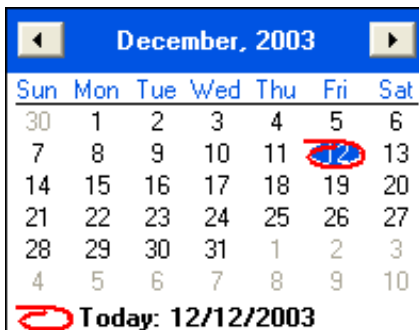

2. Use the pushbuttons to navigate to the previous or next month.
3. Click on a day of the month to select a new date.
4. The date selected has a blue fill. A red circle designates the current date.

Schedule End Date frame

Schedule End Date establishes when criteria on the schedule tabs should no longer be evaluated.

This schedule does not expire

This option indicates that the schedule should not expire, meaning that once the start date is reached, settings on the schedule tabs should always be evaluated.

This schedule expires on

This option sets a date when criteria on schedule tabs should be evaluated through. The schedule will be evaluated through the date set but not beyond it. Therefore, set this date to the last day when the schedule should be evaluated. For example, you might think that setting the end date to 9/1 would cause the schedule not to be evaluated after 8/31. However, in practice you must set the schedule end date to 8/31, because schedules are evaluated to the date listed, but not again afterwards.

Schedule Tabs

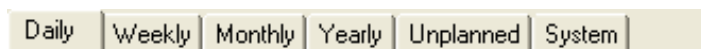

The tabbed pages at the bottom of the Schedule node set scheduling criteria. These settings establish daily, weekly, monthly, yearly, unplanned, or system criteria that determine when menu operations attached to the schedule will execute. See [Schedule](#)

[Types](#).

Related Topics

- [Call Schedules](#)

Default Outbound Call Schedule

Interaction Attendant automatically attaches a Default Outbound Call Schedule to each outbound profile. The default schedule ensures that all calls are processed, should a call arrive during a period that is undefined by custom schedule nodes.

The menu attached to the Default Outbound Call Schedule receives the call when no other schedule is selected for the profile, based upon the current date, time, or events. The Default Outbound Call Schedule also has precedence if no Custom Outbound Call Schedules are defined for a profile.

Disabled Options

Since the Default Outbound Call Schedule is designed as a catch-all, some of its features are disabled:

- You cannot rename a Default Outbound Call Schedule or make it inactive.
- You cannot set *Schedule Start* and *Schedule End* dates, or specify daily, weekly, monthly, yearly, unplanned, or system schedule criteria.

However, all of these items can be configured for Custom Outbound Call Schedules.

Configurable Options

The following aspects of a Default Outbound Call Schedule are configurable:

- You can set a voice prompt that plays when the schedule executes.
- You can set the maximum number of times that the voice prompt will be played before control is passed to the form's error handler. If you do not define special error handling the call is be disconnected after the maximum number of playbacks.
- You can set the number of seconds to wait for user input before repeating the greeting.
- You can enable auto-detection of extension dialing, which sets up processing that Attendant interprets to handle multiple incoming digits as extension numbers, rather than as menu selections.
- You can tell Attendant to listen for fax tones, so that fax handling is automatically invoked should a call arrive from a fax machine. If a fax tone is detected, the fax is received in the Default Mailbox, or in the user or workgroup mailbox that you specify.
- You can optionally set error handling options to trap errors that might occur when menus are processed. The error handler can optionally play a message, and then transfer the call to a (user, station, or workgroup) [queue](#), or transfer the call to any menu that has defined for the server.

These options are explained in the [Custom Outbound Call Schedule](#) topic.

Related Topics

- [Schedules](#)

Custom Outbound Call Schedule

Custom Outbound Call Schedules select one or more outbound call connections to process.

Node Characteristics frame

Options in this frame name the node, and establish whether or not it is active, logged, or tracked for IVR reporting purposes.

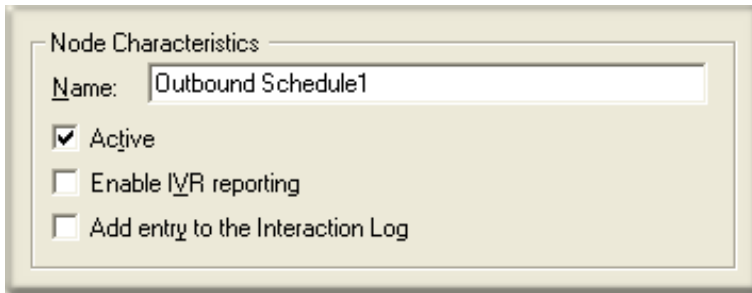

Node Characteristics

Name:

Active

Enable IVR reporting

Add entry to the Interaction Log

Name field

The label you enter here becomes the name of the node in the tree structure.

Active check box

This check box determines whether or not a schedule is considered by the system. If you uncheck this box, it is as if the schedule doesn't exist. Unchecked schedules are invisible to remote access operations. Note also that the Active check box does not activate an [unplanned schedule](#).

By default, forms are "on", or "active", which means that Interaction Attendant will process them. If you uncheck a form's Active check box, the name of the node turns gray in the tree to indicate that the form is inactive. Interaction Attendant and its [handlers](#) will thereafter ignore the form and its children. Use this feature to save a configuration that you are testing. Inactive forms are invisible to callers. When a node is inactive, it appears grayed out in the tree view.

When a schedule node is active, Interaction Attendant examines the schedule to see if it has precedence. When a schedule node is inactive, Interaction Attendant ignores the schedule and does not compare the current date and time to schedule dates and times.

Enable IVR Reporting

This option determines whether or not reporting data will be collected when control passes through this node. Several IVR Reports summarize this information. IVR Reporting is *disabled* by default. Enable it to capture the date, time and duration of time that the call remained in the node and its children. This option is hidden when Attendant is connected to a server that does not have reporting installed. For more information about this feature, see [IVR Reporting Option](#).

Add entry to the Interaction log

When this option is enabled, information about this node is appended to the call's Interaction Log when the call enters this node. This helps track the path that a call took through Attendant. The Interaction Log is maintained for reporting purposes. See [View the Interaction Log](#) for details.

Schedule Greeting frame

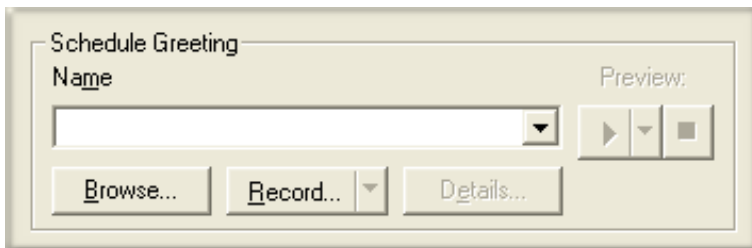

Schedule Greeting

Name Preview:

Controls in this frame set a prompt to play when call control is passed to this schedule. If you do not select or record a prompt using the [embedded audio controls](#), no voice prompting will occur. See [manage voice prompts](#).

Repetition frame

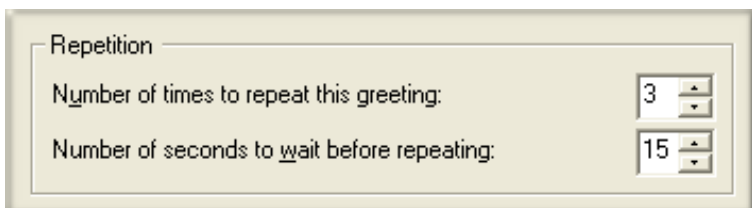

Repetition

Number of times to repeat this greeting:

Number of seconds to wait before repeating:

Number of times to repeat this greeting spin control

This value determines the number of times that a greeting message will be played before control is passed to the form's error

handler. If you do not modify the default error handling (by pressing the *Schedule Error Handling* button), the call will be disconnected after the maximum number of playbacks.

Number of seconds to wait before repeating spin control

This sets an interval, in seconds, that Interaction Attendant waits for user input before replaying the wave file.

margin-left: .3in; margin-right: 0in;

By default, a schedule's greeting message is repeated three times with a 15-second wait for user-input in between. In releases prior to 2.3, repeat and repetition values were processed, even if the audio name field was left blank, or its value is <None>. For example, if the repeat count was 2 and the delay time was 10, the caller heard 20 seconds of dead air before the default action or error handler is invoked.

The publish process now sets the repeat count and "seconds to wait before repeating" count to 0 for schedule nodes that don't have any audio specified. This prevents callers from hearing dead air if an Attendant user forgets to set those values to 0.

Schedule Error Handling button

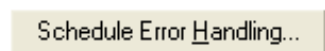

You can optionally set error handling options to trap errors that might occur when menus are processed. The error handler can optionally play a message, and then transfer the call to an operator profile, to a user, station, or workgroup [queue](#), or to any menu that has defined for the server. For details, refer to the [Default Error Handler Dialog](#).

Calls to Process frame

These options select which outbound call connections to process.

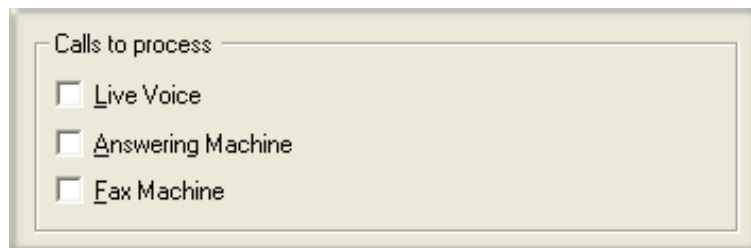

Live Voice

This option processes calls that were answered by a live person.

Answering Machine

This option processes calls that were answered by an answering machine.

Fax Machine

This option processes calls that were answered by a Fax machine.

Operator Schedules

When a telephone call is placed to an operator or operators, it is matched to an [operator profile](#). The date and time of the call is compared to one or more [schedule nodes](#). Schedules select the menu that matches the current date, time of day, or a scheduled event, such as a holiday. Attendant provides default and custom schedules for inbound operator calls:

- [Custom Operator Schedules](#) determine whether a menu is active, based upon a date, range of dates, time, or a special event. Schedule forms stipulate when a menu can run. You can define schedules (and associated menus) to handle recurring events, holidays, or special situations, such as your regular business hours, after-hours support, or an office closing due to poor weather conditions.
- Interaction Attendant automatically creates a [Default Operator Schedule](#), which it uses when no other schedule has precedence.

Default Operator Schedule

Attendant provides a call flow type for handling all calls routed to an operator or operators. The operator call flow tree configures all operator routing operations and allows for easy visualization of a server's operator processing. Interaction Attendant automatically attaches a default operator schedule to each operator profile. This insures that all operator calls are processed, if no custom operator schedules are defined or have precedence.

Operator schedules are like Inbound schedules, except that Operator call flows are managed in their own pane, separately from inbound call processing.

Disabled Options

Since the default operator schedule is designed as a catch-all, some of its features are disabled:

- You cannot rename a default schedule or make it inactive.
- Connection types (Live Voice, Answering Machine, Fax Machine) cannot be defined as selection criteria. However, these items can be configured for [custom operator schedules](#).

Configurable Options

The following aspects of a default schedule are configurable:

- You can play a greeting message when the schedule executes.
- You can set the maximum number of times that the voice prompt will be played before control is passed to the form's error handler. If you do not define special error handling the call is disconnected after the maximum number of playbacks.
- You can set the number of seconds to wait for user input before repeating the greeting.
- You can optionally set error handling options to trap errors that might occur when menus are processed. The error handler can optionally play a message, and then transfer the call to a (user, station, or workgroup) [queue](#), or transfer the call to any menu that has defined for the server.
- You can configure and customize speech recognition settings configured in Interaction Administrator, including confidence level, timeouts, and to configure audio prompt settings when the speech engine cannot find a match to the caller's audio input. For more information, see [Configure Speech Recognition for Schedules and Menus](#).

All of these options are explained in the [Custom Operator Schedule](#) topic.

Custom Operator Schedule

After an operator profile is selected, *schedules* below that profile determines whether a menu is active, based upon a date, range of dates, time, or a special event. Operator schedules are similar to Inbound schedules, except that Operator call flows are managed in their own pane, separately from inbound call processing.

You can define operator schedules (and associated menus) to handle recurring events, holidays, or special situations, such as your regular business hours, after-hours support, or an office closing due to poor weather conditions.

- Daily, weekly, monthly and yearly schedules are fully supported.
- Unplanned operator schedules for events that have no fixed date ("snow day") must be activated to take effect, and can be [activated by phone](#).
- System schedules allow Interaction Attendant to utilize schedules defined in Interaction Administrator.
- Interaction Attendant automatically creates a [default schedule](#), which it uses when no other schedule has precedence.

Node Characteristics frame

Options in this frame name the node, and establish whether or not it is active, logged, or tracked for IVR reporting purposes.

Name field

The label you enter here becomes the name of the node in the tree structure.

Active check box

This check box determines whether or not a schedule is considered by the system. If you uncheck this box, it is as if the schedule doesn't exist. Unchecked schedules are invisible to remote access operations. Note also that the Active check box does not activate an [unplanned schedule](#).

By default, forms are "on", or "active", which means that Interaction Attendant will process them. If you uncheck a form's Active check box, the name of the node turns gray in the tree to indicate that the form is inactive. Interaction Attendant and its [handlers](#) will thereafter ignore the form and its children. Use this feature to save a configuration that you are testing. Inactive forms are invisible to callers. When a node is inactive, it appears grayed out in the tree view.

When a schedule node is active, Interaction Attendant examines the schedule to see if it has precedence. When a schedule node is inactive, Interaction Attendant ignores the schedule and does not compare the current date and time to schedule dates and times.

Enable IVR Reporting

This option determines whether or not reporting data will be collected when control passes through this node. Several IVR Reports summarize this information. IVR Reporting is *disabled* by default. Enable it to capture the date, time and duration of time that the call remained in the node and its children. This option is hidden when Attendant is connected to a server that does not have reporting installed. For more information about this feature, see [IVR Reporting Option](#).

Add entry to the Interaction Log

When this option is enabled, information about this node is appended to the call's Interaction Log when the call enters this node. This helps track the path that a call took through Attendant. The Interaction Log is maintained for reporting purposes. See [View the Interaction Log](#) for details.

Configure Speech Recognition... button

Select this button to customize default speech recognition settings configured in Interaction Administrator, including confidence level, timeouts, and to configure audio prompt settings when the speech engine cannot find a match to the caller's audio input. For more information, see [Configure Speech Recognition for Schedules and Menus](#).

Schedule Greeting frame

Controls in this frame set a prompt to play when call control is passed to this schedule. If you do not select or record a prompt using the [embedded audio controls](#), no voice prompting will occur. See [manage voice prompts](#).

Repetition frame

Options in this frame set the maximum number of times that the voice prompt will be played before control is passed to the form's error handler.

Number of times to repeat this greeting spin control

This value determines the number of times that a greeting message will be played before control is passed to the form's error handler. If you do not modify the default error handling (by pressing the Schedule Error Handling button), the call will be disconnected after the maximum number of playbacks.

Number of seconds to wait before repeating spin control

This sets an interval, in seconds, that Interaction Attendant waits for user input before replaying the wave file.

By default, a schedule's greeting message is repeated three times with a 15-second wait for user-input in between. In releases prior to 2.3, repeat and repetition values were processed, even if the audio name field was left blank, or its value is <None>. For example, if the repeat count was 2 and the delay time was 10, the caller heard 20 seconds of dead air before the default action or error handler is invoked.

The publish process now sets the repeat count and "seconds to wait before repeating" count to 0 for schedule nodes that don't have any audio specified. This prevents callers from hearing dead air if an Attendant user forgets to set those values to 0.

Extension Dialing frame

Settings in this frame enable auto-detection of extension dialing, which sets up processing that Attendant interprets to handle multiple incoming digits as extension numbers, rather than as menu selections. See [Listen for Extension Dialing option](#) for details about this feature.

Fax Options button

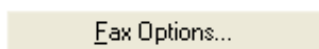

Press this button to optionally configure Attendant to listen for Fax tones. This enables Fax handling, should a call arrive from a Fax machine. If a Fax tone is detected, the Fax is received in the server's Default Mailbox, or in the user or workgroup mailbox that you specify in the [Fax Listener Options Dialog](#).

Schedule Error Handling button

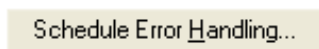

You can optionally set error handling options to trap errors that might occur when menus are processed. The error handler can optionally play a message, and then transfer the call to an operator profile, to a user, station, or workgroup [queue](#), or to any menu that has defined for the server. For details, refer to the [Default Error Handler Dialog](#).

Timezone drop-down list

Use the Timezone drop-down list to optionally configure a timezone setting. The CIC server uses the setting you select to determine actual opening hours for this

queue, based on the offset between the CIC server and the opening hours/timezone.

The timezone setting should be optionally and by default it should use the server time.

Note: The timezone for a schedule automatically adjusts to Daylight Saving Time (DST).

Schedule Start Date frame

Schedule Start Date and *Schedule End Date* settings do not determine when a menu will run. Instead, these controls set time boundaries that determine when scheduling criteria on the schedule tabs are evaluated.

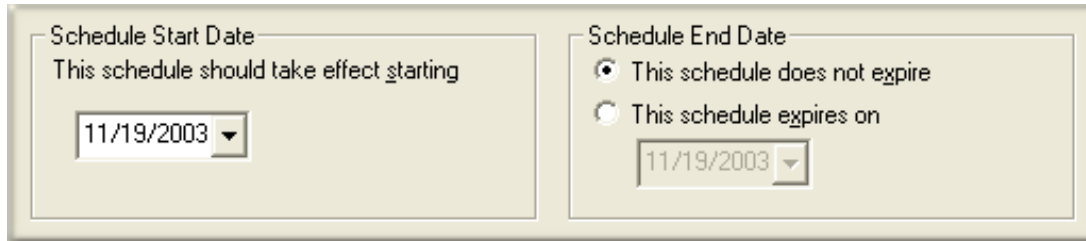

Start and End dates apply to daily, weekly, monthly and yearly schedules, but have no effect upon unplanned or system schedules.

This schedule should take effect starting

This calendar control select the start date for the schedule.

1. To set a date, click the mouse on the date combo box. This displays a date selection dialog.

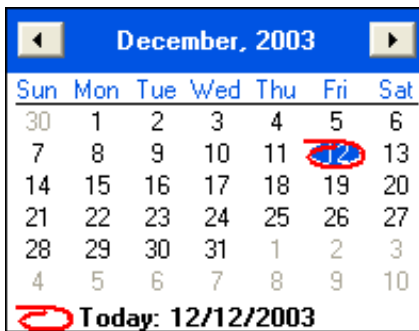

2. Use the pushbuttons to navigate to the previous or next month.
3. Click on a day of the month to select a new date.
4. The date selected has a blue fill. A red circle designates the current date.

Schedule End Date frame

Schedule End Date establishes when criteria on the schedule tabs should no longer be evaluated.

This schedule does not expire

This option indicates that the schedule should not expire, meaning that once the start date is reached, settings on the schedule tabs should always be evaluated.

This schedule expires on

This option sets a date when criteria on schedule tabs should be evaluated through. The schedule will be evaluated through the date set but not beyond it. Therefore, set this date to the last day when the schedule should be evaluated. For example, you might think that setting the end date to 9/1 would cause the schedule not to be evaluated after 8/31. However, in practice you must set the schedule end date to 8/31, because schedules are evaluated to the date listed, but not again afterwards.

Schedule Tabs

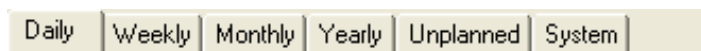

The tabbed pages at the bottom of the Schedule node set scheduling criteria. These settings establish daily, weekly, monthly, yearly, unplanned, or system criteria that determine when menu operations attached to the schedule will execute. See [Schedule Types](#).

Related Topics

- [Schedules](#)

Email Schedules

When an email message is matched to an [Email Profile](#), the date and time of the call is compared to one or more [schedule nodes](#). Schedules select the menu that matches the current date, time of day, or a scheduled event, such as a holiday. Attendant provides default and custom schedules for inbound operator calls:

- [Custom Email Schedules](#) pass control to a menu, based upon a date, range of dates, time, or a special event. Schedule forms stipulate when a menu can run. You can define schedules (and associated menus) to handle recurring events, holidays, or special situations, such as your regular business hours, after-hours support, or an office closing due to poor weather conditions.
- Interaction Attendant automatically creates a [Default Email Schedule](#), which it uses when no other schedule has precedence.

Default Email Schedule

Interaction Attendant automatically attaches a *Default Email Schedule* to each Email profile. The default schedule ensures that all Email messages are processed, should a message arrive during a period that is undefined by *Custom Email Schedules*.

The menu attached to the *Default Email Schedule* receives control when no other schedule in the profile is selected based upon the current date, time, or events. The *Default Email Schedule* also has precedence if no custom schedules are defined for a profile.

Disabled Options

Since the *Default Email Schedule* is designed as a catch-all, some of its features are disabled:

- You cannot rename a *Default Email Schedule* or make it inactive.
- You cannot set *Schedule Start* and *Schedule End* dates, or specify daily, weekly, monthly, yearly, unplanned, or system schedule criteria.

These restrictions do not apply to [Custom Email Schedules](#).

Configurable Options

The following aspects of a *Default Email Schedule* are configurable:

- You can add an entry to the Interaction log. When this option is checked, information about this node is appended to the Email's Interaction Log when the call enters this node. This helps track the path that the interaction took through Attendant. Interaction Logs are maintained for reporting purposes. See [View the Interaction Log](#) for details.
- You can press the *Schedule Error Handling* button to optionally set error handling options to trap errors that might occur when menus are processed. The error handler can disconnect the interaction, or transfer the Email message to a menu, user queue or workgroup queue. See [Default Error Handler Dialog \(Emails\)](#).

Custom Email Schedule

After an Email profile is selected, calls are filtered by the Email *schedules* below that profile. Schedules are evaluated to select a menu, based upon a date, range of dates, time, or a special event. Schedules stipulate when a menu can run. You can define schedules (and associated menus) to handle recurring events, holidays, or special situations, such as your regular business hours, after-hours support, or an office closing due to poor weather conditions.

- Daily, weekly, monthly and yearly schedules are fully supported.
- Unplanned schedules for events that have no fixed date ("snow day") must be activated to take effect, and can be [activated by phone](#).
- System schedules can be used to create a link between Interaction Attendant and schedules defined in Interaction Administrator.
- Interaction Attendant automatically creates a [Default Email Schedule](#), which it uses when no other schedule has precedence.
- Email schedule nodes are similar to Call schedule nodes, except that Call actions that do not apply to Email objects (play audio file, transfer to a station group) are not available. Otherwise, the options for specifying dates, times, and periodicity of an Email routing schedule are identical to Call schedules.
- Email schedules provide different error handling actions. If there is an error during the processing of an Email anywhere under a schedule, the Email can be disconnected, or transferred to a specific user or workgroup queue.

Node Characteristics frame

Options in this frame name the node, and establish whether or not it is active, logged, or tracked for IVR reporting purposes.

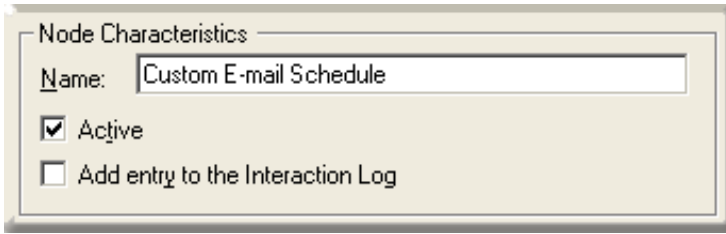
A dialog box titled "Node Characteristics" with a light beige background. It contains a text input field labeled "Name:" with the text "Custom E-mail Schedule" entered. Below the input field are two checkboxes: "Active" which is checked, and "Add entry to the Interaction Log" which is unchecked.

Name field

The label you enter here becomes the name of the node in the tree structure.

Active check box

This check box determines whether or not a schedule is considered by the system. If you uncheck this box, it is as if the schedule doesn't exist. Unchecked schedules are invisible to remote access operations. Note also that the Active check box does not activate an [unplanned schedule](#).

By default, forms are "on", or "active", which means that Interaction Attendant will process them. If you uncheck a form's Active checkbox, the name of the node turns gray in the tree to indicate that the form is inactive. Interaction Attendant and its [handlers](#) will thereafter ignore the form and its children. Use this feature to save a configuration that you are testing. Inactive forms are invisible to callers. When a node is inactive, it appears grayed out in the tree view.

When a schedule node is active, Interaction Attendant examines the schedule to see if it has precedence. When a schedule node is inactive, Interaction Attendant ignores the schedule and does not compare the current date and time to schedule dates and times.

Add entry to the Interaction log

When this option is enabled, information about this node is appended to the Interaction Log when the Interaction is processed by this node. This helps track the path that it took through Attendant. The Interaction Log is maintained for reporting purposes. See [View the Interaction Log](#) for details.

Schedule Error Handling button

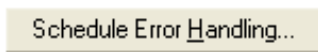
A rectangular button with a light beige background and a thin border. The text "Schedule Error Handling..." is displayed in a dark font.

You can optionally set error handling options to trap errors that might occur when menus are processed. You can terminate the Email interaction, or transfer the Email message to a menu, user queue, or workgroup queue. See [Default Error Handler Dialog \(Emails\)](#).

Timezone drop-down list

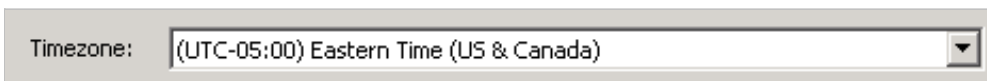
A drop-down menu with a light beige background. The label "Timezone:" is on the left. The selected option is "(UTC-05:00) Eastern Time (US & Canada)". A small downward-pointing arrow is visible on the right side of the menu.

Use the Timezone drop-down list to optionally configure a timezone setting. The CIC server uses the setting you select to determine actual opening hours for this queue, based on the offset between the CIC server and the opening hours/timezone.

The timezone setting should be optionally and by default it should use the server time.

Note: The timezone for a schedule automatically adjusts to Daylight Saving Time (DST).

Schedule Start Date frame

Schedule Start Date and *Schedule End Date* settings do not determine when a menu will run. Instead, these controls set time boundaries that determine when scheduling criteria on the schedule tabs are evaluated.

<p>Schedule Start Date</p> <p>This schedule should take effect starting</p> <p>11/19/2003 ▾</p>	<p>Schedule End Date</p> <p><input checked="" type="radio"/> This schedule does not expire</p> <p><input type="radio"/> This schedule expires on</p> <p>11/19/2003 ▾</p>
---	--

Start and End dates apply to daily, weekly, monthly and yearly schedules, but have no effect upon unplanned or system schedules.

This schedule should take effect starting

This calendar control selects a start date for the schedule.

1. To set a date, click the mouse on the date combo box. This displays a date selection dialog.



2. Use the pushbuttons to navigate to the previous or next month.
3. Click on a day of the month to select a new date.
4. The date selected has a blue fill. A red circle designates the current date.

Schedule End Date frame

Schedule End Date establishes when criteria on the schedule tabs should no longer be evaluated.

This schedule does not expire

This option indicates that the schedule should not expire, meaning that once the start date is reached, settings on the schedule tabs should always be evaluated.

This schedule expires on

This option sets a date when criteria on schedule tabs should be evaluated through. The schedule will be evaluated through the date set but not beyond it. Therefore, set this date to the last day when the schedule should be evaluated. For example, you might think that setting the end date to 9/1 would cause the schedule not to be evaluated after 8/31. However, in practice you must set the schedule end date to 8/31, because schedules are evaluated to the date listed, but not again afterwards.

Schedule Tabs

Daily	Weekly	Monthly	Yearly	Unplanned	System
-------	--------	---------	--------	-----------	--------

The tabbed pages at the bottom of the Schedule node set scheduling criteria. These settings establish daily, weekly, monthly, yearly, unplanned, or system criteria that determine when menu operations attached to the schedule will execute. See [Schedule Types](#).

Schedule Types

The tab pages at the bottom of a Schedule node establish criteria that determine when the menu attached to the schedule will execute. Attendant evaluates settings on the active tab only. It ignores settings on the other tabs.

Each tab represents a discrete type of criteria that determines when a menu will execute. Interaction Attendant is flexible and accommodates a wide range of scheduling needs. It provides many scheduling options—some of which you may never use.

It is entirely possible to activate a menu using different types of schedule criteria. For example, a schedule that runs all day, every day, could be defined by setting options on the daily tab, or by setting options on the weekly tab. One method isn't more correct than another, so long as a schedule works that way you need it to.

Schedule tabs are disabled on the [default schedule](#), since it is designed to catch calls that other schedules do not trap. Custom schedules allow you to establish the following schedule criteria:

Daily Runs a schedule at the same time every day between the schedule start date and the schedule end date.

Weekly Runs a schedule on a particular day or days of the week.

Monthly Runs a schedule on a particular day or date range every month.

Yearly Runs a schedule on a particular date or range of dates every year.

Unplanned Allows you to define schedules that run during specific times of the day, but without specifying any particular date. This is useful for snow days, or unplanned office closings.

System System schedules link an Interaction Attendant schedule to a system schedule defined in Interaction Administrator. This permits changes made in Interaction Administrator to be reflected by Auto-Attendant processing.

Priority order criteria that CIC uses to pick a schedule

The type of schedule determines the order in which CIC selects the schedule to play. The order of priority is as follows:

- Unplanned: Highest priority.
- One Time. This is an Interaction Administrator schedule type. The One Time schedule should not be confused with the Unplanned schedule type available in Interaction Attendant. An unplanned schedule specifies an indefinite end time, staying active until it is turned off. See [Unplanned Schedules](#).
- Yearly
- Monthly
- Weekly
- Daily: Lowest priority

If there is more than one schedule that matches in priority, then the start times are compared. The schedule containing the closest comparable times is the higher priority.

Settings on inactive tabs are ignored

You may be wondering, what happens if I set options on more than one tab? Does Attendant reconcile schedule settings on all of the tabs? The answer is that it does not. Attendant evaluates settings on the active tab only. It ignores settings on all other tabs.

Subsequent pages explain each scheduling tab in detail.

Daily Schedules

Daily Weekly Monthly Yearly Unplanned System

Use "Daily" for schedules that run at the same time every day between the start date and end date displayed above.

Time Range

- This schedule should run all day
- This schedule should run between these times

Start 8:00 AM

End 6:00 PM

Daily schedules run a menu at the same time every day, between the start date and the end date. The menu can run all day, or between start and end times.

Settings on this tab are evaluated only if the call arrives between the *Schedule Start* and *Schedule End* date and time. The Schedule's *Active* check box must also be checked.

Time Range frame

This schedule should run all day

Runs the schedule all day, every day.

This schedule should run between these times

Runs the schedule every day between the starting and ending times.

Example Daily Schedule

The example schedule below is designed to run seven days a week, 365 days a year from 8 AM to 5 PM every day.

Daily Weekly Monthly Yearly Unplanned System

Use "Daily" for schedules that run at the same time every day between the start date and end date displayed above.

Time Range

- This schedule should run all day
- This schedule should run between these times

Start 8:00 AM

End 5:00 PM

Selecting the daily tab creates a schedule that runs every day, without regard for the day of the week, day of the month or any other constraint.

Daily schedules can be set up to become active for a certain time window each day (8 AM – 5 PM in the example above) by selecting the "This schedule should run between these times" option in the time range box. Similarly, the schedule can be set to run all day, 24 hours a day, by selecting the "This schedule should run all day" option in the same box.

A daily schedule that is set to run all day essentially replaces the default schedule for the date range specified in the Schedule Start Date box and the Schedule End Date box.

Holiday Schedule Example

This schedule shows how to handle a specific holiday—in this case, Thanksgiving. It will be active all day, 24 hours a day from the 23rd through the 26th of November.

The screenshot shows a configuration window for a schedule. It is divided into several sections:

- Schedule Start Date:** A dropdown menu showing "11/25/2003".
- Schedule End Date:** Two radio buttons. The first is "This schedule does not expire" (unselected). The second is "This schedule expires on" (selected), with a dropdown menu showing "11/27/2003".
- Frequency:** A row of tabs: "Daily" (selected), "Weekly", "Monthly", "Yearly", "Unplanned", and "System".
- Instructions:** Text below the tabs: "Use 'Daily' for schedules that run at the same time every day between the start date and end date displayed above."
- Time Range:** A box containing two radio buttons. The first is "This schedule should run all day" (selected). The second is "This schedule should run between these times" (unselected). Below these are two time selection fields: "Start" with a value of "8:00 AM" and "End" with a value of "5:00 PM".

By setting the Schedule Start Date and Schedule End Date to fields to specific dates and then creating a daily schedule, it is possible to define schedules that handle specific holidays or vacation periods. The schedule above will take effect at midnight on the 25th of November 2003 (Thanksgiving) and continue to run until midnight on November 27th 2003.

A user could create a yearly schedule to handle holidays like Thanksgiving and Christmas, but since the actual vacation dates usually fall on different calendar day each year, daily schedules with specific start and end dates work as well.

Weekly Schedules

Daily
 Weekly
 Monthly
 Yearly
 Unplanned
 System

Use "Weekly" for schedules that run on a particular day or days of the week.

Start on: 8:00 AM
 End on: 9:00 PM

Time Range
 This schedule should run all day
 This schedule should run between
 Start:
 End:

Days
 Sunday
 Monday
 Tuesday
 Wednesday
 Thursday
 Friday
 Saturday

Weekly schedules run a menu on a particular day or days of the week. The menu can run all day, or between start and end times.

Settings on this tab are evaluated only if the call arrives between the *Schedule Start* and *Schedule End* date and time. The Schedule's *Active* check box must also be checked.

Start On (Day of Week) combo box

Selects the day when the schedule starts in relation to days selected in the Days frame.

Start On (Time) spin control

Sets a start time for the start day.

End On (Day of Week) combo box.

Sets a day of week for the schedule to end on in relation to days selected in the Days frame.

End On (Time) spin control

Sets an end time for the end day.

Time Range frame

This schedule should run all day radio button

This option runs the menu all day during the days selected.

The schedule should run between radio button

Runs the menu between specific start and end times during the days selected.

Days frame

These check boxes select specific days of the week for the schedule to run on.

All button

Checks all days of week check boxes.

None button

Unchecks all days of week check boxes.

M - F button

Checks days of week from Monday to Friday.

Weekends

Checks Saturday and Sunday only.

Typical Work Week Example

The example schedule below is designed to run during a typical workweek, 8 AM to 5 PM each day, Monday through Friday.

The screenshot shows a scheduling interface with the following elements:

- Navigation tabs: Daily, Weekly (selected), Monthly, Yearly, Unplanned, System.
- Instruction: "Use 'Weekly' for schedules that run on a particular day or days of the week."
- Start on: Monday, 8:00 AM.
- End on: Friday, 5:00 PM.
- Time Range section:
 - Radio buttons: "This schedule should run all day" (unselected), "This schedule should run between" (selected).
 - Start: 8:00 AM.
 - End: 5:00 PM.
- Days section:
 - Checkboxes: Sunday (unselected), Monday (checked), Tuesday (checked), Wednesday (checked), Thursday (checked), Friday (checked), Saturday (unselected).
 - Buttons: All, None, M _ F, Weekends.

Selecting the Weekly tab creates a schedule that runs on a particular day or days of the week, regardless of calendar date. Weekly schedules can be used for reoccurring weekly events or for things like the standard work week.

The schedule shown above is set to become active every Monday morning at 8 AM. It will become dormant again on Friday evening at 5 PM. Because the Time Range selection is set to "This schedule should run between", the schedule will only be active from 8 AM and 5 PM each day.

If the time range selection in this example was changed to be "This schedule should run all day", then the schedule would become active at 8 AM on Monday and run 24 hours a day each day until 5 PM on Friday.

By using the check boxes in the Days box, you could also configure the schedule to run on only some of the days between Monday and Friday. As the "Start on" and "End on" fields are changed, the individual days of the week in the Days box will be enabled or disabled, showing the complete range of days that the schedule would be active as specified by the schedule.

The check boxes can then be used to either turn on or off the schedule for a given day. In the example above, the schedule is set to run each day from Monday through Friday. If a user clicked on the Wednesday check box so that its check mark disappeared, the schedule would then be configured to run from 8 AM to 5 PM on Mondays, Tuesdays, Thursdays and Fridays, and not run at all on Wednesdays.

Short Workday Example

The example below illustrates a workweek where the office shuts down on noon every Friday. It will run from 7 AM to 5 PM on Monday through Thursday and run from 7 AM to noon on Friday.

Use "Weekly" for schedules that run on a particular day or days of the week.

Start on 7:00 AM
 End on 12:00 PM

Time Range
 This schedule should run all day
 This schedule should run between
 Start
 End

Days
 Sunday
 Monday
 Tuesday
 Wednesday
 Thursday
 Friday
 Saturday

The schedule above is very similar to the weekly schedule, except that it is set to start at 7 AM instead of 8 AM, and the "End on" fields are set to Friday at noon instead of Friday at 5 PM.

This has the effect of turning the schedule off at noon on Friday, but not affecting the rest of the week. (7 AM – 5 PM Monday through Thursday, 7 AM – 12 PM on Friday). The weekly schedule is designed so that it will not start any earlier on the first day than the day of week and time specified by the "Start on" fields and will not run any later on the last day than the date of week and time specified by the "End on" fields. This gives the user the ability to set up a schedule that starts later on the first day of the schedule or ends earlier on the last day of the schedule.

Evening Schedule Example

This schedule was designed to run after hours during the typical workweek. Monday through Thursday night, this schedule will become active and run from 5 PM until 8 AM the next morning. The evening of Friday night was left out of the schedule because it can be covered by a weekend schedule.

Use "Weekly" for schedules that run on a particular day or days of the week.

Start on 5:00 PM
 End on 8:00 AM

Time Range
 This schedule should run all day
 This schedule should run between
 Start
 End

Days
 Sunday
 Monday
 Tuesday
 Wednesday
 Thursday
 Friday
 Saturday

This schedule was designed to handle all the "After hours" calls that come in once the company's employees have gone home for the night. When a schedule is set up to run between 5 PM and 8 AM in the Time Range box, the schedule will start at 5 PM one evening and continue running until 8 AM the following morning.

Weekend Schedule Example

This schedule was designed to run for the entire weekend. It will become active at 5 PM on Friday night and run 24 hours a day until Monday morning at 8 AM.

Daily Weekly Monthly Yearly Unplanned System

Use "Weekly" for schedules that run on a particular day or days of the week.

Start on: Friday 5:00 PM

End on: Monday 8:00 AM

Time Range

This schedule should run all day

This schedule should run between

Start: 5:00 PM

End: 8:00 AM

Days

Sunday

Monday

Tuesday

Wednesday

Thursday

Friday

Saturday

All None

M _ F Weekends

This schedule has its time range set to "This schedule should run all day", so it will begin running at the day and time specified by the "Start on" fields and run 24 hours a day, each day until the day and time specified by the "End on" fields.

Monthly Schedules

Daily Weekly Monthly Yearly Unplanned System

Use "Monthly" for schedules that run on a particular day or date range every month.

Start Day

First day of the Month

Last Day of the month

Particular Day 1

End Day

First day of the Month

Last Day of the month

Particular Day 31

Time Range

This schedule should run all day

This schedule should run between

Start: 8:00 AM

End: 6:00 PM

Monthly schedules run on a particular day or range of dates each month. You must set boundary dates to identify when the schedule starts and ends. You must also specify whether the schedule runs all day, or between specific times of day.

Settings on this tab are evaluated only if the call arrives between the *Schedule Start* and *Schedule End* date and time. The Schedule's *Active* check box must also be checked.

Start Day frame

First day of the Month

Configures the schedule to start on the first day of the month.

Last day of the Month

Configures the schedule to start on the last day of the month.

Particular Day

Configures the schedule to start on any day of the month.

End Day frame

First day of the Month

Configures the schedule to end on the first day of the month.

Last day of the Month

Configures the schedule to end on the last day of the month.

Particular Day

Configures the schedule to end on any day of the month.

Time Range frame

These options restrict the schedule to specific starting and ending times, or set the schedule to run all day.

This schedule should run all day

Indicates that the schedule should run all day between Start Day and End Day.

This schedule should run between

This option allows you run the schedule between start and end times, between Start Day and End Day.

End-of-Month Schedule Example

The end-of-month schedule below handles a special situation that happens at the end of every month.

Daily | Weekly | Monthly | Yearly | Unplanned | System

Use "Monthly" for schedules that run on a particular day or date range every month.

<p>Start Day</p> <p><input type="radio"/> First day of the Month</p> <p><input checked="" type="radio"/> Last Day of the month</p> <p><input type="radio"/> Particular Day <input type="text" value="1"/></p>	<p>End Day</p> <p><input type="radio"/> First day of the Month</p> <p><input checked="" type="radio"/> Last Day of the month</p> <p><input type="radio"/> Particular Day <input type="text" value="31"/></p>
<p>Time Range</p> <p><input checked="" type="radio"/> This schedule should run all day</p> <p><input type="radio"/> This schedule should run between</p> <p>Start <input type="text" value="8:00 AM"/></p> <p>End <input type="text" value="6:00 PM"/></p>	

Monthly schedules are configured by selecting the day of the month that the schedule should take effect in the Start Day box and the last day of the month that the schedule should be effective in the End Day box.

For example, Selecting "First day of the month" in the Start Day box and selecting "Particular day" in the End Day box and setting the associated control to 7 would create a schedule that becomes active on the first day of the month and continues to stay active through the 7th day of the month, every month.

The "Last day of the month" option gives a user the ability to configure a schedule to start or end on the last day of the month regardless of what day that might be (28th, 29th, 30th or 31st).

Like the time ranges, selecting a day of the month in the Start Day box that is later in the month than the day selected in the End Day box will create a schedule that becomes active on the day specified in the Start Day box of one month and continues to be active through the day specified in the End Day box of the following month.

Yearly Schedules

Daily | Weekly | Monthly | **Yearly** | Unplanned | System

Use "Yearly" for schedules that occur on a particular date or range of dates every year.

Start on

End on

Time Range

This schedule should run all day

This schedule should run between

Start

End

Yearly schedules are infrequently used, since they set schedule boundaries based upon fixed dates and times. For example, this option might be used to schedule a menu that runs from Christmas Eve through the end of the year, or on New Years day only.

Settings on this tab are evaluated only if the call arrives between the *Schedule Start* and *Schedule End* date and time. The Schedule's *Active* check box must also be checked.

Unplanned Schedules

Daily Weekly Monthly Yearly **Unplanned** System

Use "Unplanned" for schedules that have a specific time range, but an uncertain date, like a snow day or other unplanned closing or delay

Time Range

This schedule should run all day

This schedule should run between these times

Start 12:00 AM

End 12:00 AM

Duration

This schedule will stay active until it is turned off

This schedule will expire after it has run once

Schedule1 is now in effect.

Unplanned schedules are useful when you don't know exactly when a menu will be needed. For example, you might create a menu for a snow day, and remotely activate the schedule over the phone when bad weather conditions affect business hours.

Time Range frame

These settings control the time of day that the schedule should run.

This schedule should run all day

Sets the schedule to run all day.

This schedule should run between these times

Enables spin controls that set runtime start and end times.

Duration Frame

Options in the *Duration* frame control how long the unplanned schedule remains in effect.

This schedule will stay active until it is turned off

Sets the schedule to run until it is manually deactivated. A snow day schedule, for example, could continue to run every day until you turn it off.

This schedule will expire after it has run once

This option tells schedule to automatically deactivate itself once its time range expires.

Schedule is now in effect check box

To activate an unplanned schedule, check the *schedule is now in effect* check box, or use remote access services to activate the schedule remotely using a touch-tone telephone. To activate an unplanned schedule using the telephone, you must have Modify permissions set on the Inbound Profiles category at the user, workgroup, or role level. To learn how to use remote access services, see [Remotely Activate an Unplanned Schedule](#).



Remotely Activate an Unplanned Schedule

Unplanned schedules are useful when you don't know exactly when a menu will be needed. For example, you can create a menu for a snow day, and activate the schedule when bad weather conditions affect business operations. If you are in the office, you can use Interaction Attendant to activate an unplanned schedule by opening the schedule, and checking its *now in effect* check box.

If you are out of the office, you can activate an unplanned schedule using a touch-tone telephone. The following caveats apply:

- Only unplanned schedules can be activated using a the telephone. You cannot activate other schedule types (daily, weekly, etc.) using remote access services.
- To activate an unplanned schedule using the telephone, you must have Modify permissions set on the Inbound Profiles category at the user, workgroup, or role level. For details concerning access rights, refer to the Interaction Administrator help system.

Steps to Remotely Activate an Unplanned Schedule

The process of remotely activating an unplanned schedule is similar to the procedure used to remotely access voice mail, faxes, and Email using a telephone. You dial into the CIC Server, identify yourself, and make selections from a menu tree. Here's what to do:

1. Call the CIC server, by dialing your company's main telephone number. If you are at a station that is connected directly to the CIC, you may dial an asterisk (*) instead of the main number.
2. Dial **99**, followed by your **extension** number, your **password**, and a pound (#) sign. The CIC does not prompt for your extension and password.

The CIC plays a "Welcome to voicemail for extension nnnn" message. You are prompted to press 5 for *Personal Options*.

3. Press **5** to select Personal Options.
4. Press **9** to enter the Interaction Attendant submenu. A text-to-speech voice prompt is played for this option. You must have Modify permissions set on the Inbound Profiles to use this option. The system builds a list of Profiles that contain at least one unplanned Schedule. From this point on, voice prompts are generated using text-to-speech technology. The system dictates a list of profiles you can choose from:

"To modify unplanned schedules for <Profile_Name>, press n"

5. Press the digit (n) that corresponds to the profile you wish to select. This causes the CIC to build a list of unplanned schedules for the selected profile. It dictates schedule names to you, so that you can make a selection:

To modify the unplanned schedule, <Schedule_Name>, press n"

6. Press the digit that corresponds to the unplanned schedule you wish to activate or deactivate. The voice prompt that you hear next varies.

If the schedule is currently **inactive**, the voice prompt is "To activate <Schedule Name>, press 1".

If the schedule is currently **active**, the prompt is "To deactivate <Schedule_Name>, press 1".

7. Press **1** to activate or deactivate the schedule. The system responds with a message stating that "schedule <Schedule_Name> has been" activated or deactivated.

At this point, control returns to the menu that you entered in step three.

System Schedules

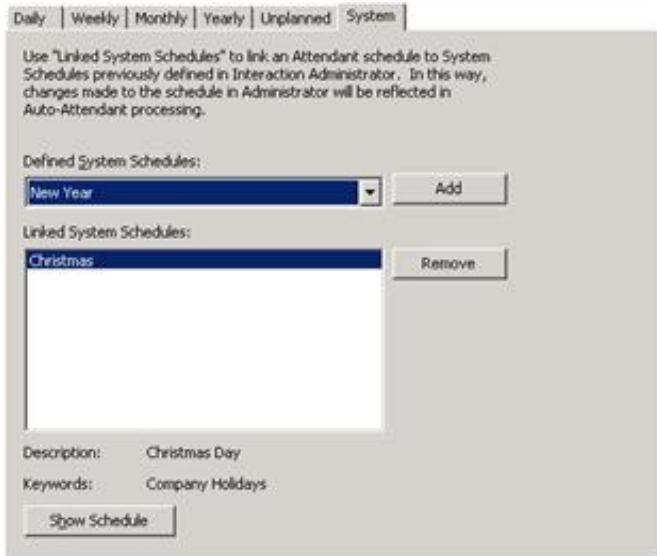

Schedules can be defined in Interaction Attendant, and also in Interaction Administrator using the *People > Schedules* container. Schedules created in Interaction Administrator are similar to schedules created in Interaction Attendant; both define a span of time. The *System Schedule* type in Interaction Attendant allows you to utilize one or more schedules that were defined in Interaction Administrator. This creates a linkage that allows the Attendant schedule to utilize schedule configurations managed in Interaction Administrator.

The figure below shows a schedule entry in Interaction Administrator:

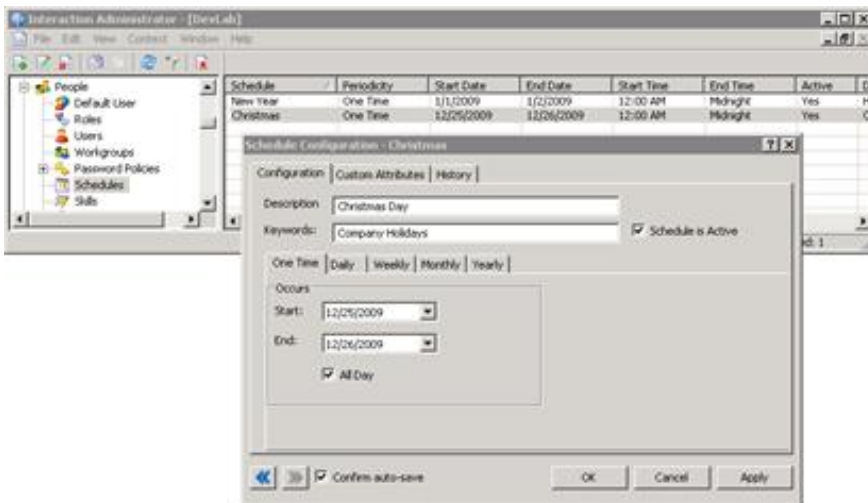

System schedules have no effect on Interaction Attendant unless you create an Interaction Attendant schedule form, choose the System tab, and add the names of schedules to the *Linked System Schedules* list. Interaction Attendant can read system schedules, but it cannot modify them.

For more information about schedules in Interaction Administrator, refer to the topic titled *About Schedules* in the *Interaction Administrator Help*.

System Schedule frame

Defined System Schedules

This list contains the names of system schedules that have been defined in Interaction Administrator. To link an Interaction Attendant schedule to an Interaction Administrator system schedule, choose a system schedule from the list, and then click Add. Repeat to add additional schedules as needed.

Once a link is in place, changes made to the schedule using Interaction Administrator are automatically reflected in the auto-attendant processing. Interaction Attendant's handlers read and interpret system schedules in order to determine which menu to play at any given moment of any given day.

Linked System Schedules list

This list contains the names of schedules in Interaction Administrator that you have linked for use in this Attendant schedule. Clicking the Remove button removes the selected schedule from this list.

Show Schedule button

Click this button to display system schedule settings, which are read-only. Then click OK to close the System Schedule dialog.

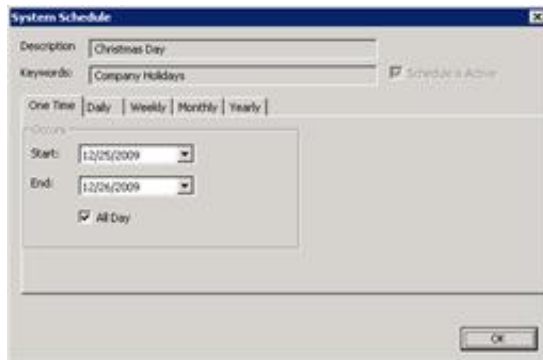

Note—Prior to Interaction Attendant 2.1, system schedules that were marked inactive in Interaction Administrator did not appear in the System Schedule combo box. In Attendant v2.1 and later, inactive system schedules appear in the combo box as grayed out items with an inactive marker. This makes it possible to select an inactive schedule that might be made active later.

Additional information about system schedules can be found in the Interaction Administrator help.

Resolution of Schedule Conflicts

Scheduling conflicts can occur when two menus are scheduled to play at the same time. For example, both the December 25 and the weekend menu are scheduled to play on a particular Saturday. Interaction Attendant will play the December 25 menu because days of the year take priority over days of the week.

This list below demonstrates how Interaction Attendant determines which schedule to play in a conflict.

Yearly

An unplanned menu scheduled to run on a specific day of the year takes priority over any other menu, if the unplanned menu is activated. That means that if you have a Saturday menu and Christmas menu, and Christmas falls on Saturday, the Christmas menu is played.

Monthly

A menu based upon monthly criteria takes priority over a menu scheduled to run every week.

Weekly Schedule

A menu scheduled to run on a specific day of the week takes priority over a menu scheduled to run every day. For example, if you have a lunch menu that plays every day from 1 until 2, and a weekend menu that plays on Saturday and Sunday, the weekend menu has priority.

Daily Schedule

If there is an overlap between two menus both scheduled to run every day, then the menu that started more recently is used. For example, suppose you have a menu that runs every day from 6 AM to 6 PM, and a lunch menu scheduled to run from 12 PM to 1 PM. When a call comes in at 12:30 PM, Interaction Attendant sees that the lunch menu was started more recently, and therefore uses the lunch menu. This "tie-breaker" also applies when there are conflicts between two weekly or monthly schedules.

Operations

Operations are actions that Interaction Attendant performs, usually in response to a user key press. Operations are added below schedule nodes to create menus. Operations are scoped to the server whose node is selected. For example, you can't use an operation to transfer a call to a workgroup on another server. Interaction Attendant provides operations for each object type (telephone calls and Emails):

Object Types

- [Call Operations](#)
- [Email Operations](#)

Call Operations

Attendant provides many call operations, so we have categorized them into related groups:

- [Standard](#) operations perform ordinary IVR actions, such as dialing by name, dialing an extension, or transferring the call.
- [Database](#) operations query a database and can play back a field to the caller using text-to-speech. These nodes can also insert a new row, or update a database field.
- [Queue](#) operations interact with callers who are waiting in queues, by playing messages, presenting menus, or allowing the caller to request a callback.

Standard Operations

Standard Operations perform ordinary IVR actions, such as dialing by name, dialing an extension, or transferring the call.

[Caller Data Entry](#)

Prompts callers to enter a string of digits.

[Dial by Name](#)

Prompts a caller to enter the first few digits of an Interaction Client user's first or last name.

[Dial Extension](#)

Dial Extension transfers a call to the extension of an Interaction Client user. The caller, who must know the number beforehand, enters the extension number.

[Disconnect](#)

This operation provides callers with a graceful way to exit a menu system.

[Disposition Interaction Dialer Call](#)

This operation dispositions an Outbound call that was placed by Interaction Dialer. You can assign Reason and Finish codes to classify the call for reporting purposes, and then disconnect or transfer the call to a menu, profile, or operator call flow.

[Fax Back](#)

Sends a FAX to a caller's FAX machine.

[Language Selection](#)

Sets the [current language](#) used to play back prompts in other menus.

[Logging](#)

Logging appends information to the call's Interaction Log. Agents can view this information in Interaction Client to reveal the path that the call took through Attendant. This helps the agent to discern what the caller is looking for without having to ask the caller questions.

[Logical Transfer](#)

Uses a logical expression to decide which node to transfer control to.

[Multi-Action Container](#)

A Multi-Action node groups related steps of a process together to create a call flow routine. This node does not perform any actions itself. It is a container for other nodes that perform related actions of some sort.

[Other Tools](#)

This operation is available exclusively in editions of the CIC that do not include Interaction Designer for handler customizations. It allows you to execute predefined [handlers](#) by selecting them from a combo box.

[Play a Menu](#)

Presents a menu of choices to the caller.

[Play Audio](#)

Plays a wave audio (.wav) file for the caller. This form provides audio controls that help administrators select, record, or playback message prompts.

[Play Info](#)

The *Play Info* action plays wave audio files like the Play Audio action, but adds the ability to play audio containing information retrieved from call attributes. You can specify an ordered sequence of audio bits to be played. Each audio bit can consist of an audio wav file followed by audio generated from a specified call attribute.

[Receive Fax](#)

Prompts a caller to press start on a FAX machine.

[Remote Access](#)

Allows a caller to retrieve voice mail from a remote location, to change status, or manage recorded prompts.

[Remote Data Query](#)

The Remote Data Query action calls a web service to retrieve data returned in call attributes.

[Run Subroutine](#)

Runs a custom [handler](#).

[Run Voicebot](#)

Allows a Voicebot to take over the processing of an interaction.

[Screen Pop](#)

Screen Pop executes an action previously configured using the *Actions* container in Interaction Administrator. Actions can be thought of as a direct communications link between two application programs. Data is passed to a third party application to perform some action. For example, a URL can be passed to a web browser. In Attendant, a profile can be set up to invoke a screen pop action.

[Selection](#)

A Selection action branches after evaluating one or more expression cases. This action is similar to a Logical Transfer, but easier to set up when multiple expression cases must be evaluated.

[Set Attribute](#)

Attaches an attribute to the call object.

[Transfer to a Different Menu](#)

Transfers a call to another menu within the same profile or another profile.

[Transfer to a Workgroup or Station Group](#)

Transfers a call to a specific workgroup or station group. Station groups are groups of phones in break rooms, conference rooms, and other public areas.

[Transfer to an Agent](#)

Sends a call to a specific [user queue](#) or [station queue](#).

[Transfer to an External Number](#)

Transfers a call to a telephone number outside of your organization.

[Transfer to Voicemail](#)

Transfers a call to the voice mailbox of the user or workgroup queue you specify.

[Transfer to an Attendant Profile](#)

Transfers the current call to any inbound, outbound, or operator profile defined for this server.

>>>> ORIGINAL //eic/2021r2_systest/products/documentation/source/Attendant/standard_operations.htm#2

[Voicebot](#)

Voicebot integrate with the bots like Google Dialogflow via Genesys Cloud.

==== THEIRS //eic/2021r2_systest/products/documentation/source/Attendant/standard_operations.htm#3

Add inbound IVR surveys to Interaction Attendant profiles

You can create an on-demand survey in Interaction Feedback and initiate it within an Interaction Attendant profile. Such surveys do not require agent interaction. Examples of such surveys include employee satisfaction requests solicited via coupon validation codes and mandatory health management surveys from outsourced health care providers to ensure patient benefit retention. These surveys allow companies to measure satisfaction and improve service.

A designated Interaction Feedback administrator creates the survey through Interaction Center Business Manager. Obtain the name of the survey you want to add to the Interaction Attendant profile before you begin.

Note: The survey must be marked as Active in Interaction Feedback in order to be available for use in Interaction Attendant.

To add an inbound IVR survey to a profile:

1. Do one of the following to open the Survey1 form:
 - Open the **Insert** menu and select **Present Survey**.
 - Click the  button in the Interaction Attendant toolbar.
2. In the **Node Characteristics** area, complete the following:

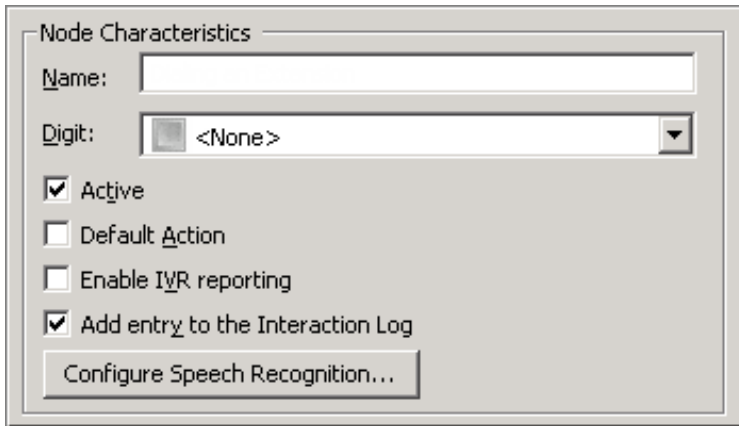

The screenshot shows a dialog box titled "Node Characteristics". It has a "Name:" text input field. Below it is a "Digit:" dropdown menu currently showing "<None>". There are four checkboxes: "Active" (checked), "Default Action" (unchecked), "Enable IVR reporting" (unchecked), and "Add entry to the Interaction Log" (checked). At the bottom is a button labeled "Configure Speech Recognition...".

Name field

The name of the survey. The label you enter here becomes the name of the node in the tree structure.

Digit list box

Use this list to select the key that callers press to enter a caller data entry operation. When you assign a digit, the list displays only available digits—those that are not already in use at this level of the tree. If no digit is assigned, callers cannot invoke the operation directly. It is possible to create menu options that are invoked by a routing process, rather than by a user selection. For details, see [invoke a menu operation automatically](#).

Active check box

By default, forms are "on", or "active", which means that Interaction Attendant will process them. If you uncheck a form's Active check box, the name of the node turns gray in the tree to indicate that the form is inactive. Interaction Attendant and its [handlers](#) will thereafter ignore the form and its children. Use this feature to save a configuration that you are testing. Inactive forms are invisible to callers. When a node is inactive, it appears grayed out in the tree view.

Default Action check box

At any given "level" in the tree structure, one node can be marked as the default action. The operation defined by the [default node](#) is performed if the caller does not press a key within the timeout period specified by that menu. The icon for default forms has a green border in the tree structure. Any node below a menu or schedule can be marked as the [default action](#), by checking the form's default action check box.

Enable IVR Reporting

This option determines whether or not reporting data will be collected when control passes through this node. Several IVR Reports summarize this information. IVR Reporting is *disabled* by default. Enable it to capture the date, time and duration of time that the call remained in the node and its children. This option is hidden when Attendant is connected to a server that does not have reporting installed. For more information about this feature, see [IVR Reporting Option](#).

Add entry to the Interaction Log

When this option is enabled, information about this node is appended to the call's Interaction Log when the call enters this node. This helps track the path that a call took through Attendant. The Interaction Log is maintained for reporting purposes. See [View the Interaction Log](#) for details.

Configure Speech Recognition... button

Select this button to configure words or phrases that can be associated with menu options. Callers can verbally indicate the options they want in the IVR instead of pressing a digit on the phone. You can enter multiple words and phrases for each menu item, just as callers may phrase the same request in different ways. For example, "transfer funds" or "funds transfer". See [Add Speech Recognition keywords or phrases to Inbound Call Operations](#).

3. In the **Survey** drop-down list, select the IVR survey you wish to use in this profile.

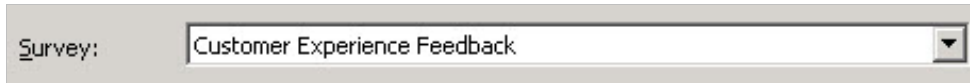

4. Click **Save** to publish the changes to the profile.

Caller Data Entry

Caller Data Entry prompts callers to enter a string of digits using their telephone keypad. For example, it might ask a caller to enter a FAX number or an account number. User input ends after a specified number of digits are received, or when a terminating character is received. You have the option to convert the entry to speech, and read it back to the caller. The input data can also be attached to the call object as a call object attribute. Call object attributes can be used in DDE operations, and may be accessed by [handlers](#). Data attached to a call is sometimes used in screen pops.

Understanding How Timeout Behavior is Calculated

If a user presses the key specified in the Digit list box, he or she has a predetermined amount of time to enter subsequent numbers before the system times out. The system also times out after a set period if a user enters less than the specified number of digits set in the End of Input Condition frame and does not enter a terminating character. Interaction Attendant will wait twice the set timeout value to receive the first digit and waits the exact timeout value for all subsequent digits. For example, if the timeout value is set to 3 seconds, the system will wait 6 seconds to receive the first digit, and will wait three seconds to receive each subsequent digit.

If Speech Recognition is enabled on the Caller Data Entry node, Interaction Attendant will wait four times the set timeout value to receive the first digit and waits the exact timeout value for all subsequent digits. Use the **Reco Input Timeout Multiplier** server parameter to set a multiplier other than four if Speech Recognition is enabled.

Note: Timeout values are set in the [Caller Data Entry Error Handling Options Dialog](#).

You can determine the flow of control that occurs after data entry has been completed. For example, you can return to the previous menu, disconnect the call, or jump to any profile, schedule, menu, or operation. However, control cannot be passed to a profile, schedule, menu, or to an operation on another server.

In-Queue menus

You can place the **Caller Data Entry** node within an in-queue menu. When you also add a **Request Callback** node to the in-queue menu, you can configuring the **Caller Data Entry** node's **Action When Finished** frame to jump to the in-queue menu's **Request Callback** node. This configuration lets the caller enter a specific telephone number during a callback request, and Interaction Attendant will pull that number from the Caller Data Entry node when processing the callback request.

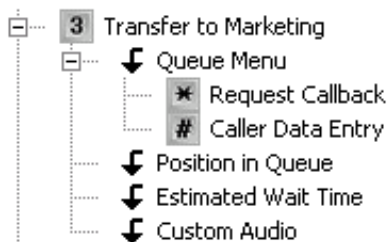

Note: Make sure you also configure the **Request Callback** node's **Callback Number** frame to call the appropriate **Caller Data Entry** node listed in the in-queue menu.

You can also configure a **Caller Data Entry** node within an in-queue menu to jump to another in-queue menu. To transfer to a

menu under the same **Group Transfer** node, set the **Allow Relocation to Other In-Queue Node** server parameter to **True**. The **Caller Data Entry** node does not support jumping:

- From an in-queue caller data entry to a different in-queue operation under a different group transfer.
- Directly to a node under a different in-queue menu.

Node Characteristics frame

Options in this frame name the node, assign the digit used to select it, and establish whether or not it is active, used by default, logged, or tracked for reporting purposes.

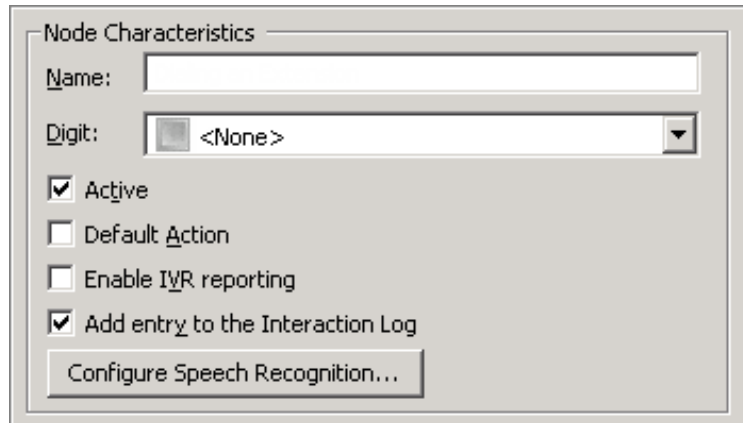

The screenshot shows a dialog box titled "Node Characteristics". It has a "Name:" text input field. Below it is a "Digit:" dropdown menu currently showing "<None>". There are four checkboxes: "Active" (checked), "Default Action" (unchecked), "Enable IVR reporting" (unchecked), and "Add entry to the Interaction Log" (checked). At the bottom is a button labeled "Configure Speech Recognition...".

Name field

The label you enter here becomes the name of the node in the tree structure.

Digit list box

Use this list to select the key that callers press to enter a caller data entry operation. When you assign a digit, the list displays only available digits—those that are not already in use at this level of the tree. If no digit is assigned, callers cannot invoke the operation directly. It is possible to create menu options that are invoked by a routing process, rather than by a user selection. For details, see [invoke a menu operation automatically](#).

Active check box

By default, forms are "on", or "active", which means that Interaction Attendant will process them. If you uncheck a form's Active check box, the name of the node turns gray in the tree to indicate that the form is inactive. Interaction Attendant and its [handlers](#) will thereafter ignore the form and its children. Use this feature to save a configuration that you are testing. Inactive forms are invisible to callers. When a node is inactive, it appears grayed out in the tree view.

Default Action check box

At any given "level" in the tree structure, one node can be marked as the default action. The operation defined by the [default node](#) is performed if the caller does not press a key within the timeout period specified by that menu. The icon for default forms has a green border in the tree structure. Any node below a menu or schedule can be marked as the [default action](#), by checking the form's default action check box.

Enable IVR Reporting

This option determines whether or not reporting data will be collected when control passes through this node. Several IVR Reports summarize this information. IVR Reporting is *disabled* by default. Enable it to capture the date, time and duration of time that the call remained in the node and its children. This option is hidden when Attendant is connected to a server that does not have reporting installed. For more information about this feature, see [IVR Reporting Option](#).

Add entry to the Interaction Log

When this option is enabled, information about this node is appended to the call's Interaction Log when the call enters this node. This helps track the path that a call took through Attendant. The Interaction Log is maintained for reporting purposes. See [View the Interaction Log](#) for details.

Configure Speech Recognition... button

Select this button to configure words or phrases that can be associated with menu options. Callers can verbally indicate the options they want in the IVR instead of pressing a digit on the phone. You can enter multiple words and phrases for each menu item, just as callers may phrase the same request in different ways. For example, "transfer funds" or "funds transfer". See [Add Speech Recognition keywords or phrases to Inbound Call Operations](#).

Prompt frame

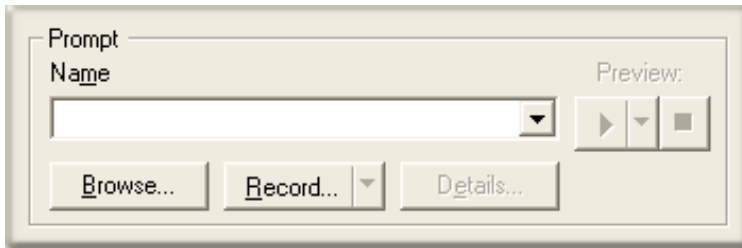

Controls in this frame set a prompt to play when control is passed to this node. If you do not select or record a prompt using the [embedded audio controls](#), no voice prompting will occur. See [manage voice prompts](#) for details.

Use speech recognition for the data entry



Select this check box to allow callers to speak the numbers instead of manually entering them.

End of Input Condition frame

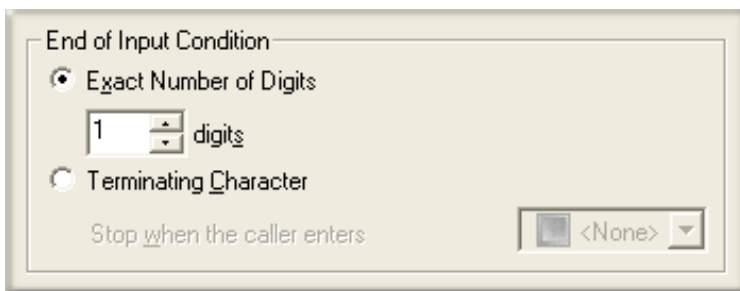

The options in this frame determine what signals Attendant to stop listening for incoming digits. You can end the data entry process when a fixed number of digits are received, or stop accepting data once a terminating character is pressed.

Exact number of digits

This radio button enables the *digits* spin control. Data acquisition is terminated once the number of digits that you select are received.

Terminating Character

This radio button enables the *Stop when caller enters* combo box, so that you can select the value that will be used to signal end of data entry. The possible values are 0-9, #, and *. <None> is also an option, but you should never use it. If you do, Attendant will never stop accepting data.

Verification frame

Options in the *Verification* frame control feedback given to callers about data entered.

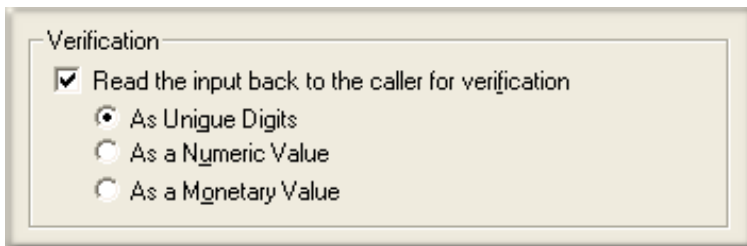

Read the input back to the caller for verification check box

When verification is enabled, data entered by the caller is converted to speech and is read back to the caller. Afterwards, Attendant prompts the caller to confirm or reject the entry:

- "If this is the desired entry, press 1. Otherwise to reenter, press 2."
- If the caller selects 1, the input data is accepted. If the caller presses 2, the caller is prompted to reenter the data. The radio buttons control the way in which numeric input data is pronounced by the text-to-speech engine:

As Unique Digits radio button

1234 will be read back as "one two three four".

As a Numeric Value radio button

1234 will be read back as one thousand, two hundred and thirty four".

As a Monetary Value radio button

1234 will be read back as "twelve hundred thirty four dollars". Since the caller data entry operation does not provide a way to delimit dollars and cents, it doesn't offer a built-in method of capturing decimal numbers. However, you could use two caller data entry operations; one to capture the whole dollar amount, and another to capture the cents.

If the verification option is unchecked, no data is read back to the caller, and confirmation prompting does not occur. It's a good idea to provide callers with the ability to accept or reject data entered. You should always enable verification unless you are prompting for simple 1-digit values (e.g. 1=Yes, 2=No).

Call Attribute frame

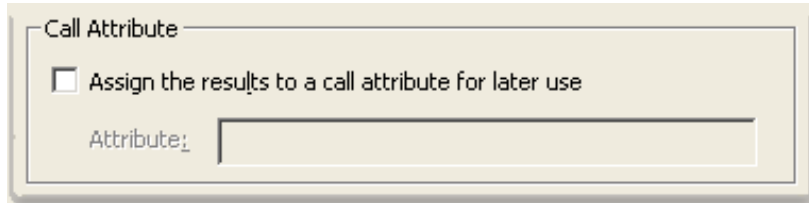

You can attach data entered by the caller to the call itself as a *call attribute*. An attribute is a piece of information about an object that travels with it throughout the Customer Interaction Center. For example, one standard attribute of a call object is the telephone number of the person who placed the call. A call object can have as many attributes as are needed. Attributes stay with a call until it is disconnected.

CIC supports application programming interfaces (API's) that provide access to call object attributes. Dynamic Data Exchange (DDE) is commonly used to accomplish this, as is the Interaction Client Win32 COM API. Attributes typically store information that is passed to a database or a third-party application. For example, the IC can be set up to "pop" a database application when an incoming call arrives at an agent's workstation.

Related Documentation

For more information about DDE and other APIs, see the *System APIs* section of the master documentation library on your IC server. The *Interaction Attributes Technical Reference* (in the PureConnect Documentation Library) describes attribute names that are reserved by IC. If you assign data to a standard IC attribute, you could potentially affect the execution of a handler. The *Interaction Attributes Technical Reference* identifies attributes whose value you should never change.

Suppose, for example, that you use caller data entry to capture an account number and store it as a call attribute. This preserves the account number as the call is routed throughout CIC. If the call is routed to an agent's desktop, the account number can be used to look up the customer record in a database. Information about the customer can be displayed on the screen at the time when an agent receives the call.

Assign the results to a call attribute for later use

Enable this check box to assign data entered by the caller to a call attribute. Each call attribute is a name/value pair. The attribute name can be anything you like, since it identifies the data.

Attribute

This field stores the name of the attribute that input data will be assigned to. Since many handlers in CIC process attributes, attribute names have been standardized to identify common types of data. Type the name of a standard call attribute in this field, or enter your own custom attribute name.

You can name a custom attribute anything you like. Custom names can contain spaces and special characters. To avoid potential conflicts with reserved attribute names, do not begin the name with the letters EIC_. CIC's standard attribute names begin with those letters. If you overwrite a standard attribute, you could accidentally interfere with normal operation of the IC server.

Advanced Error Handling Options

Advanced Error Handling...

The Caller Data Entry form provides advanced error handling options that supplement the error handling provided by the schedule that the form is attached to. To define these options, press the *Advanced Error Handling* button.

Advanced Error Handling button

Opens the [Caller Data Entry Error Handling Options Dialog](#). It defines the maximum length of time that Interaction Attendant should wait for keys to be pressed before re-prompting the caller, and establishes the maximum number of times that the prompt will be repeated before control is passed to the Schedule's error handler, or to the [profile](#), [schedule](#), [menu](#), or [operation](#) that you select.

Action When Finished frame

These options set the processing that occurs after the operation completes successfully, when flow of control leaves this node. You can return control to the previous menu, disconnect the call, transfer to an operator profile, or jump to any node or

action that has been defined for the current server.

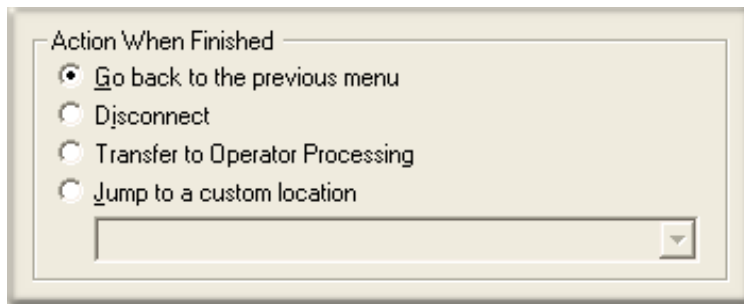

Go back to previous menu

This option returns control to the parent menu. This sets up a simple loop that "reruns" the menu from the top.

Disconnect

This option disconnects the call when the data entry operation is completed successfully.

Transfer to Operator Processing

Transfers the call for evaluation by operator profiles defined for this server.

Jump to a custom location

This option allows you to jump to any [profile](#), [schedule](#), [menu](#), or [operation](#) that is defined for the current server.

Dial by Name

Dial by name allows a caller to find an agent by name. It prompts a caller to enter the first few digits of an Interaction Client user's first or last name. The digits can be compared to first name only, last name only, or to both first and last names. Matching can be restricted to selected workgroups, or to the entire company directory. You can match after a specific number of characters, or wait until the user enters a unique match.

- If a single match is found, the caller can press 1 to call the extension. If more than one match is found, Interaction Attendant plays each name and extension, and then allows the caller to enter the correct extension.
- If no matches are found, a prompt explains this to the caller. Interaction Attendant returns to the menu from which Dial by Name was called.
- The matching style is configurable. You can require a unique match, or can approve a match based upon a defined number of matching characters.

Essential Guidelines for using the Dial by Name Action

Due to a limitation in handler logic, ASR Speech Recognition does not work properly unless:

- The Dial by Name action is attached to a **Schedule**. Speech Recognition isn't used if the Dial by Name node is placed under a menu instead of a schedule.
- The Schedule's "**Number of Seconds to wait before repeating**" setting is greater than 0 seconds.

Node Characteristics frame

Options in this frame name the node, assign the digit used to select it, and establish whether or not it is active, used by default, logged, or tracked for reporting purposes.

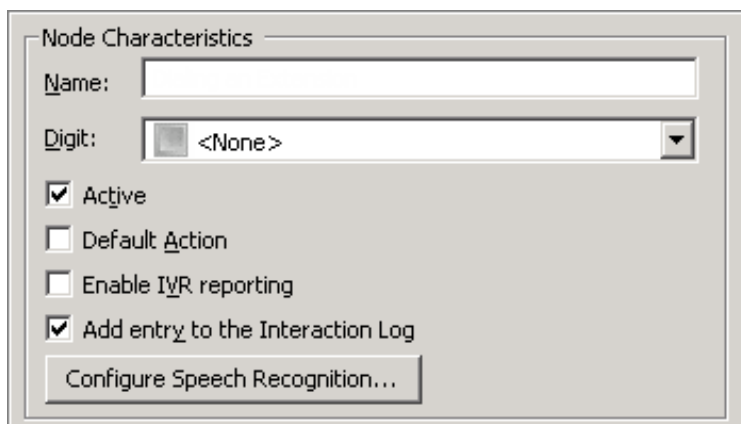

Name field

The label you enter here becomes the name of the node in the tree structure.

Digit list box

Use this list to select the key that callers press to enter a caller data entry operation. When you assign a digit, the list displays only available digits—those that are not already in use at this level of the tree. If no digit is assigned, callers cannot invoke the operation directly. It is possible to create menu options that are invoked by a routing process, rather than by a user selection. For details, see [invoke a menu operation automatically](#).

Active check box

By default, forms are "on", or "active", which means that Interaction Attendant will process them. If you uncheck a form's Active check box, the name of the node turns gray in the tree to indicate that the form is inactive. Interaction Attendant and its [handlers](#) will thereafter ignore the form and its children. Use this feature to save a configuration that you are testing. Inactive forms are invisible to callers. When a node is inactive, it appears grayed out in the tree view.

Default Action check box

At any given "level" in the tree structure, one node can be marked as the default action. The operation defined by the [default node](#) is performed if the caller does not press a key within the timeout period specified by that menu. The icon for default forms has a green border in the tree structure. Any node below a menu or schedule can be marked as the [default action](#), by checking the form's default action check box.

Enable IVR Reporting

This option determines whether or not reporting data will be collected when control passes through this node. Several IVR Reports summarize this information. IVR Reporting is *disabled* by default. Enable it to capture the date, time and duration of time that the call remained in the node and its children. This option is hidden when Attendant is connected to a server that does not have reporting installed. For more information about this feature, see [IVR Reporting Option](#).

Add entry to the Interaction Log

When this option is enabled, information about this node is appended to the call's Interaction Log when the call enters this node. This helps track the path that a call took through Attendant. The Interaction Log is maintained for reporting purposes. See [View the Interaction Log](#) for details.

Configure Speech Recognition... button

Select this button to configure words or phrases that can be associated with menu options. Callers can verbally indicate the options they want in the IVR instead of pressing a digit on the phone. You can enter multiple words and phrases for each menu item, just as callers may phrase the same request in different ways. For example, "transfer funds" or "funds transfer". See [Add Speech Recognition keywords or phrases to Inbound Call Operations](#).

Match By frame

These options determine what the digits entered by the caller are compared to.

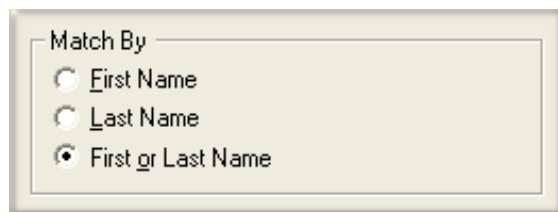
A screenshot of a web form titled "Match By". It contains three radio button options: "First Name", "Last Name", and "First or Last Name". The "First or Last Name" option is selected, indicated by a filled radio button.

First Name radio button

When this option is selected, user input is matched against the first names of Interaction Client users.

Last Name radio button

When this option is selected, user input is matched against the last names of Interaction Client users.

First or Last Name radio button

When this option is selected, user input is matched against the first and last names of Interaction Client users.

Matching Style

These options determine whether a complete matching is required.

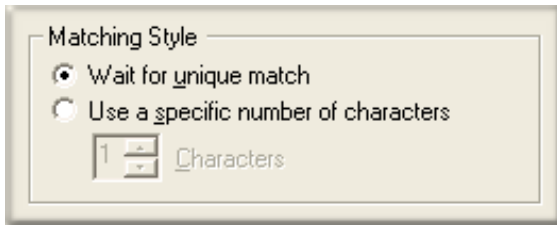

Wait for unique match

When selected, users must enter characters until a unique match is found.

Use a specific number of characters

When selected, enables the *number of characters* spin control, which sets the number of matching characters that users must enter before matches are evaluated.

Filtering

These options determine whether digits entered by the caller are compared to the entire company directory or to specific workgroups.

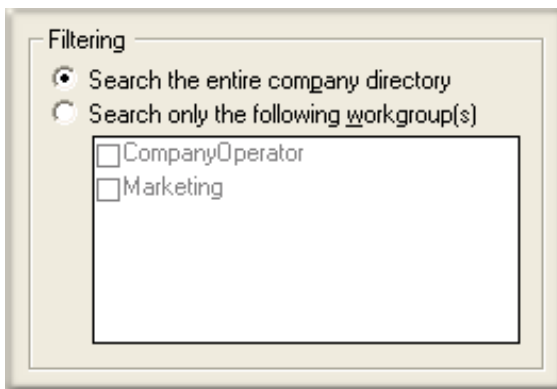

Search entire directory

Check *Search the entire company directory* to match user input against all names in the company directory.

Search only the following workgroups

Check *Search only the following workgroups* to restrict matching to the workgroups whose name are checked in the workgroups list.

Workgroups list

The names of workgroups appear in this list box. Check or uncheck workgroup names in this list to include or exclude them from workgroup searches.

Dial Extension

This operation allows the caller to dial and be transferred to a specific extension. The caller, who must know the number beforehand, enters the extension number. Matching can be restricted to selected workgroups, or to the entire company directory.

The extension can be an Interaction Client user's extension, a workgroup extension, or a workstation extension. The call is then transferred to that extension, or a prompt is played if the extension is not valid. If the extension is valid, the call is transferred. If the extension is not valid, the caller is returned to the menu from which Dial Extension was called. Interaction Attendant's [handlers](#) listen for digits entered by the caller. You are responsible for setting up a voice prompt that is played when a user does not respond within a specified time period.

Dial Extension entries can be a little tricky to set up, so be sure to read this topic carefully. Like most auto-attendants, Dial Extension allows callers to dial an extension as soon as the call is picked up. For example, when the call is picked up and the prompt says "Welcome to Acme Explosives Corporation" the caller can dial 123 to call extension 123 without navigating your entire menu structure.

To enable this functionality, you will need to know the number used to begin all extensions. For example, all extensions in your company could begin with a 1, 7, or 8. Individual extensions start with a 1, such as 114, 133, or 155. Workgroup extensions start with a 7, such as 701 for sales and 702 for support. And workstation extensions begin with 8, such as 810 for the conference room and 825 for the shop floor.

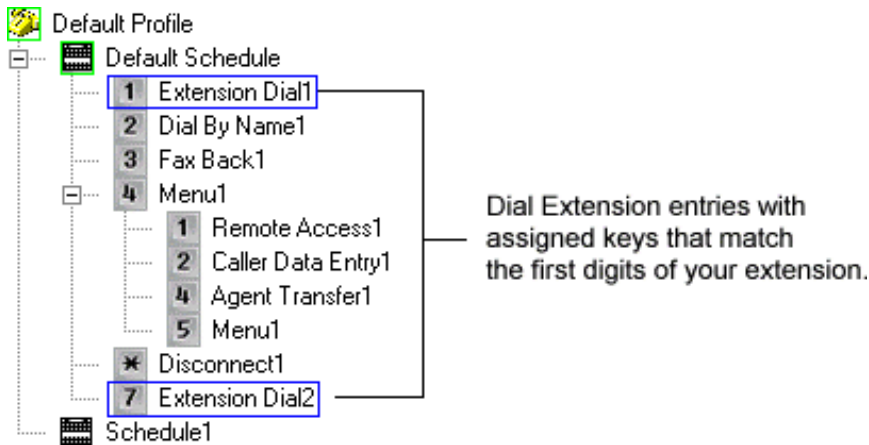

Once you've identified the numbers that start extensions, you should add an Dial Extension entry with an assigned key for each of these numbers. This is shown in the following diagram.

Once this is configured as described above, a caller dialing an extension will invoke the menu entry with the first key press. The Dial Extension entry knows that the caller is trying to dial an extension, recognizes that the first digit dialed was part of the extension, and uses that first digit and any following digits to determine the requested extension. It then looks up the extension and transfers the call, or plays an error message if the extension is invalid.

Node Characteristics frame

Options in this frame name the node, assign the digit used to select it, and establish whether or not it is active, used by default, logged, or tracked for reporting purposes.

Name field

The label you enter here becomes the name of the node in the tree structure.

Digit list box

Use this list to select the key that callers press to enter a caller data entry operation. When you assign a digit, the list displays only available digits—those that are not already in use at this level of the tree. If no digit is assigned, callers cannot invoke the operation directly. It is possible to create menu options that are invoked by a routing process, rather than by a user selection. For details, see [invoke a menu operation automatically](#).

Active check box

By default, forms are "on", or "active", which means that Interaction Attendant will process them. If you uncheck a form's Active check box, the name of the node turns gray in the tree to indicate that the form is inactive. Interaction Attendant and its [handlers](#) will thereafter ignore the form and its children. Use this feature to save a configuration that you are testing. Inactive forms are invisible to callers. When a node is inactive, it appears grayed out in the tree view.

Default Action check box

At any given "level" in the tree structure, one node can be marked as the default action. The operation defined by the [default node](#) is performed if the caller does not press a key within the timeout period specified by that menu. The icon for default forms has a green border in the tree structure. Any node below a menu or schedule can be marked as the [default action](#), by checking the form's default action check box.

Enable IVR Reporting

This option determines whether or not reporting data will be collected when control passes through this node. Several IVR Reports summarize this information. IVR Reporting is *disabled* by default. Enable it to capture the date, time and duration of time that the

call remained in the node and its children. This option is hidden when Attendant is connected to a server that does not have reporting installed. For more information about this feature, see [IVR Reporting Option](#).

Add entry to the Interaction Log

When this option is enabled, information about this node is appended to the call's Interaction Log when the call enters this node. This helps track the path that a call took through Attendant. The Interaction Log is maintained for reporting purposes. See [View the Interaction Log](#) for details.

Configure Speech Recognition... button

Select this button to configure words or phrases that can be associated with menu options. Callers can verbally indicate the options they want in the IVR instead of pressing a digit on the phone. You can enter multiple words and phrases for each menu item, just as callers may phrase the same request in different ways. For example, "transfer funds" or "funds transfer". See [Add Speech Recognition keywords or phrases to Inbound Call Operations](#).

Filtering frame

These options determine whether digits entered by the caller are compared to the entire company directory or to specific workgroups.

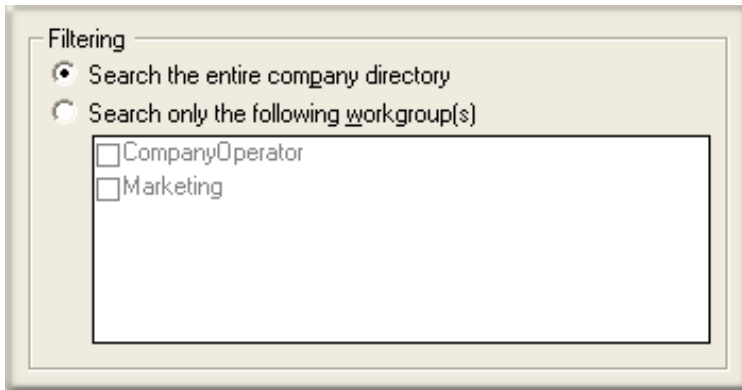

Search entire directory

Check *Search the entire company directory* to match user input against all names in the company directory.

Search only the following workgroups

Check *Search only the following workgroups* to restrict matching to the workgroups whose name are checked in the workgroups list.

Workgroups list

The names of workgroups appear in this list box. Check or uncheck items in this list to include or exclude them from workgroup searches.

Error Handling frame

These options tell Attendant what to do if the caller does not enter digits very quickly.

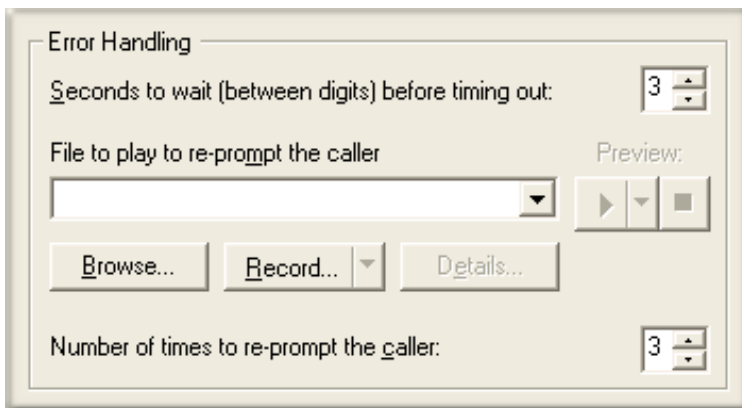

Seconds to wait (between digits) before timing out spin control

This control sets the amount of time, in seconds, that Attendant waits for the caller to press a key. If a timeout occurs, control is passed to the schedule's error handler. The caller will be re-prompted as per the re-prompt controls. After 'n' re-prompts the error handler is ignored.

File to play to re-prompt the caller list box

The [embedded audio controls](#) in this frame are used to select or record a voice prompt file that will play if the caller does not enter a digit within the period of time specified by *seconds to wait between digits before timing out*.

Number of times to re-prompt the caller

This spin control sets the number of chances that a caller has to enter a valid extension before control is passed to the schedule's error handler. After 'n' re-prompts the error handler is ignored.

Disconnect

Disconnect provides callers with a graceful way to exit a menu system. It disconnects the call immediately. It is good practice to provide a Disconnect option, so that callers will know when it is appropriate to hang up. You can optionally play a wave file before the call is disconnected (e.g. "thank you for calling"). This gives callers a way to say goodbye to the auto-attendant. If you leave callers in a menu that lacks an exit path, they may feel trapped, and may dislike the system.

Node Characteristics frame

Options in this frame name the node, assign the digit used to select it, and establish whether or not it is active, used by default, logged, or tracked for reporting purposes.

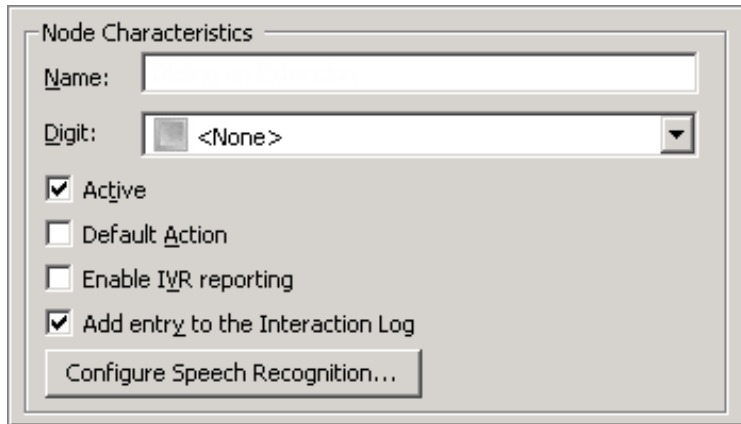

Name field

The label you enter here becomes the name of the node in the tree structure.

Digit list box

Use this list to select the key that callers press to enter a caller data entry operation. When you assign a digit, the list displays only available digits—those that are not already in use at this level of the tree. If no digit is assigned, callers cannot invoke the operation directly. It is possible to create menu options that are invoked by a routing process, rather than by a user selection. For details, see [invoke a menu operation automatically](#).

Active check box

By default, forms are "on", or "active", which means that Interaction Attendant will process them. If you uncheck a form's Active check box, the name of the node turns gray in the tree to indicate that the form is inactive. Interaction Attendant and its [handlers](#) will thereafter ignore the form and its children. Use this feature to save a configuration that you are testing. Inactive forms are invisible to callers. When a node is inactive, it appears grayed out in the tree view.

Default Action check box

At any given "level" in the tree structure, one node can be marked as the default action. The operation defined by the [default node](#) is performed if the caller does not press a key within the timeout period specified by that menu. The icon for default forms has a green border in the tree structure. Any node below a menu or schedule can be marked as the [default action](#), by checking the form's default action check box.

Enable IVR Reporting

This option determines whether or not reporting data will be collected when control passes through this node. Several IVR Reports summarize this information. IVR Reporting is *disabled* by default. Enable it to capture the date, time and duration of time that the call remained in the node and its children. This option is hidden when Attendant is connected to a server that does not have reporting installed. For more information about this feature, see [IVR Reporting Option](#).

Add entry to the Interaction Log

When this option is enabled, information about this node is appended to the call's Interaction Log when the call enters this node. This helps track the path that a call took through Attendant. The Interaction Log is maintained for reporting purposes. See [View the Interaction Log](#) for details.

Configure Speech Recognition... button

Select this button to configure words or phrases that can be associated with menu options. Callers can verbally indicate the options they want in the IVR instead of pressing a digit on the phone. You can enter multiple words and phrases for each menu item, just as callers may phrase the same request in different ways. For example, "transfer funds" or "funds transfer". See [Add Speech Recognition keywords or phrases to Inbound Call Operations..](#)

Audio File frame

The options in this frame manage an optional voice prompt that plays before the user is disconnected.

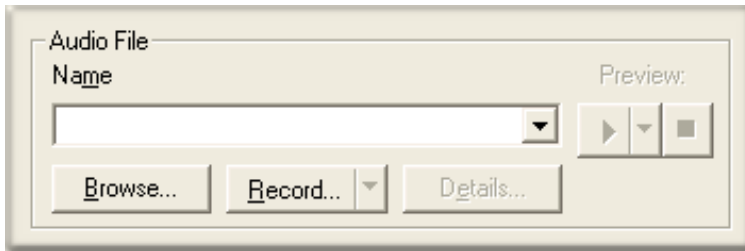

Name

This field stores the name of the prompt. See [Using embedded audio controls.](#)

Disposition Interaction Dialer Call

The ability to disposition an outbound call made by Interaction Dialer is available in outbound call flows only. You can assign Wrap-up categories and Wrap-up codes to classify the call for reporting purposes, and then disconnect or transfer the call to a menu, profile, or operator call flow.

In general, Wrap-up codes add granularity to reporting, while Wrap-up categories provide for standardized reporting across multiple campaigns. Attendant passes Wrap-up categories and Wrap-up codes back to Interaction Dialer when the call is completed.

Configure call disposition preferences in the **Dialer Call Completed** node.

Node Characteristics frame

Options in this frame name the node, assign the digit used to select it, and establish whether or not it is active, used by default, logged, or tracked for reporting purposes.

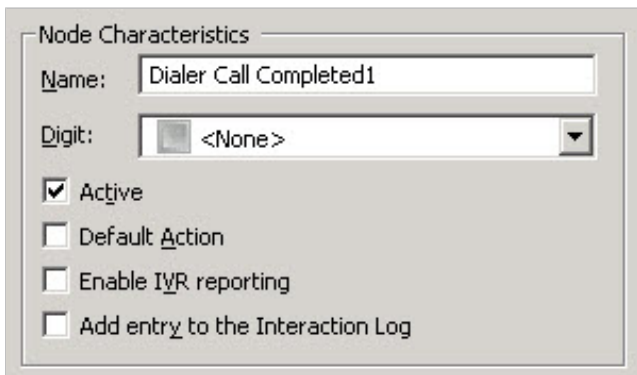

Name field

The label you enter here becomes the name of the node in the tree structure.

Digit list box

Use this list to select the key that callers press to enter a caller data entry operation. When you assign a digit, the list displays only available digits—those that are not already in use at this level of the tree. If no digit is assigned, callers cannot invoke the operation directly. It is possible to create menu options that are invoked by a routing process, rather than by a user selection. For details, see [invoke a menu operation automatically.](#)

Active check box

By default, forms are "on", or "active", which means that Interaction Attendant will process them. If you uncheck a form's Active check box, the name of the node turns gray in the tree to indicate that the form is inactive. Interaction Attendant and its [handlers](#) will thereafter ignore the form and its children. Use this feature to save a configuration that you are testing. Inactive forms are invisible to callers. When a node is inactive, it appears grayed out in the tree view.

Default Action check box

At any given "level" in the tree structure, one node can be marked as the default action. The operation defined by the [default node](#) is

performed if the caller does not press a key within the timeout period specified by that menu. The icon for default forms has a green border in the tree structure. Any node below a menu or schedule can be marked as the [default action](#), by checking the form's default action check box.

Enable IVR Reporting

This option determines whether or not reporting data will be collected when control passes through this node. Several IVR Reports summarize this information. IVR Reporting is *disabled* by default. Enable it to capture the date, time and duration of time that the call remained in the node and its children. This option is hidden when Attendant is connected to a server that does not have reporting installed. For more information about this feature, see [IVR Reporting Option](#).

Add entry to the Interaction log

When this option is enabled, information about this node is appended to the call's Interaction Log when the call enters this node. This helps track the path that a call took through Attendant. The Interaction Log is maintained for reporting purposes. See [View the Interaction Log](#) for details.

Configure Speech Recognition... button

Select this button to configure words or phrases that can be associated with menu options. Callers can verbally indicate the options they want in the IVR instead of pressing a digit on the phone. You can enter multiple words and phrases for each menu item, just as callers may phrase the same request in different ways. For example, "transfer funds" or "funds transfer". See [Add Speech Recognition keywords or phrases to Inbound Call Operations](#).

Wrap-up Category drop-down list

Wrap-up categories generically classify the result of a campaign call for reporting purposes. Interaction Dialer creates a set of wrap-up categories during installation, but you can also create your own. Any pre-defined wrap-up category may be used, and the category properties determine how Dialer interprets the results of the call.



Wrap-up Code drop-down list

Your CIC administrator can associate wrap-up codes with any workgroup queue. Wrap-up codes indicate the nature of an interaction; for example, a billing problem, a new order, or a service request. Your CIC administrator can generate reports to categorize call details by wrap-up codes.

Each campaign may have its own set of custom wrap-up codes. Wrap-up codes categorize the result of a call for reporting purposes, but are more specific than wrap-up categories. For example, a newspaper campaign might use wrap-up codes to record reasons given by customers for not subscribing. These wrap-up codes might be: "doesn't read a newspaper", "subscribes to a different newspaper", or something similar. The corresponding wrap up category would be "Failure", which is much less specific.

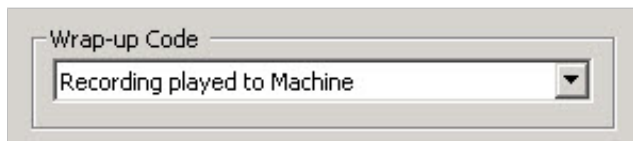

Action When Finished frame

These options set the processing that occurs after the operation completes successfully, when flow of control leaves this node. You can return control to the previous menu, disconnect the call, transfer to an operator profile, or jump to any node or action that has been defined for the current server.

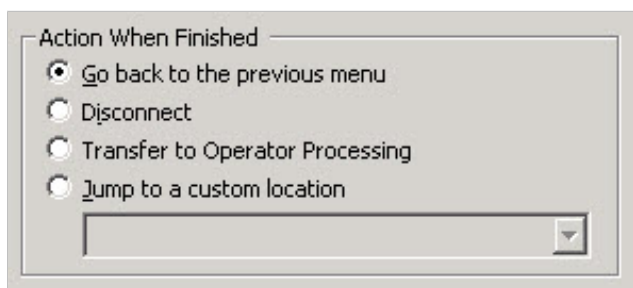

Go back to the previous menu radio button

This option returns control to the parent menu from which the message was played. This sets up a simple loop that "reruns" the parent menu from the top.

Disconnect radio button

This option disconnects the call.

Transfer to Operator Processing radio button

Transfers the call for evaluation by operator profiles defined for this server.

Jump to a custom location radio button

The *Jump to a custom location* radio button allows you to jump to any [profile](#), [schedule](#), [menu](#), or [operation](#) that is defined for the current server.

Fax Back

This operation sends a Fax to the number specified by the caller. The Fax is sent over the current call connection, or to the telephone number acquired by a [Caller Data Entry](#) node. Fax Back does not prompt the caller to enter a number. You must also specify which file to Fax, and the action to perform when finished.

Node Characteristics frame

Options in this frame name the node, assign the digit used to select it, and establish whether or not it is active, used by default, logged, or tracked for reporting purposes.

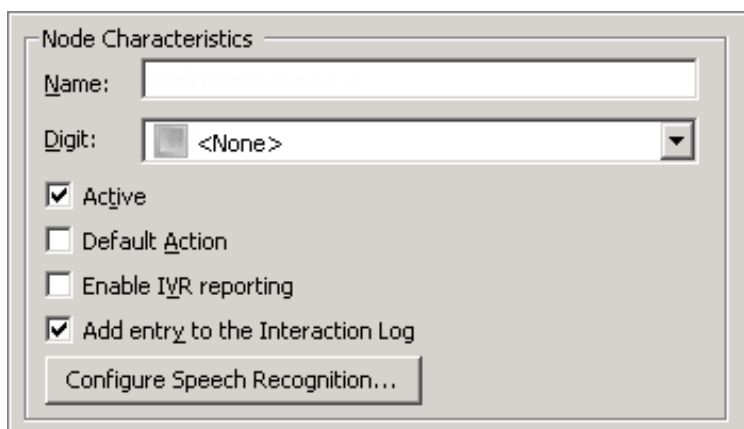

The image shows a dialog box titled "Node Characteristics". It contains the following elements:

- Name:** A text input field.
- Digit:** A dropdown menu currently showing "<None>".
- Active:** A checked checkbox.
- Default Action:** An unchecked checkbox.
- Enable IVR reporting:** An unchecked checkbox.
- Add entry to the Interaction Log:** A checked checkbox.
- Configure Speech Recognition...** A button.

Name field

The label you enter here becomes the name of the node in the tree structure.

Digit list box

Use this list to select the key that callers press to enter a caller data entry operation. When you assign a digit, the list displays only available digits—those that are not already in use at this level of the tree. If no digit is assigned, callers cannot invoke the operation directly. It is possible to create menu options that are invoked by a routing process, rather than by a user selection. For details, see [invoke a menu operation automatically](#).

Active check box

By default, forms are "on", or "active", which means that Interaction Attendant will process them. If you uncheck a form's Active check box, the name of the node turns gray in the tree to indicate that the form is inactive. Interaction Attendant and its [handlers](#) will thereafter ignore the form and its children. Use this feature to save a configuration that you are testing. Inactive forms are invisible to callers. When a node is inactive, it appears grayed out in the tree view.

Default Action check box

At any given "level" in the tree structure, one node can be marked as the default action. The operation defined by the [default node](#) is performed if the caller does not press a key within the timeout period specified by that menu. The icon for default forms has a green border in the tree structure. Any node below a menu or schedule can be marked as the [default action](#), by checking the form's default action check box.

Enable IVR Reporting

This option determines whether or not reporting data will be collected when control passes through this node. Several IVR Reports summarize this information. IVR Reporting is *disabled* by default. Enable it to capture the date, time and duration of time that the call remained in the node and its children. This option is hidden when Attendant is connected to a server that does not have reporting installed. For more information about this feature, see [IVR Reporting Option](#).

Add entry to the Interaction Log

When this option is enabled, information about this node is appended to the call's Interaction Log when the call enters this node. This helps track the path that a call took through Attendant. The Interaction Log is maintained for reporting purposes. See [View the Interaction Log](#) for details.

Configure Speech Recognition... button

Select this button to configure words or phrases that can be associated with menu options. Callers can verbally indicate the options they want in the IVR instead of pressing a digit on the phone. You can enter multiple words and phrases for each menu item, just as callers may phrase the same request in different ways. For example, "transfer funds" or "funds transfer". See [Add Speech Recognition keywords or phrases to Inbound Call Operations](#).

File to Fax frame

This section identifies the file to Fax.

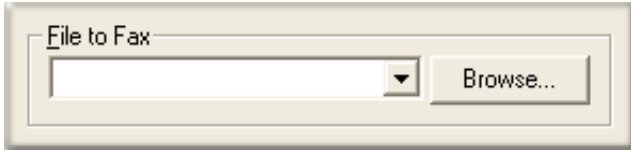

File to Fax

Selects an existing Interaction Fax file from the AttendantFaxes share on the CIC server. Fax files are created outside of Attendant using the Interaction Fax application.

Browse button

You can browse for *.i3f files anywhere on your network. When the configuration is published, the selected file is stored in the AttendantFaxes share on the CIC server.

Caller's Fax Number frame

These options control Fax routing.

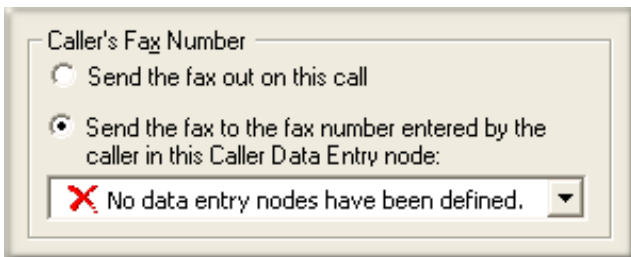

Send the fax out on this call radio button

This option determines whether the Fax will be sent using the current call connection, or by placing a new call once the current call is disconnected.

Send the fax to the fax number entered by the caller in this Caller Data Entry node:

This option identifies the [Caller Data Entry](#) node that acquires the destination telephone number to Fax. The Fax Back operation itself does not prompt the user to enter a telephone number. You must collect this information using a Caller Data Entry node before invoking Fax Back.

Action When Finished frame

These options set the processing that occurs after the operation completes successfully, when flow of control leaves this node. You can return control to the previous menu, disconnect the call, transfer to an operator profile, or jump to any node or action that has been defined for the current server.

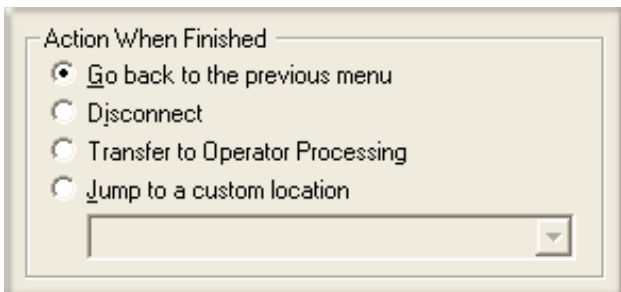

Go back to the previous menu radio button

This option returns control to the parent menu from which the message was played. This sets up a simple loop that "reruns" the parent menu from the top.

Disconnect radio button

This option disconnects the call once the FAX is sent.

Transfer to Operator Processing radio button

Transfers the call for evaluation by operator profiles defined for this server.

Jump to a custom location radio button

The *Jump to a custom location* radio button allows you to jump to any [profile](#), [schedule](#), [menu](#), or [operation](#) that is defined for the current server.

Language Selection

Language Selection operations create menus that allows callers to select a preferred language. This node sets the language used to play back prompts in other menus, overriding the default language, and setting a new current language. The example below allows callers to choose the language used to play back prompts in the Main Menu.

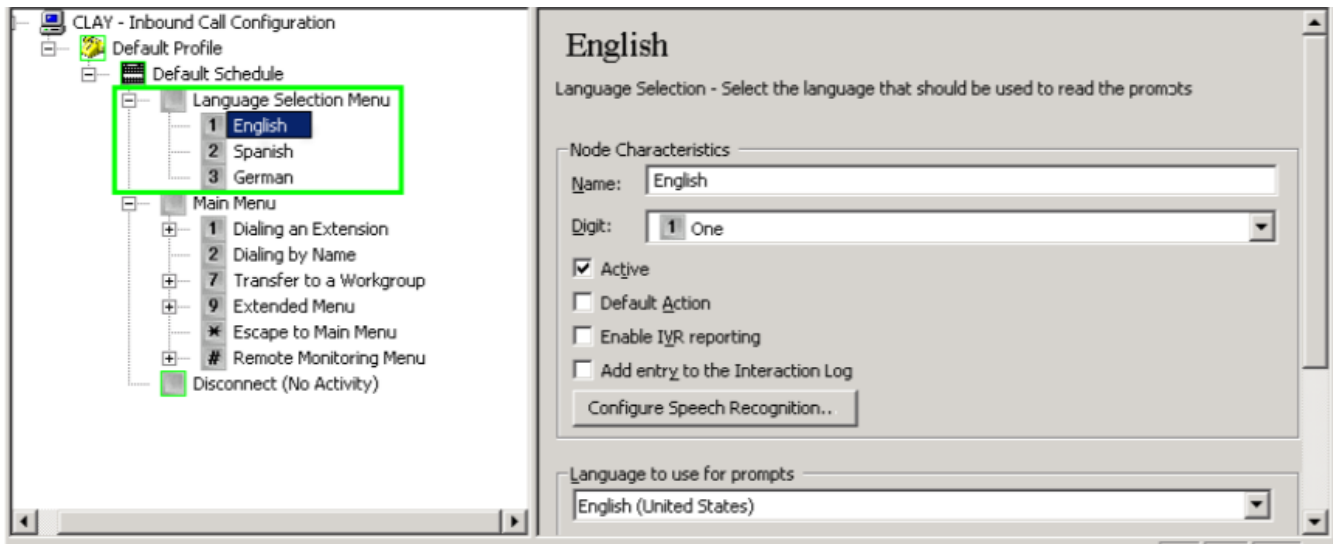

The language used to play prompts at runtime is known as the *current language*. The *default language* is defined outside of Interaction Attendant in Interaction Administrator. When you record a new prompt, Attendant assumes that you are recording in the default language defined for the server. Prompts are played in the default language unless the current language is set to something else by a language selection node or a profile form. See [manage voice prompts](#) for more information about mechanisms in Attendant that support multiple languages.

To Create a Language Selection Menu

Follow these steps to create a language selection menu.

1. Add a new menu node by selecting Insert | New Operation | Play a Menu. This menu should play a wave file that prompts users to select a language. e.g.: "Press 1 for English, Press 2 for French", etc.
2. Add a Language Selection node to the menu.
3. Assign a digit, pick a language from the combo box, and set up an action when finished. In most cases you will want to transfer control to another menu, as shown in the example above.
4. Repeat steps 2-3 to add additional language choices as needed.

Node Characteristics frame

Options in this frame name the node, assign the digit used to select it, and establish whether or not it is active, used by default, logged, or tracked for reporting purposes.

Name field

The label you enter here becomes the name of the node in the tree structure.

Digit list box

Use this list to select the key that callers press to enter a caller data entry operation. When you assign a digit, the list displays only available digits—those that are not already in use at this level of the tree. If no digit is assigned, callers cannot invoke the operation directly. It is possible to create menu options that are invoked by a routing process, rather than by a user selection. For details, see [invoke a menu operation automatically](#).

Active check box

By default, forms are "on", or "active", which means that Interaction Attendant will process them. If you uncheck a form's Active check box, the name of the node turns gray in the tree to indicate that the form is inactive. Interaction Attendant and its [handlers](#) will thereafter ignore the form and its children. Use this feature to save a configuration that you are testing. Inactive forms are invisible to callers. When a node is inactive, it appears grayed out in the tree view.

Default Action check box

At any given "level" in the tree structure, one node can be marked as the default action. The operation defined by the [default node](#) is performed if the caller does not press a key within the timeout period specified by that menu. The icon for default forms has a green border in the tree structure. Any node below a menu or schedule can be marked as the [default action](#), by checking the form's default action check box.

Enable IVR Reporting

This option determines whether or not reporting data will be collected when control passes through this node. Several IVR Reports summarize this information. IVR Reporting is *disabled* by default. Enable it to capture the date, time and duration of time that the call remained in the node and its children. This option is hidden when Attendant is connected to a server that does not have reporting installed. For more information about this feature, see [IVR Reporting Option](#).

Add entry to the Interaction log

When this option is enabled, information about this node is appended to the call's Interaction Log when the call enters this node. This helps track the path that a call took through Attendant. The Interaction Log is maintained for reporting purposes. See [View the Interaction Log](#) for details.

Configure Speech Recognition... button

Select this button to configure words or phrases that can be associated with menu options. Callers can verbally indicate the options they want in the IVR instead of pressing a digit on the phone. You can enter multiple words and phrases for each menu item, just as callers may phrase the same request in different ways. For example, "transfer funds" or "funds transfer". See [Add Speech Recognition keywords or phrases to Inbound Call Operations](#).

Language to Use for prompts frame

The option in this frame control sets the current language to an available language.

Language to use for prompts list box

The language selected from this list becomes the current language used to play back prompts, presuming of course, that the caller presses a key to select this language selection node.

Action when Finished frame

These options set the processing that occurs after the operation completes successfully, when flow of control leaves this node. You can return control to the previous menu, disconnect the call, transfer to an operator profile, or jump to any node or action that has been defined for the current server. In most cases you will want to transfer control to another menu, as shown in the figure below.

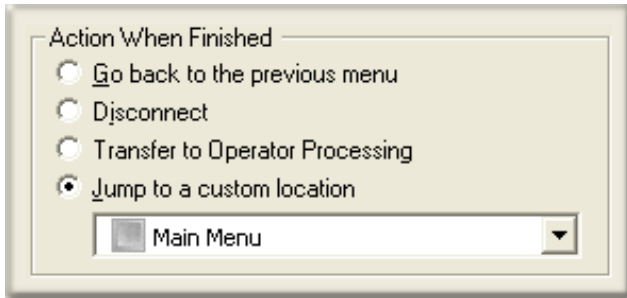

Go back to the previous menu radio button

This option returns control to the parent menu from which the message was played. This sets up a simple loop that "reruns" the parent menu from the top.

Disconnect radio button

This option disconnects the call.

Transfer to Operator Processing radio button

Transfers the call for evaluation by operator profiles defined for this server.

Jump to a custom location radio button

The *Jump to a custom location* radio button allows you to jump to any [profile](#), [schedule](#), [menu](#), or [operation](#) that is defined for the current server.

Related Topics

- [Manage Voice Prompts](#)

Logging

Logging appends information to the call's Interaction Log. This can be free-form text (up to 1024 characters), the value of a call attribute, the current date and time, data entered by the caller, or data retrieved using DB Query (CIC only). See also: [view the Interaction Log](#).

Agents can [View the Interaction Log](#) in Interaction Client to reveal the path that the call (or Email) took through Attendant, and other data items that help the agent to discern what the caller is looking for without having to ask the caller questions.

Node Characteristics frame

Options in this frame name the node, assign the digit used to select it, and establish whether or not it is active, used by default, logged, or tracked for reporting purposes.

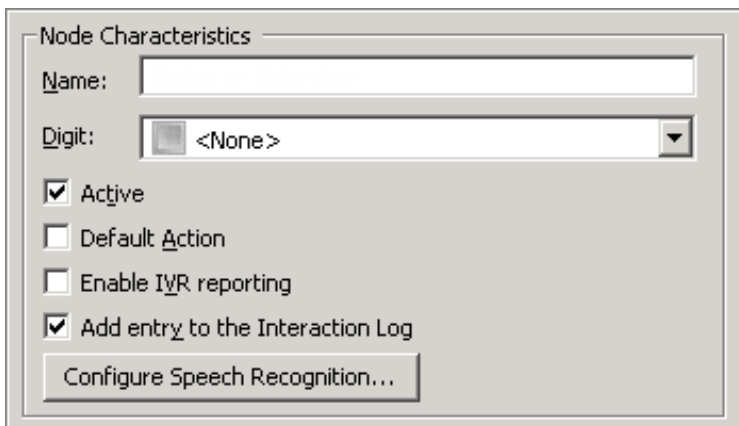

Name field

The label you enter here becomes the name of the node in the tree structure.

Digit list box

Use this list to select the key that callers press to enter a caller data entry operation. When you assign a digit, the list displays only available digits—those that are not already in use at this level of the tree. If no digit is assigned, callers cannot invoke the operation directly. It is possible to create menu options that are invoked by a routing process, rather than by a user selection. For details, see [invoke a menu operation automatically](#).

Active check box

By default, forms are "on", or "active", which means that Interaction Attendant will process them. If you uncheck a form's Active check box, the name of the node turns gray in the tree to indicate that the form is inactive. Interaction Attendant and its [handlers](#) will thereafter ignore the form and its children. Use this feature to save a configuration that you are testing. Inactive forms are invisible to callers. When a node is inactive, it appears grayed out in the tree view.

Default Action check box

At any given "level" in the tree structure, one node can be marked as the default action. The operation defined by the [default node](#) is performed if the caller does not press a key within the timeout period specified by that menu. The icon for default forms has a green border in the tree structure. Any node below a menu or schedule can be marked as the [default action](#), by checking the form's default action check box.

Enable IVR Reporting

This option determines whether or not reporting data will be collected when control passes through this node. Several IVR Reports summarize this information. IVR Reporting is *disabled* by default. Enable it to capture the date, time and duration of time that the call remained in the node and its children. This option is hidden when Attendant is connected to a server that does not have reporting installed. For more information about this feature, see [IVR Reporting Option](#).

Add entry to the Interaction Log

When this option is enabled, information about this node is appended to the call's Interaction Log when the call enters this node. This helps track the path that a call took through Attendant. The Interaction Log is maintained for reporting purposes. See [View the Interaction Log](#) for details.

Configure Speech Recognition... button

Select this button to configure words or phrases that can be associated with menu options. Callers can verbally indicate the options they want in the IVR instead of pressing a digit on the phone. You can enter multiple words and phrases for each menu item, just as callers may phrase the same request in different ways. For example, "transfer funds" or "funds transfer". See [Add Speech Recognition keywords or phrases to Inbound Call Operations](#).

Logging Information frame

The options in this section of the form control what is appended to the Interaction Log.

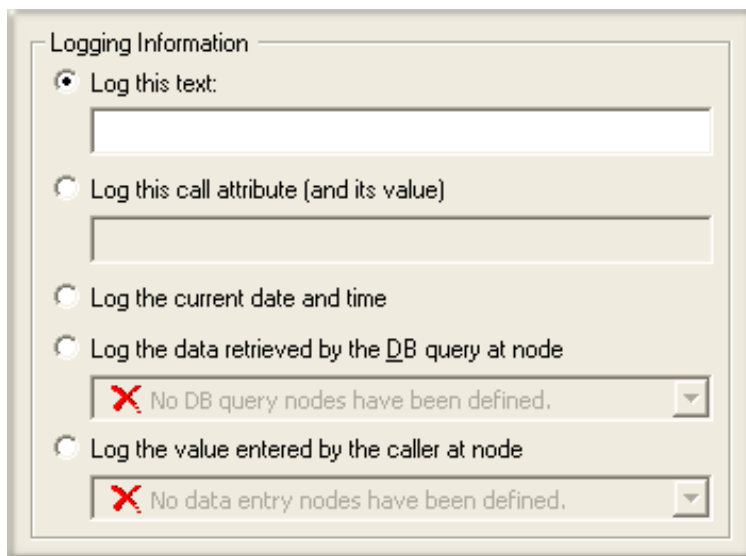

Log this text

When you select this option, you can enter up to 1024 characters of free-form text to the entry appended to the Interaction Log.

Log this call attribute (and its value)

Select this option to enter the name of a call attribute. At runtime, the value of the call attribute is appended to the Interaction Log as follows:

Attribute Name -> value of attribute

Log the current date and time

This option logs the current ISO timestamp to the Interaction Log. The format of the time stamp is:

YYYY-MM-DD HH:MM:SS

Log the data retrieved by the DB query at node

DB Query is available only in CIC and selected OEM editions of CIC. It queries a data source to retrieve a value. For example, a caller might select this operation from a menu to look up his account balance from your database. This option logs the result of the DB Query performed by a particular node to the call's Interaction Log. The log message is formatted as follows:

DB Query returned -> value

Log the value entered by the caller at node

This option logs data entered by the caller to the Interaction Log. You must specify which **Caller Data Entry** node was used. The log message is formatted as follows:

Caller input -> value

Action When Finished frame

These options set the processing that occurs after the operation completes successfully, when flow of control leaves this node. You can return control to the previous menu, disconnect the call, transfer to an operator profile, or jump to any node or action that has been defined for the current server.

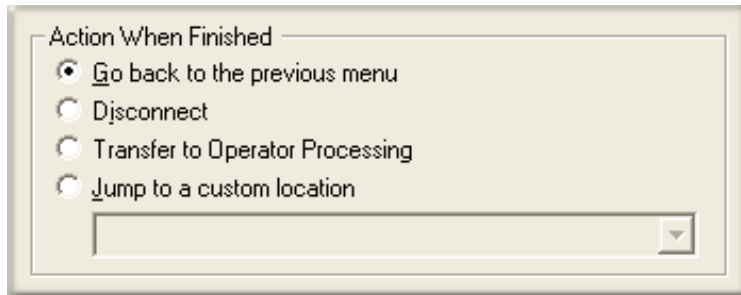

Go back to previous menu

This option returns control to the parent menu. This sets up a simple loop that "reruns" the menu from the top.

Disconnect

This option disconnects the call when the operation is completed successfully.

Transfer to Operator Processing

Transfers the call for evaluation by operator profiles defined for this server.

Jump to a custom location

This option allows you to jump to any [profile](#), [schedule](#), [menu](#), or [operation](#) that is defined for the current server.

Logical Transfer

A Logical Transfer transfers a call to another node, based on the result of a logical expression. This operation adds "branch-on-condition" capability to a menu, since it evaluates a logical expression to decide which node to transfer the call to.

A "logical expression" is a set of conditions that you specify. Expressions can be based on data entered by the caller, call attributes, the current time, data about a workgroup or data retrieved from a database.

These conditions determine where flow of control is passed when this operation executes. A logical expression always evaluates to True or False. For example, the statement, "Is today Saturday?" is a logical expression. If today is Saturday, the expression is True. Otherwise it is False.

Expressions are built using a simple wizard. An expression can be based on:

- data previously entered by the caller
- data about the current call
- the current time
- data about a particular workgroup
- data from a database

Note: The use of a Logical Transfer in an Expression Case can break the expected top-down execution order if you set the jump to location to another node in an Expression Case.

ACD Utilization is not taken into account when determining agent availability through Attendant. Specifically, the 'Logical Transfer'

step can be configured to do a check for the 'Number of available agents' within a provided workgroup. This check will return the number of agents who are 100% available. This means that any agent on an interaction will be considered unavailable regardless of how their ACD utilization is configured.

Node Characteristics frame

Options in this frame name the node, assign the digit used to select it, and establish whether or not it is active, used by default, logged, or tracked for reporting purposes.

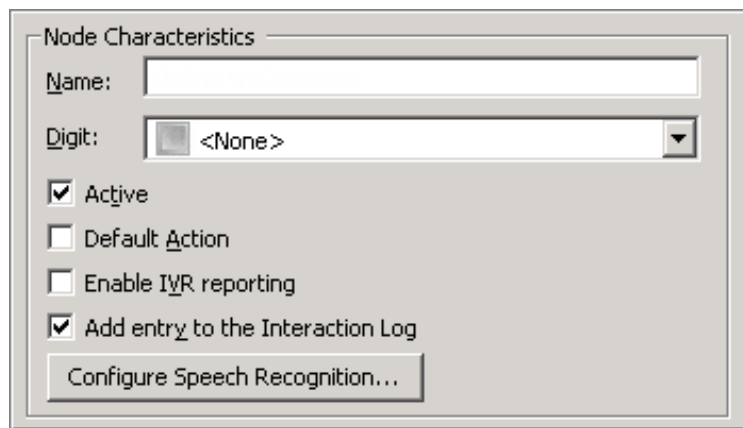
The image shows a dialog box titled "Node Characteristics". It contains several fields and checkboxes. At the top, there is a "Name:" label followed by a text input field. Below that is a "Digit:" label followed by a dropdown menu currently showing "<None>". There are four checkboxes: "Active" (checked), "Default Action" (unchecked), "Enable IVR reporting" (unchecked), and "Add entry to the Interaction Log" (checked). At the bottom of the dialog is a button labeled "Configure Speech Recognition...".

Name field

The label you enter here becomes the name of the node in the tree structure.

Digit list box

Use this list to select the key that callers press to enter a caller data entry operation. When you assign a digit, the list displays only available digits—those that are not already in use at this level of the tree. If no digit is assigned, callers cannot invoke the operation directly. It is possible to create menu options that are invoked by a routing process, rather than by a user selection. For details, see [invoke a menu operation automatically](#).

Active check box

By default, forms are "on", or "active", which means that Interaction Attendant will process them. If you uncheck a form's Active check box, the name of the node turns gray in the tree to indicate that the form is inactive. Interaction Attendant and its [handlers](#) will thereafter ignore the form and its children. Use this feature to save a configuration that you are testing. Inactive forms are invisible to callers. When a node is inactive, it appears grayed out in the tree view.

Default Action check box

At any given "level" in the tree structure, one node can be marked as the default action. The operation defined by the [default node](#) is performed if the caller does not press a key within the timeout period specified by that menu. The icon for default forms has a green border in the tree structure. Any node below a menu or schedule can be marked as the [default action](#), by checking the form's default action check box.

Enable IVR Reporting

This option determines whether or not reporting data will be collected when control passes through this node. Several IVR Reports summarize this information. IVR Reporting is *disabled* by default. Enable it to capture the date, time and duration of time that the call remained in the node and its children. This option is hidden when Attendant is connected to a server that does not have reporting installed. For more information about this feature, see [IVR Reporting Option](#).

Add entry to the Interaction Log

When this option is enabled, information about this node is appended to the call's Interaction Log when the call enters this node. This helps track the path that a call took through Attendant. The Interaction Log is maintained for reporting purposes. See [View the Interaction Log](#) for details.

Configure Speech Recognition... button

Select this button to configure words or phrases that can be associated with menu options. Callers can verbally indicate the options they want in the IVR instead of pressing a digit on the phone. You can enter multiple words and phrases for each menu item, just as callers may phrase the same request in different ways. For example, "transfer funds" or "funds transfer". See [Add Speech Recognition keywords or phrases to Inbound Call Operations](#).

Expression to Evaluate frame

This frame displays the expression that will be evaluated to return a Boolean (True or False) value. If no expression has been defined, it displays "No Expression Defined" and a pushbutton titled *Create Logical Expression* that opens the Expression Type wizard. If an expression has been defined, you can press the button titled "Modify Logical Expression" to edit the expression.

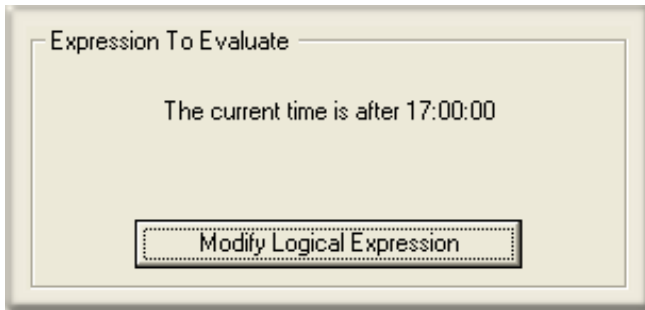

Create Logical Expression button

Opens the [Expression Type](#) wizard. Once an expression has been defined, the button caption changes to "Modify Logical Expression". If you press the button a second time, you are given the opportunity to change you selections.

Transfer Location frame

This frame sets the paths that are taken after the logical expression is evaluated. One path is taken when the expression is True. The other path is taken when the expression is False.

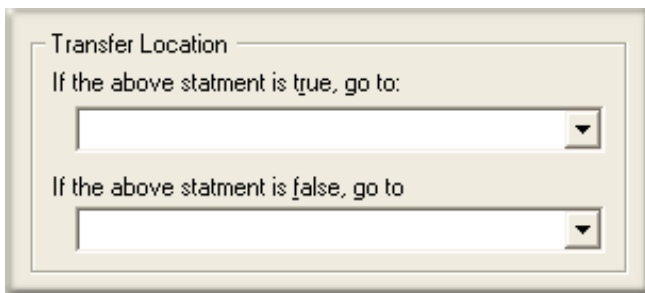

If the above statement is true, go to...

This list box allows you to select the path that is taken when the expression is True. You can select any [profile](#), [schedule](#), [menu](#), or [operation](#) that is defined for the current server.

If the above statement is false, go to...

This list box allows you to select the path that is taken when the expression is False. You can select any [profile](#), [schedule](#), [menu](#), or [operation](#) that is defined for the current server.

Related Topics

- [Expression Type Wizard](#)

Multi-Action Container

In general, Attendant forms execute without much caller intervention, in the order specified by the design. However, when the Attendant tree is sorted, the nodes that execute as a block are often separated, making it difficult to visually analyze a process. To avoid this problem, you can group nodes for a related process below a *Multi-Action* operation.

A Multi-Action node groups related steps of a process together, to create a call flow routine.

A Multi-Action node does not perform any actions itself. It is a container for other nodes that do perform actions. For instance, a common situation in Attendant is to prompt a user for his/her account number and then to look up a value in a database. This requires several steps (User Data Entry, DB Query, Menu, etc.) to implement.

In this example, steps can be grouped together to create a meta-node of sorts, by placing them below a Multi-Action node named "Get Account Data". This makes the call flow easier to inspect, since all nodes for the process remain together, regardless of sort order. Multi-Action nodes encapsulate other nodes into routines that are easier to understand and inspect in the tree view. Multi-Action nodes also provide an intermediate level of IVR reporting capability.

Since the children of a Multi-Action node are not sorted, you may arrange them in the order of execution, or in any other order, and they will stay in that visual order when the tree is sorted. However, the execution order of nodes is still controlled by the flow specified in each node's *Action When Finished*. The actions attached to a Multi-Action node can be sequentially. See *How to Run Actions Sequentially* below.

Multi-Action nodes work like folders to group other nodes together. They are implemented like menu nodes, but provide fewer configuration options. Each Multi-Action node is an organizational device only and as such it has few configurable options. Functionality is limited to optional call logging, IVR reporting, and prompt playback.

The behavior of child nodes in a Multi-Action node is slightly modified. Child nodes cannot be assigned a digit, since the Multi-Action node itself is assigned a digit. The Multi-Action node may be flagged as a default action for sibling nodes in the tree.

Important: You must check "Default Action" for one child of a Multi-Action node. Otherwise, the Multi-Action node will be marked in error, as the routine lacks an entry point.

Node Characteristics frame

Options in this frame name the node, assign the digit used to select it, and establish whether or not it is active, used by default, logged, or tracked for reporting purposes.

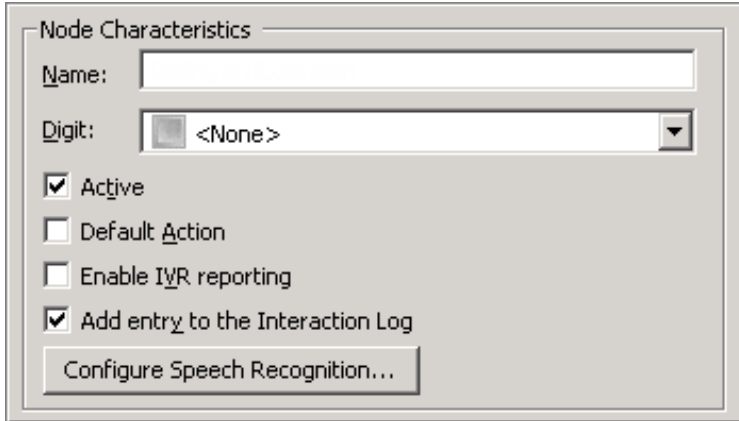

Name field

The label you enter here becomes the name of the node in the tree structure.

Digit list box

Use this list to select the key that callers press to enter a caller data entry operation. When you assign a digit, the list displays only available digits—those that are not already in use at this level of the tree. If no digit is assigned, callers cannot invoke the operation directly. It is possible to create menu options that are invoked by a routing process, rather than by a user selection. For details, see [invoke a menu operation automatically](#).

Active check box

By default, forms are "on", or "active", which means that Interaction Attendant will process them. If you uncheck a form's Active check box, the name of the node turns gray in the tree to indicate that the form is inactive. Interaction Attendant and its [handlers](#) will thereafter ignore the form and its children. Use this feature to save a configuration that you are testing. Inactive forms are invisible to callers. When a node is inactive, it appears grayed out in the tree view.

Default Action check box

At any given "level" in the tree structure, one node can be marked as the default action. The operation defined by the [default node](#) is performed if the caller does not press a key within the timeout period specified by that menu. The icon for default forms has a green border in the tree structure. Any node below a menu or schedule can be marked as the [default action](#), by checking the form's default action check box.

Enable IVR Reporting

This option determines whether or not reporting data will be collected when control passes through this node. Several IVR Reports summarize this information. IVR Reporting is *disabled* by default. Enable it to capture the date, time and duration of time that the call remained in the node and its children. This option is hidden when Attendant is connected to a server that does not have reporting installed. For more information about this feature, see [IVR Reporting Option](#).

Add entry to the Interaction Log

When this option is enabled, information about this node is appended to the call's Interaction Log when the call enters this node. This helps track the path that a call took through Attendant. The Interaction Log is maintained for reporting purposes. See [View the Interaction Log](#) for details.

Configure Speech Recognition... button

Select this button to configure words or phrases that can be associated with menu options. Callers can verbally indicate the options they want in the IVR instead of pressing a digit on the phone. You can enter multiple words and phrases for each menu item, just as callers may phrase the same request in different ways. For example, "transfer funds" or "funds transfer". See [Add Speech Recognition keywords or phrases to Inbound Call Operations](#).

Audio File frame

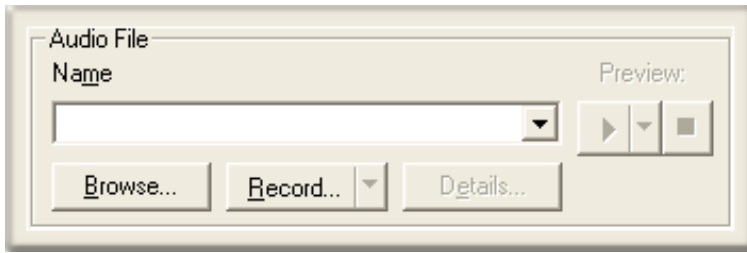

Controls in this frame set a prompt to play when control is passed to this node. If you do not select or record a prompt using the [embedded audio controls](#), no voice prompting will occur. See [manage voice prompts](#) for details.

How to Run Actions Sequentially

As mentioned above, the execution order of nodes is controlled by the flow specified in each node's *Action When Finished* frame. When an operation is attached to a Multi-Action node, an additional flow-of-control option appears in the form's *Action When Finished* frame. *Jump to the next node in this container* passes control to the node below the current node, in top-down order. This makes it easy to configure sequential operations, and bypasses the need to navigate the *Jump to a custom location* combo box. Attendant will pass control to the next node without requiring input from the user.

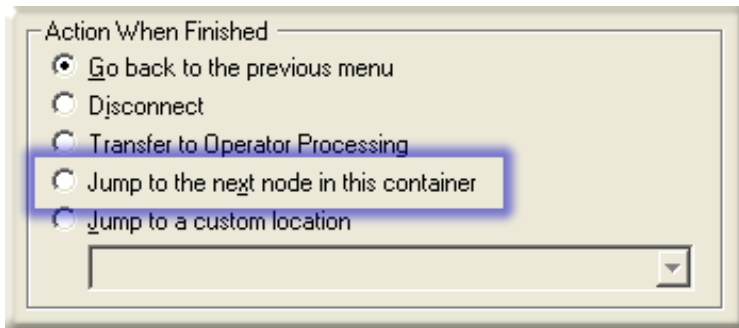

The basic rules are:

1. If "Jump to the next node" is selected and it is the last node in the container, Attendant considers the configuration to be invalid. It displays an error indicator next to the node in the tree view.
2. If "Jump to the next node" is selected and the node is copied or dragged out of the container, the Action When Finished selection reverts back to the default "Go back to the previous menu".

Other Tools

The *Other Tools* operation passes the call to a handler for processing. It invokes the handler that you select from a list of available handlers.

Node Characteristics frame

Options in this frame name the node, assign the digit used to select it, and establish whether or not it is active, used by default, logged, or tracked for reporting purposes.

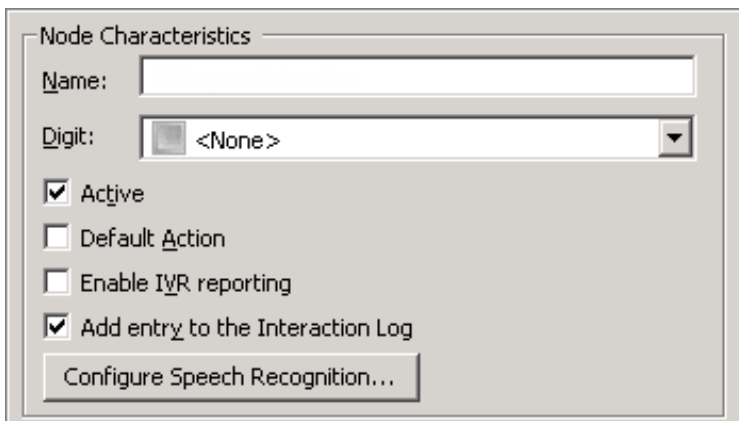

Name field

The label you enter here becomes the name of the node in the tree structure.

Digit list box

Use this list to select the key that callers press to enter a caller data entry operation. When you assign a digit, the list displays only available digits—those that are not already in use at this level of the tree. If no digit is assigned, callers cannot invoke the operation directly. It is possible to create menu options that are invoked by a routing process, rather than by a user selection. For details, see [invoke a menu operation automatically](#).

Active check box

By default, forms are "on", or "active", which means that Interaction Attendant will process them. If you uncheck a form's Active check box, the name of the node turns gray in the tree to indicate that the form is inactive. Interaction Attendant and its [handlers](#) will thereafter ignore the form and its children. Use this feature to save a configuration that you are testing. Inactive forms are invisible to callers. When a node is inactive, it appears grayed out in the tree view.

Default Action check box

At any given "level" in the tree structure, one node can be marked as the default action. The operation defined by the [default node](#) is performed if the caller does not press a key within the timeout period specified by that menu. The icon for default forms has a green border in the tree structure. Any node below a menu or schedule can be marked as the [default action](#), by checking the form's default action check box.

Enable IVR Reporting

This option determines whether or not reporting data will be collected when control passes through this node. Several IVR Reports summarize this information. IVR Reporting is *disabled* by default. Enable it to capture the date, time and duration of time that the call remained in the node and its children. This option is hidden when Attendant is connected to a server that does not have reporting installed. For more information about this feature, see [IVR Reporting Option](#).

Add entry to the Interaction Log

When this option is enabled, information about this node is appended to the call's Interaction Log when the call enters this node. This helps track the path that a call took through Attendant. The Interaction Log is maintained for reporting purposes. See [View the Interaction Log](#) for details.

Configure Speech Recognition... button

Select this button to configure words or phrases that can be associated with menu options. Callers can verbally indicate the options they want in the IVR instead of pressing a digit on the phone. You can enter multiple words and phrases for each menu item, just as callers may phrase the same request in different ways. For example, "transfer funds" or "funds transfer". See [Add Speech Recognition keywords or phrases to Inbound Call Operations](#).

Tool Selection

This section of the form identifies the handler that will be invoked.

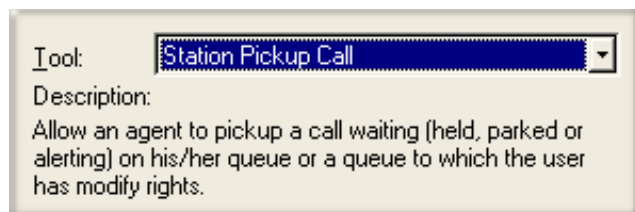

Tool:

Description:
Allow an agent to pickup a call waiting (held, parked or alerting) on his/her queue or a queue to which the user has modify rights.

Tool list box

This list box allows you to choose a special tool that has been created to extend Interaction Attendant. All interaction with these tools is performed over the telephone. You may not pass parameters (e.g. queue name, agent name, etc.) to the tool. These tools are available by default:

Agent Login/Logout

Allows an agent to login or logout from a station phone.

Append Attribute

Appends the value of source attr (passed in ATTR_SOURCE) onto the end of the target (name specified in ATTR_TARGET)

Copy Attribute

Copies attribute value (name passed in attribute ATTR_SOURCE) to another attribute (name specified in ATTR_TARGET).

Custom Group Pickup

Allows a station to pickup an alerting call on another station. Both stations must share membership in a Station Group with a name that includes the string "PickupGroup".

Fetch Result

Returns the result from the list of results ("|" delimited) in ATTR_RESULTS at position ATTR_LIST_INDEX. Result returned in ATTR_RESULT.

Great Plains Pad Number

Puts phone number in Microsoft Great Plains Phone Number format. Modifies ATTR_GP_PHONE.

Increment Index

Increments the value in ATTR_LIST_INDEX by 1.

Multi-Site

Allows an agent to pickup an inbound multi-site call. You must select this option if you are in a multi-site environment. It tells the system to check for DTMF tones that identify a Multi-Site (EMS) call. Inbound multi-site calls will be routed to the main menu if this option is not selected.

Parse Eic SIP Headers

In Interaction Administrator, one or more SIP headers may be defined during line configuration. This tool parses those SIP Headers into a set of name-pair attributes for use in Interaction Attendant or in custom sub-routines. Use this tool for SIP headers that contain name/value pair data. ATTR_NAME_PAIR_DELIMITER specifies the name value pair delimiter, and ATTR_NAME_PAIR_SEPARATOR specifies the separator between name and value. For each SIP header defined in Interaction Administrator, a call attribute will be created with the value from the SIP header on a new inbound call on the line. The call attribute name is configured with the prefix 'EicSIPHeader_' followed by the name of the SIP header. For example, a SIP header defined as "x-channel" will result in a call attribute titled "EicSIPHeader_x-channel".

Note: Administrators can define multiple SIP headers in Interaction Administrator. In these cases, a call attribute for each named header is created. Headers defined as Header1, Header2 and Header3 would result in attributes named EicSIPHeader_Header1, EicSIPHeader_Header2 and EicSIPHeader_Header3. The value of these attributes are semi-colon delimited name-pair values, separated by an "=" sign, for example, Name1=Value1;Name2=Value2;Name3=Value3.

Parse Name Pair Attributes

The functionality for this option has been deprecated.

Play TTS

Plays the value of the string contained in ATTR_TTS_INPUT. If an ATTR should be played in line, include it as follows: \$(ATTR_foo). The handler will remove the \$(.) and replace it with the string contained within the ATTR.

Station Pickup Call

Allows an agent to pickup a call that is waiting in a queue—the call may be held, parked, or alerting. The user must have "modify" rights to the queue that contains the call.

Additional tools may be added to this list. See [add additional tools to the tool list](#).

Description

When you select a tool, a brief synopsis of the tool is displayed. (See above.)

Action When Finished frame

These options set the processing that occurs after the operation completes successfully, when flow of control leaves this node. Some tools terminate the call. Others pass the call object back. The options in this frame select processing to perform if the tool passes the call back to Attendant when execution is complete.

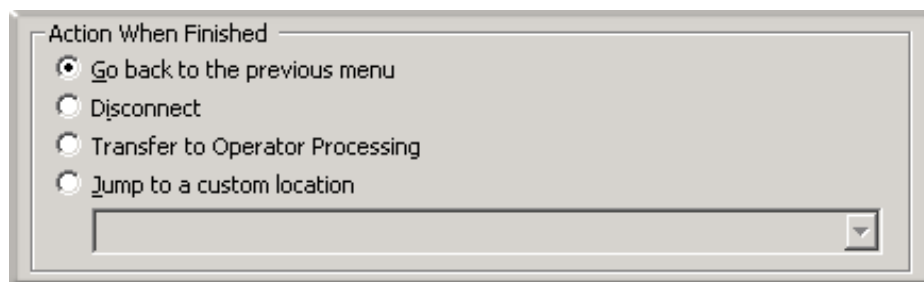

Go back to previous menu

This option returns control to the parent menu. This option sets up a simple loop that "reruns" the menu from the top.

Disconnect

This option disconnects the call when the data entry operation is completed successfully.

Transfer to Operator Processing

Transfers the interaction to the operator for processing by the Operator call flow configuration.

Jump to a custom location

This option allows you to jump to any profile, schedule, menu, or operation that is defined for the current server.

Add additional tools to the Tool list box

Additional tools can be added to the default selections listed in the Tool list. Attendant can read custom tool names and descriptions from a text file stored on the server. This allows a reseller or professional services associate to add new tools to the Other Tools form without requiring changes to Interaction Attendant.

To add tools, modify the existing OtherTools.IAT text file located in the \\servername\Resources share on the CIC Server. This file defines custom tools for use with Interaction Attendant's Other Tools node. This option is not licensed for customizations by partners or end customers. To add custom tool selections, the procedure is as follows:

1. From the \\servername\Resources share on the server, open the existing OtherTools.iat text file.
2. Enter the Tool Name, Handler name, and tool description, separated by vertical pipe (|) characters. This file should contain one line for each new tool, with each line formatted as follows:
 - <tool name>|<handler name>|<description>



- *Tool name* is the name of the tool as it should appear in the combo box of tools in the UI
 - *Handler name* is the name of the handler that should be executed when the tool is invoked. You do not need to add an .ihd extension after the name.
 - The *description* is the text that describes what the tool does. This text will appear below the combo box in the UI when the tool is selected.
3. Save the file. Thereafter, when a menu designer edits properties of an *Other Tools* node, he or she will be able to select the name of your custom tool from the list.

Play a Menu

A *menu* presents choices to the caller. *Menu choices* are nodes that have been assigned a digit.

A menu is a collection of one or more *menu entries* that process calls based on the keys a caller presses. Each menu entry is an operation form that executes when a digit is pressed. Menu nodes present a list of options to the caller.

Callers choose an entry by pressing a key on the telephone keypad. Based on the caller's choice, an auto attendant can offer a submenu, transfer a call to a queue, allow callers to search an employee directory, send or receive a fax, or perform many other actions.

To create a menu (or sub-menu), follow these steps:

1. Select the node in the tree that you want to attach the menu to. Menus are usually attached below [schedule](#) or [Multi-Action](#) nodes.
2. Press the *Menu* toolbar button (), or pull down the *Insert* menu, select *New Operation*, and finally *Play a Menu*.
3. Name the menu, and record an audio prompt that tells callers which keys they can press.
4. Set Repetition, Extension Dialing, and Fax options as needed.
5. Select the menu node in the tree (if it is not already selected). Then add operations to it to create menu choices. Name these entries, assign digits to them, and set flow of control options (action when finished).

Node Characteristics frame

Options in this frame name the node, assign the digit used to select it, and establish whether or not it is active, used by default, logged, or tracked for reporting purposes.

Name field

The label you enter here becomes the name of the node in the tree structure.

Digit list box

Use this list to select the key that callers press to enter a caller data entry operation. When you assign a digit, the list displays only available digits—those that are not already in use at this level of the tree. If no digit is assigned, callers cannot invoke the operation directly. It is possible to create menu options that are invoked by a routing process, rather than by a user selection. For details, see [invoke a menu operation automatically](#).

Active check box

By default, forms are "on", or "active", which means that Interaction Attendant will process them. If you uncheck a form's Active check box, the name of the node turns gray in the tree to indicate that the form is inactive. Interaction Attendant and its [handlers](#) will thereafter ignore the form and its children. Use this feature to save a configuration that you are testing. Inactive forms are invisible to callers. When a node is inactive, it appears grayed out in the tree view.

Default Action check box

At any given "level" in the tree structure, one node can be marked as the default action. The operation defined by the [default node](#) is performed if the caller does not press a key within the timeout period specified by that menu. The icon for default forms has a green border in the tree structure. Any node below a menu or schedule can be marked as the [default action](#), by checking the form's default action check box.

Enable IVR Reporting

This option determines whether or not reporting data will be collected when control passes through this node. Several IVR Reports summarize this information. IVR Reporting is *disabled* by default. Enable it to capture the date, time and duration of time that the call remained in the node and its children. This option is hidden when Attendant is connected to a server that does not have reporting installed. For more information about this feature, see [IVR Reporting Option](#).

Add entry to the Interaction Log

When this option is enabled, information about this node is appended to the call's Interaction Log when the call enters this node. This helps track the path that a call took through Attendant. The Interaction Log is maintained for reporting purposes. See [View the Interaction Log](#) for details.

Configure Speech Recognition... button

Select this button to configure words or phrases that can be associated with menu options. Callers can verbally indicate the options they want in the IVR instead of pressing a digit on the phone. You can enter multiple words and phrases for each menu item, just as callers may phrase the same request in different ways. For example, "transfer funds" or "funds transfer". See [Add Speech Recognition keywords or phrases to Inbound Call Operations](#).

Audio File frame

Use the [embedded audio controls](#) in this frame to select or record the prompt that plays when control is passed to this menu. Be sure to list all menu options in this message. Otherwise, callers will not know which keys to press, and will become confused. For procedural details, see [manage voice prompts](#).

Repetition frame

Controls in this frame set the number of times that the greeting will be played before control is passed to the schedule's error handler, or to this menu's [default node](#) if one exists, and the number of seconds to wait for caller input before repeating the audio prompt.

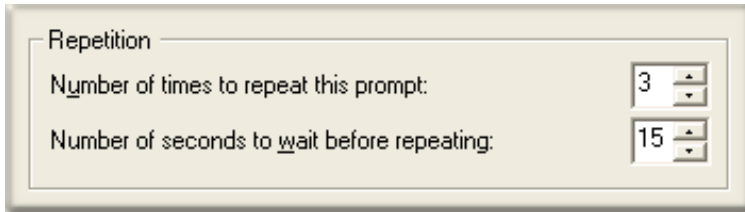

The image shows a control panel titled "Repetition". It contains two spin controls. The first is labeled "Number of times to repeat this prompt:" and has a value of 3. The second is labeled "Number of seconds to wait before repeating:" and has a value of 15.

Number of times to repeat this prompt spin control

This sets the number of times that the greeting will be played before control is passed to the schedule's error handler, or to the current menu's [default node](#) if one exists.

Number of seconds to wait before repeating spin control

This control sets the number of seconds that Interaction Attendant will wait before replaying the menu's audio prompt. The values set for *repeat* and *wait time* are processed, even if the audio name field is left blank, or its value is <None>. For example, if the repeat count is 2 and the delay time is 10, the caller will hear 20 seconds of dead air before the default action or error handler is invoked.

Extension Dialing frame

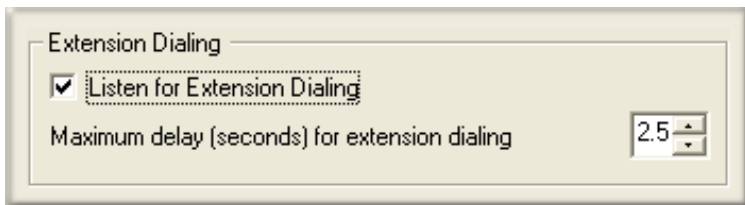

The image shows a control panel titled "Extension Dialing". It contains a checked checkbox labeled "Listen for Extension Dialing" and a spin control labeled "Maximum delay (seconds) for extension dialing" with a value of 2.5.

These optional settings are disabled by default. They allow you to enable auto-detection of extension dialing, which tells Attendant to process multiple incoming digits as extension numbers rather than as menu selections. This option appears on multiple forms. Please read [listen for extension dialing option](#) if you are unfamiliar with this feature.

Fax Listener button



Press this button to configure a menu to handle incoming faxes. It opens the [Fax Listener Options Dialog](#). Menus do not listen for Fax tones by default. When Fax Listening is enabled, incoming Faxes processed by the menu are routed to a mailbox.

Play Audio

This operation plays a wave audio (.wav) file for the caller. You can play an existing prompt file or record a new one using your station phone. You can assign node characteristics, such as the digit that users press to play back the message, the number of times that the message will be replayed if users do not make a menu selection, and the interval that Attendant will wait before replaying a message.

Node Characteristics frame

Options in this frame name the node, assign the digit used to select it, and establish whether or not it is active, used by default, logged, or tracked for reporting purposes.

Name field

The label you enter here becomes the name of the node in the tree structure.

Digit list box

Use this list to select the key that callers press to enter a caller data entry operation. When you assign a digit, the list displays only available digits—those that are not already in use at this level of the tree. If no digit is assigned, callers cannot invoke the operation directly. It is possible to create menu options that are invoked by a routing process, rather than by a user selection. For details, see [invoke a menu operation automatically](#).

Active check box

By default, forms are "on", or "active", which means that Interaction Attendant will process them. If you uncheck a form's Active check box, the name of the node turns gray in the tree to indicate that the form is inactive. Interaction Attendant and its [handlers](#) will thereafter ignore the form and its children. Use this feature to save a configuration that you are testing. Inactive forms are invisible to callers. When a node is inactive, it appears grayed out in the tree view.

Default Action check box

At any given "level" in the tree structure, one node can be marked as the default action. The operation defined by the [default node](#) is performed if the caller does not press a key within the timeout period specified by that menu. The icon for default forms has a green border in the tree structure. Any node below a menu or schedule can be marked as the [default action](#), by checking the form's default action check box.

Enable IVR Reporting

This option determines whether or not reporting data will be collected when control passes through this node. Several IVR Reports summarize this information. IVR Reporting is *disabled* by default. Enable it to capture the date, time and duration of time that the call remained in the node and its children. This option is hidden when Attendant is connected to a server that does not have reporting installed. For more information about this feature, see [IVR Reporting Option](#).

Add entry to the Interaction Log

When this option is enabled, information about this node is appended to the call's Interaction Log when the call enters this node. This helps track the path that a call took through Attendant. The Interaction Log is maintained for reporting purposes. See [View the Interaction Log](#) for details.

Configure Speech Recognition... button

Select this button to configure words or phrases that can be associated with menu options. Callers can verbally indicate the options they want in the IVR instead of pressing a digit on the phone. You can enter multiple words and phrases for each menu item, just as callers may phrase the same request in different ways. For example, "transfer funds" or "funds transfer". See [Add Speech Recognition keywords or phrases to Inbound Call Operations](#).

Audio frame

The options in this frame determine whether audio is played from an Attendant .wav file, audio sources defined in Interaction Administrator, or an audio file specified by a specific interaction attribute.

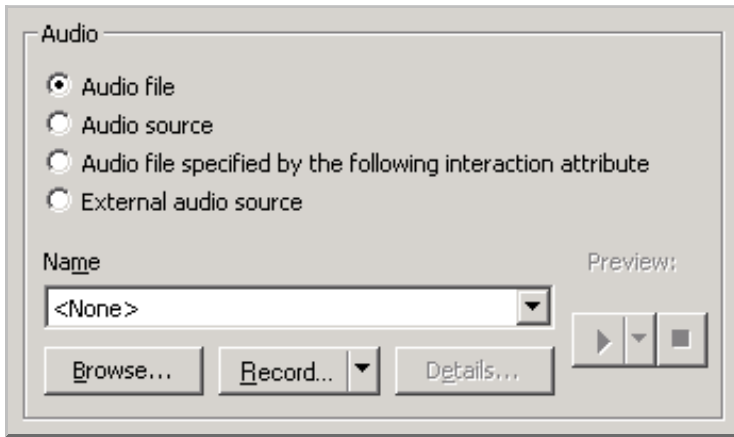

Audio Files radio button

If you click Audio Files, the embedded audio controls allow the selection of an Attendant .wav file, and additional options are presented in the Repetition frame. Repetition settings optionally replay the prompt to the caller. By default, the prompt plays once, and is not repeated.

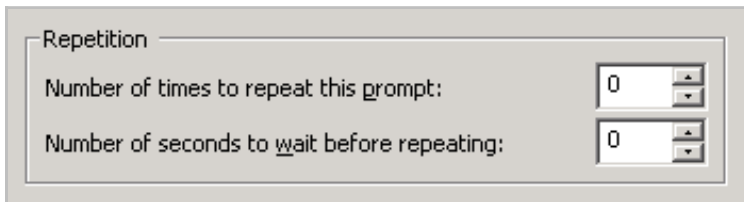

Number of times to repeat this prompt spin control

This control sets the number of times that the wave file will be played before control passes to the destination selected in the Action When Finished frame. By default this value is set to zero, so that the message plays once.

Number of seconds to wait before repeating spin control

This control sets the number of seconds that Interaction Attendant will wait before replaying the audio prompt. The default value is zero.

Tip—If the audio file name is left blank, or its value is <None>, control passes immediately to *Action When Finished* after the delay specified in the seconds spin control.

Audio Source radio button

If you click *Audio Sources*, the embedded audio controls allow the selection of any audio source defined in Interaction Administrator. Attendant will also prompt for a *Timeout* value that determines how long the audio source will play before control is passed to *Action When Finished* processing.

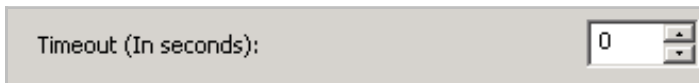

Audio file specified by the following interaction attribute radio button

If you click *Audio file specified by the following interaction attribute*, in the Name field enter the name of a custom attribute you define in the [Set Attribute](#) form, in the [Results Processing Dialog](#) of a [Database Query](#), or in a [Remote Data Query](#). The embedded audio controls use the audio file defined in this interaction attribute, but it must exist in the appropriate InteractionAttendantWaves folder. Attendant will also prompt for a *Timeout* value that determines how long the audio source will play before control is passed to *Action When Finished* processing.

External audio source

If you click *External Audio Source*, click the arrow at the end of the Name field dropdown list and select the appropriate source (for example, iPod or Pandora). Interaction Attendant will play audio from a file or audio source to a user in the IVR. These external audio sources must be defined and configured in Interaction Administrator before you can select them in the Play Audio node.

After you select the external audio source, in the *Timeout* area use the up and down arrows to select how many seconds to play the external audio source before control is passed to Action When Finished processing.

Action When Finished Frame

These options set the processing that occurs after the operation completes successfully, when flow of control leaves the node. You can return control to the previous menu, disconnect the call, transfer to an operator profile, or jump to any node or action that has been defined for the current server.

Go back radio button

The *Go back to the previous menu* radio button returns control to the parent menu from which the message was played. Suppose, for example, that you create a menu whose prompt is:

"Press 1 for information about product A."

"Press 2 for information about product B."

"Press 3 to hang up."

If you attached two Audio Playback operations to this menu, with *Go back to the previous menu* specified as the action to perform when finished, callers will hear the original prompt again when Audio Playback ends.

The Go back to the previous menu option

Sets up a simple loop that "reruns" the parent menu from the top.

Disconnect radio button

This option disconnects the call after replaying the wave file the number of times that is specified by the repeat value.

Transfer to Operator Processing

Transfers the call for evaluation by operator profiles defined for this server.

Jump to radio button

This option allows you to jump to any [profile](#), [schedule](#), [menu](#), or [operation](#) that is defined for the current server. Flow of control will pass to this destination once the wave file has been played the number of time specified by the repeat value.

Play Info

The *Play Info* action plays wave audio files like the Play Audio action, but adds the ability to play audio containing information retrieved from call attributes. You can specify an ordered sequence of audio bits to be played. Each audio bit can consist of an audio .wav file followed by audio generated from a specified call attribute.

Any call attribute can be used, including reserved call attributes. For information about reserved call attributes, see *Interaction Attributes Technical Reference* in the PureConnect Documentation Library.

The attributes most commonly used with this action are attributes set elsewhere in the profile, (e.g. through the use of Set Attribute actions, or attributes set as the result of retrieving data from a DB query.

Node Characteristics frame

Options in this frame name the node, assign the digit used to select it, and establish whether or not it is active, used by default, logged, or tracked for reporting purposes.

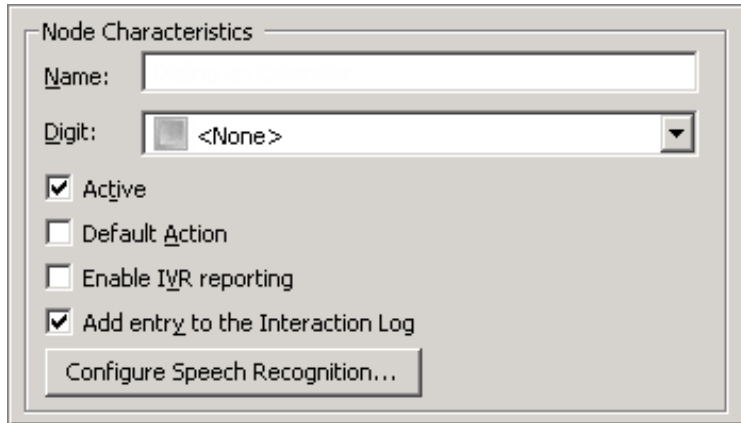

The screenshot shows a dialog box titled "Node Characteristics". It has a "Name:" text input field. Below it is a "Digit:" dropdown menu currently showing "<None>". There are four checkboxes: "Active" (checked), "Default Action" (unchecked), "Enable IVR reporting" (unchecked), and "Add entry to the Interaction Log" (checked). At the bottom is a button labeled "Configure Speech Recognition...".

Name field

The label you enter here becomes the name of the node in the tree structure.

Digit list box

Use this list to select the key that callers press to enter a caller data entry operation. When you assign a digit, the list displays only available digits—those that are not already in use at this level of the tree. If no digit is assigned, callers cannot invoke the operation directly. It is possible to create menu options that are invoked by a routing process, rather than by a user selection. For details, see [invoke a menu operation automatically](#).

Active check box

By default, forms are "on", or "active", which means that Interaction Attendant will process them. If you uncheck a form's Active check box, the name of the node turns gray in the tree to indicate that the form is inactive. Interaction Attendant and its [handlers](#) will thereafter ignore the form and its children. Use this feature to save a configuration that you are testing. Inactive forms are invisible to callers. When a node is inactive, it appears grayed out in the tree view.

Default Action check box

At any given "level" in the tree structure, one node can be marked as the default action. The operation defined by the [default node](#) is performed if the caller does not press a key within the timeout period specified by that menu. The icon for default forms has a green border in the tree structure. Any node below a menu or schedule can be marked as the [default action](#), by checking the form's default action check box.

Enable IVR Reporting

This option determines whether or not reporting data will be collected when control passes through this node. Several IVR Reports summarize this information. IVR Reporting is *disabled* by default. Enable it to capture the date, time and duration of time that the call remained in the node and its children. This option is hidden when Attendant is connected to a server that does not have reporting installed. For more information about this feature, see [IVR Reporting Option](#).

Add entry to the Interaction Log

When this option is enabled, information about this node is appended to the call's Interaction Log when the call enters this

node. This helps track the path that a call took through Attendant. The Interaction Log is maintained for reporting purposes. See [View the Interaction Log](#) for details.

Configure Speech Recognition... button

Select this button to configure words or phrases that can be associated with menu options. Callers can verbally indicate the options they want in the IVR instead of pressing a digit on the phone. You can enter multiple words and phrases for each menu item, just as callers may phrase the same request in different ways. For example, "transfer funds" or "funds transfer". See [Add Speech Recognition keywords or phrases to Inbound Call Operations](#).

Audio Sequence frame

The screenshot shows the 'Audio Sequence' frame with a table containing the following data:

Audio File	Attribute	Data Format
ICMainGreeting.wav	DateTimeAttr	Date Time
ICThankYouHoldi...	<Not Used>	Text
<Not Used>	FirstNameAttr	First Name
<Not Used>	LastNameAttr	Text
PromptWorkgrou...	CustomAudioAttribute	Audio File

Buttons on the right side of the frame include 'Add', 'Remove', 'Edit', and two arrow buttons (up and down) for reordering.

Use options in the Audio Sequence frame to select and order audio files to play. The list view that contains the audio sequence to be played contains controls for moving audio entries up or down allowing for easily arranging the sequence for previously configured audio bits.

To configure options in this frame, follow this procedure:

1. Click Add. The *Play Info Sequence* dialog appears.

The screenshot shows the 'Play Info Sequence Entry' dialog box with the following fields and controls:

- Audio File: ICMainGreeting.wav
- Attribute: DateTimeAttr
- Attribute Format: Date Time
- Custom Format: (empty)
- Table with columns: Attribute Value, Audio File
- Buttons: Add, Remove, Edit
- Buttons: OK, Cancel

2. Select an audio file from the *Audio File* drop list, or select *<Not Used>*.
3. Type the name of an attribute in the *Attribute* field. Audio will be generated from the specified attribute. If this field is left blank, the system will assign *<Not Used>* to indicate that an attribute should not be played.

4. If an attribute is specified, select the data format of the attribute using the *Attribute Format* drop list. The call attribute formats are:

Audio File A .wav file that exists in the appropriate InteractionAttendantWaves folder.

Boolean True or False.

Custom The Custom data format sets up a switch comparison that evaluates attribute values and .wav audio files to be played. If an attribute value is something other than all of the defined values, no audio is played.

If you set the format to *Custom*, you are prompted to provide attribute value/audio file pairs associated with that entry as well.

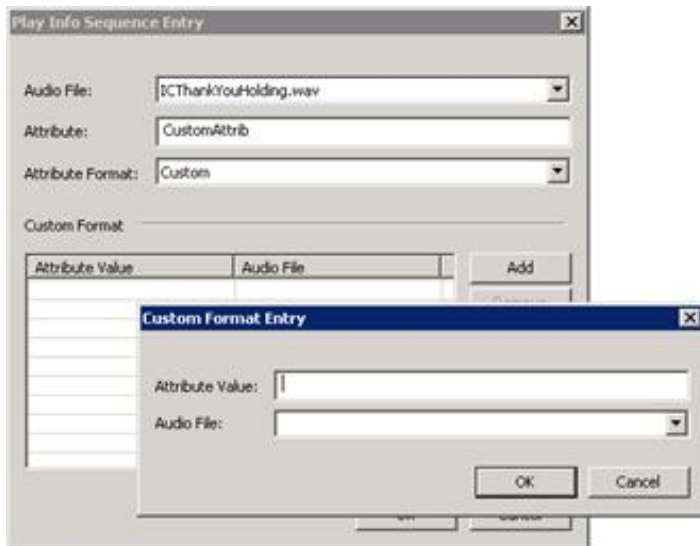

Date Year, month, and day in the form: YYYY-MM-DD.

Date Time The date and time in one of the following forms:

If you set the Attribute Format to Text:	If you set the Attribute Format to Date:
YYYY-MM-DD HH:MM:SS.SSS	yyyymmddhhmmssZ
YYYYMMDDHHMMSS[TZ]	yyyymmddhhmmss
YYYY-MM-DD	yyyymmddhhmmZ
	yyyymmddhhmm
	yyyymmddZ
	yyyymmdd

First Name Play Info allows playback of call attribute values as either a first or last name data type. The 1000 most common U.S. male and female first names and the 1000 most common U.S. last names are supplied as wave files in a folder library. The playback will play from this library of names if the recorded name exists and will use text-to-speech (TTS) if not. Each language can have its own name library. All name libraries are extensible by adding additional recorded names to the recording folders. The default libraries are:

1000MostCommonNamesMale.txt: U.S. 1000 most common male first names.

1000MostCommonNamesFemale.txt: U.S. 1000 most common female first names.

1000MostCommonNamesSurname.txt: U.S. 1000 most common last names.

Last Name See First Name.

Monetary A monetary value. There is a limitation on the monetary data type of 2,147,483,647, due to the data type used.

Numeric A number.

Phone Number Telephone Number.

Text Text converted to speech.

Time Plays the Time portion of a Date Time attribute.

Unique Digits A series of one or more digits.

5. Click *Ok* to dismiss the *Play Info Sequence* dialog. A new entry will appear in the Audio Sequence list.
6. Click *Add* to define additional entries as needed.
7. Optionally use the up and down arrow buttons to change the order of entries. Entries are evaluated from top to bottom.

Audio Sequence Play Mode frame

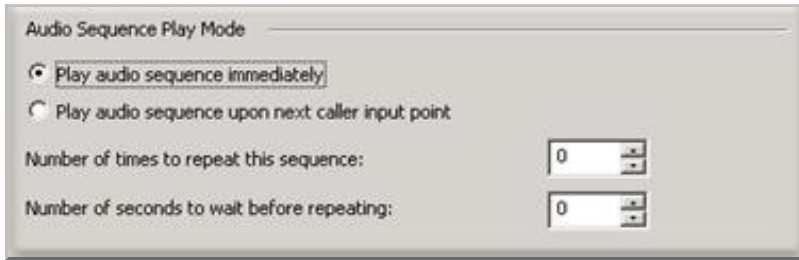

Two different play modes are available:

Immediate mode

The audio sequence plays immediately when the action is reached in the IVR tree. In Immediate mode, you can configuration of number of times to repeat sequence and the amount of time to wait in between.

Play at the next caller data input point

Queues, but does not play the audio sequence when the Play Info node is reached in the IVR tree. Audio is played when a subsequent caller data input point (Caller data entry node or a menu node) is reached in the IVR tree.

Action When Finished frame

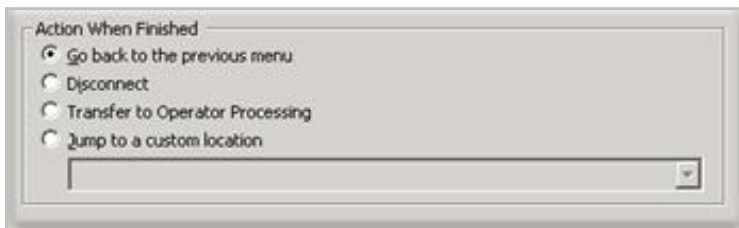

Go back to the previous menu radio button

The *Go back to the previous menu* option returns control to the parent menu from which the message was played.

The Go back to the previous menu option

Sets up a simple loop that "reruns" the parent menu from the top.

Disconnect radio button

This option disconnects the call after replaying the wave file the number of times that is specified by the repeat value.

Transfer to Operator Processing

Transfers the call for evaluation by operator profiles defined for this server.

Jump to radio button

This option allows you to jump to any [profile](#), [schedule](#), [menu](#), or [operation](#) that is defined for the current server. Flow of control will pass to this destination once the wave file has been played the number of time specified by the repeat value.



Receive Fax

This operation receives an incoming Fax, and routes it to a mailbox. The caller is prompted to begin transmission of the document. Afterwards, the node listens for FAX tones. Once the Fax has been received, it is routed to the default mailbox (configured in Interaction Administrator), or to a specific agent or workgroup mailbox.

Node Characteristics frame

Options in this frame name the node, assign the digit used to select it, and establish whether or not it is active, used by default, logged, or tracked for reporting purposes.

Name field

The label you enter here becomes the name of the node in the tree structure.

Digit list box

Use this list to select the key that callers press to enter a caller data entry operation. When you assign a digit, the list displays only available digits—those that are not already in use at this level of the tree. If no digit is assigned, callers cannot invoke the operation directly. It is possible to create menu options that are invoked by a routing process, rather than by a user selection. For details, see [invoke a menu operation automatically](#).

Active check box

By default, forms are "on", or "active", which means that Interaction Attendant will process them. If you uncheck a form's Active check box, the name of the node turns gray in the tree to indicate that the form is inactive. Interaction Attendant and its [handlers](#) will thereafter ignore the form and its children. Use this feature to save a configuration that you are testing. Inactive forms are invisible to callers. When a node is inactive, it appears grayed out in the tree view.

Default Action check box

At any given "level" in the tree structure, one node can be marked as the default action. The operation defined by the [default node](#) is performed if the caller does not press a key within the timeout period specified by that menu. The icon for default forms has a green border in the tree structure. Any node below a menu or schedule can be marked as the [default action](#), by checking the form's default action check box.

Enable IVR Reporting

This option determines whether or not reporting data will be collected when control passes through this node. Several IVR Reports summarize this information. IVR Reporting is *disabled* by default. Enable it to capture the date, time and duration of time that the call remained in the node and its children. This option is hidden when Attendant is connected to a server that does not have reporting installed. For more information about this feature, see [IVR Reporting Option](#).

Add entry to the Interaction Log

When this option is enabled, information about this node is appended to the call's Interaction Log when the call enters this node. This helps track the path that a call took through Attendant. The Interaction Log is maintained for reporting purposes. See [View the Interaction Log](#) for details.

Configure Speech Recognition... button

Select this button to configure words or phrases that can be associated with menu options. Callers can verbally indicate the options they want in the IVR instead of pressing a digit on the phone. You can enter multiple words and phrases for each menu item, just as callers may phrase the same request in different ways. For example, "transfer funds" or "funds transfer". See [Add Speech Recognition keywords or phrases to Inbound Call Operations](#).

Send the fax to frame

These options determine whether the FAX is received and sent to the default mailbox for fax recipients (as configured in Interaction Administrator), to a specific user, or to the mailbox shared by a workgroup.

Default Mailbox button

Routes the Fax to the CIC default mailbox configured in Interaction Administrator. For more information, ask your CIC administrator for information about the default fax recipient, or consult Interaction Administrator help.

User's mailbox combo

Routes the Fax to the mailbox of an Interaction Client user.

Workgroup mailbox combo

Routes the Fax to a workgroup mailbox. If the system cannot route the Fax to the workgroup's mailbox, the Fax is routed to the default user's mailbox instead.

Remote Access

The Remote Access operation allows a caller to retrieve voice mail from a remote location, to change status, or manage recorded prompts. Once this menu entry is accessed, the caller must enter his or her extension and CIC password, and then press the pound (#) key.

This is the default behavior for voice mail retrieval. Your system administrator may have changed default voice mail retrieval settings. Contact your system administrator for more information on Voicemail retrieval functionality and passwords.

Node Characteristics frame

Options in this frame name the node, assign the digit used to select it, and establish whether or not it is active, used by default, logged, or tracked for reporting purposes.

Name field

The label you enter here becomes the name of the node in the tree structure.

Digit list box

Use this list to select the key that callers press to enter a caller data entry operation. When you assign a digit, the list displays only available digits—those that are not already in use at this level of the tree. If no digit is assigned, callers cannot invoke the operation directly. It is possible to create menu options that are invoked by a routing process, rather than by a user selection. For details, see [invoke a menu operation automatically](#).

Active check box

By default, forms are "on", or "active", which means that Interaction Attendant will process them. If you uncheck a form's Active check box, the name of the node turns gray in the tree to indicate that the form is inactive. Interaction Attendant and its [handlers](#)

will thereafter ignore the form and its children. Use this feature to save a configuration that you are testing. Inactive forms are invisible to callers. When a node is inactive, it appears grayed out in the tree view.

Default Action check box

At any given "level" in the tree structure, one node can be marked as the default action. The operation defined by the [default node](#) is performed if the caller does not press a key within the timeout period specified by that menu. The icon for default forms has a green border in the tree structure. Any node below a menu or schedule can be marked as the [default action](#), by checking the form's default action check box.

Enable IVR Reporting

This option determines whether or not reporting data will be collected when control passes through this node. Several IVR Reports summarize this information. IVR Reporting is *disabled* by default. Enable it to capture the date, time and duration of time that the call remained in the node and its children. This option is hidden when Attendant is connected to a server that does not have reporting installed. For more information about this feature, see [IVR Reporting Option](#).

Add entry to the Interaction Log

When this option is enabled, information about this node is appended to the call's Interaction Log when the call enters this node. This helps track the path that a call took through Attendant. The Interaction Log is maintained for reporting purposes. See [View the Interaction Log](#) for details.

Configure Speech Recognition... button

Select this button to configure words or phrases that can be associated with menu options. Callers can verbally indicate the options they want in the IVR instead of pressing a digit on the phone. You can enter multiple words and phrases for each menu item, just as callers may phrase the same request in different ways. For example, "transfer funds" or "funds transfer". See [Add Speech Recognition keywords or phrases to Inbound Call Operations](#).

Security frame

A screenshot of a software interface titled "Security". It contains a label "Access Code:" followed by a rectangular text input field.

Access Code field

This field allows you to specify additional digits that a caller must press to access remote Voicemail. For example, you may not want callers accidentally accessing your Voicemail retrieval system. Adding additional digits that a caller must press can make it more difficult for someone to accidentally or maliciously access voice mail retrieval.

Action When Finished frame

These options set the processing that occurs after the operation completes successfully, when flow of control leaves the node. You can return control to the previous menu, disconnect the call, transfer to an operator profile, or jump to any node or action that has been defined for the current server.

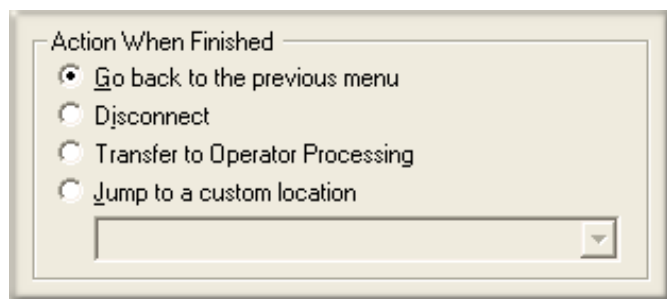
A screenshot of a software interface titled "Action When Finished". It contains four radio button options: "Go back to the previous menu" (which is selected), "Disconnect", "Transfer to Operator Processing", and "Jump to a custom location". Below these options is a text input field with a dropdown arrow on the right side.

Go back to previous menu

This option sets up a simple loop that "reruns" the menu from the top.

Disconnect

This option disconnects the call when the data entry operation is completed successfully.

Transfer to Operator Processing

Transfers the call for evaluation by operator profiles defined for this server.

Jump to a custom location

This option allows you to jump to any [profile](#), [schedule](#), [menu](#), or [operation](#) that is defined for the current server.

The Remote Data Query action calls a web service to retrieve data returned in call attributes. This action works like a Database Query, but calls a SOAP web service to retrieve data. Also, it allows for multiple data items to be retrieved instead of a single item. The data items retrieved are returned in call attributes as specified in the configuration.

The example configuration in this topic retrieves the current temperature for a hard-code ZIP (46278), and puts the value returned into a call attribute that could be played back to the caller using a [Play Info](#) node. The table below lists configuration

Example Web Service	http://ws.cdyne.com/weatherws/weather.asmx
Example SOAP Action	http://ws.cdyne.com/WeatherWS/GetCityWeatherByZIP
Example XML	<pre><?xml version="1.0" encoding="utf-8"?> <soap:Envelope xmlns:soap="http://schemas.xmlsoap.org/soap/envelope/" xmlns:xsi="http://www.w3.org/2001/XMLSchema-instance" xmlns:s="http://www.w3.org/2001/XMLSchema" xmlns:enc="http://schemas.xmlsoap.org/soap/encoding"> <soap:Body> <tns:GetCityWeatherByZIP xmlns:tns="http://ws.cdyne.com/WeatherWS/"> <tns:ZIP>46278</tns:ZIP> </tns:GetCityWeatherByZIP> </soap:Body> </soap:Envelope></pre>

Node Characteristics frame

Options in this frame name the node, assign the digit used to select it, and establish whether or not it is active, used by default, logged, or tracked for reporting purposes.

Name field

The label you enter here becomes the name of the node in the tree structure.

Digit list box

Use this list to select the key that callers press to enter a caller data entry operation. When you assign a digit, the list displays only available digits—those that are not already in use at this level of the tree. If no digit is assigned, callers cannot invoke the operation directly. It is possible to create menu options that are invoked by a routing process, rather than by a user selection. For details, see [invoke a menu operation automatically](#).

Active check box

By default, forms are "on", or "active", which means that Interaction Attendant will process them. If you uncheck a form's Active check box, the name of the node turns gray in the tree to indicate that the form is inactive. Interaction Attendant and its [handlers](#) will thereafter ignore the form and its children. Use this feature to save a configuration that you are testing. Inactive forms are invisible to callers. When a node is inactive, it appears grayed out in the tree view.

Default Action check box

At any given "level" in the tree structure, one node can be marked as the default action. The operation defined by the [default node](#) is performed if the caller does not press a key within the timeout period specified by that menu. The icon for default forms has a green border in the tree structure. Any node below a menu or schedule can be marked as the [default action](#), by checking the form's default action check box.

Enable IVR Reporting

This option determines whether or not reporting data will be collected when control passes through this node. Several IVR Reports summarize this information. IVR Reporting is *disabled* by default. Enable it to capture the date, time and duration of time that the call remained in the node and its children. This option is hidden when Attendant is connected to a server that does not have reporting installed. For more information about this feature, see [IVR Reporting Option](#).

Add entry to the Interaction Log

When this option is enabled, information about this node is appended to the call's Interaction Log when the call enters this node. This helps track the path that a call took through Attendant. The Interaction Log is maintained for reporting purposes. See [View the Interaction Log](#) for details.

Configure Speech Recognition... button

Select this button to configure words or phrases that can be associated with menu options. Callers can verbally indicate the options they want in the IVR instead of pressing a digit on the phone. You can enter multiple words and phrases for each menu item, just as callers may phrase the same request in different ways. For example, "transfer funds" or "funds transfer". See [Add Speech Recognition keywords or phrases to Inbound Call Operations](#).

Data Query Input frame

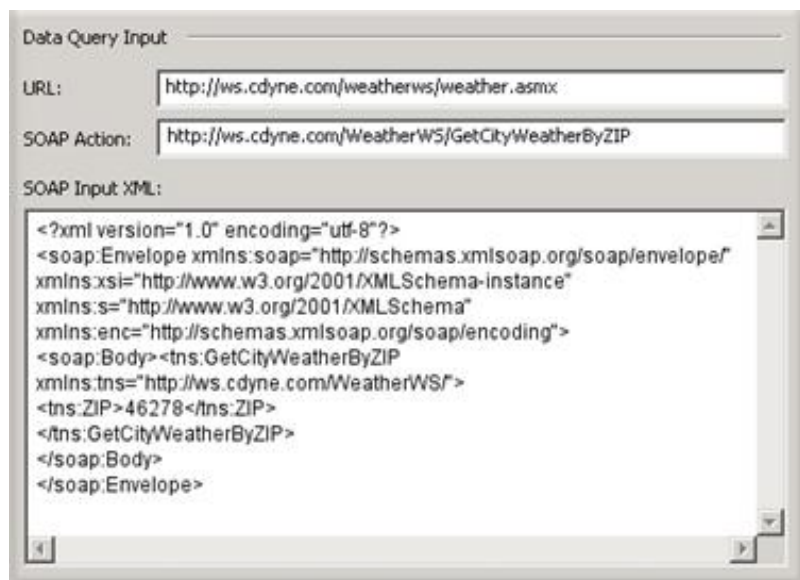

The screenshot shows a web form titled "Data Query Input". It contains three main sections: "URL:" with the value "http://ws.cdyne.com/weatherws/weather.asmx"; "SOAP Action:" with the value "http://ws.cdyne.com/WeatherWS/GetCityWeatherByZIP"; and "SOAP Input XML:" with a text area containing the following XML code:

```
<?xml version="1.0" encoding="utf-8"?>
<soap:Envelope xmlns:soap="http://schemas.xmlsoap.org/soap/envelope/"
xmlns:xsi="http://www.w3.org/2001/XMLSchema-instance"
xmlns:s="http://www.w3.org/2001/XMLSchema"
xmlns:enc="http://schemas.xmlsoap.org/soap/encoding">
<soap:Body><tns:GetCityWeatherByZIP
xmlns:tns="http://ws.cdyne.com/WeatherWS/">
<tns:ZIP>46278</tns:ZIP>
</tns:GetCityWeatherByZIP>
</soap:Body>
</soap:Envelope>
```

URL

The URL of a SOAP web service.

SOAP Action

The SOAP Action to execute. A SOAP action indicates to the service what action it should perform.

SOAP Input XML

An XML message that contains:

- a *Header* element that contains header information
- a *SOAP Envelope* element that identifies the XML document as a SOAP message
- a *Body* element that contains call and response information. In the example above, the zip code (46278) is passed in the ZIP element. To reference a call attribute in the SOAP Input XML field, the Body element can contain references to call attributes in the form: $\$(AttributeName)$
- For example: `<tns:ZIP>$(ATTR_Zip)</tns:ZIP>`

Data Query Output frame

Data Query Output

XML Name	Attribute Name
Temperature	Temperature

Timeout (Zero means use the web service timeout): seconds

This section configures attributes that will receive the result values from the web service. To complete this section, click *Add*. You will be prompted to identify the name of the XML service result element that contains the data, and for the name of a call attribute to hold the data returned.

Remote Data Query Output

XML Name:

Attribute Name:

You can define multiple attributes to receive additional data items returned by the service.

Security Use enhanced SOAP request tool (with SSL and user authentication support) check box

Check this option to specify that the handler should use the enhanced SOAP request tool that has support for SSL and user authentication. Checking this box enables use of SSL, and also enables the *Enhanced SOAP Request Tool Configuration* button, so that you can open the dialog that manages configuration parameters for SSL.

Enhanced SOAP Request Tool Configuration button

Opens SSL configuration parameters for editing in the *Enhanced SOAP Tool Configuration* dialog.

Enhanced SOAP Tool Configuration

User Authentication

Username:

Password:

Client Certificate

Certificate Subject's Common Name (CN):

Ignore unknown SSL certificate authority
 Ignore wrong SSL certificate usage
 Ignore SSL certificate name mismatch
 Ignore invalid SSL certificate date

Timeouts (In seconds)

Request:

Connect:

DNS Resolve:

Username/Password

Username and password for sites that require HTTP authentication.

Certificate Subject's Common Name

The common name on the security certificate. The certificate common name usually matches the site name exactly. For example, if the site is "www.domain.com" you would enter a common name of www.domain.com, unless you elect to use a wild card such as *.domain.com that matches all sub-domains of the domain.com.

Ignore unknown SSL certificate authority

When checked, continue processing if the SSL certificate authority is unknown.

Ignore wrong SSL certificate usage

When checked, continue processing if the SSL certificate is malformed (e.g. no subject name).

Ignore SSL certificate name mismatch

When checked, continue processing if the hostname of the visited host and the server certificate do not match.

Ignore invalid SSL certificate date

When checked, continue processing if the SSL certificate has expired or its date is invalid.

Request Timeout

Sets the maximum time in seconds to wait for request to be sent and response to be completely received.

Connect Timeout

Sets the maximum time in seconds to wait for connection to be established.

DNS Resolve Timeout

Sets the maximum time in seconds to wait for name resolution to complete.

Timeout and Error Handling options



You can set a custom timeout interval that takes the failure path if the service does not respond within a specific number of seconds. If you leave this value at its default value (0), the web service's timeout will be used.

Error handling is also configurable. You can respond to errors by setting up a custom jump, or use the default error handling at the schedule level. The default error handler for the schedule is used by default, but you can change the error handler to jump to a custom location by clicking the *Error Handling* button.

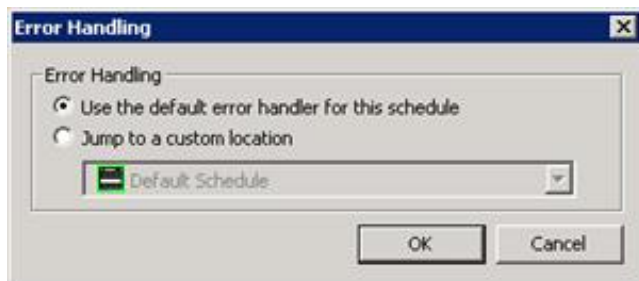

Action When Finished frame

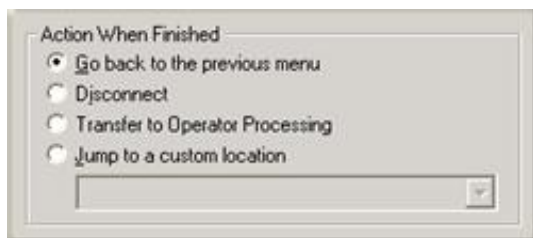

That action when finished path is taken upon a successful call to the web service.

Go back to previous menu

This option sets up a simple loop that "reruns" the menu from the top.

Disconnect

This option disconnects the call when the operation is completed successfully.

Transfer to Operator Processing

Transfers the call for evaluation by operator profiles defined for this server.

Jump to a custom location

This option allows you to jump to any [profile](#), [schedule](#), [menu](#), or [operation](#) that is defined for the current server.

Run Subroutine

This operation passes an interaction (a call or Email object) to a handler. This node is sometimes called "Subroutine Initiator", since it invokes a custom handler from within Attendant. Handlers are hidden programs that contain and execute the functionality configured in Interaction Attendant. Specifically, *Run Subroutine* passes a call identifier and subroutine name to the CustomSubroutineInitiatorRouter handler.

Run Subroutine is not available in all editions of CIC.

The interaction is passed to the subroutine specified in this node and also in the [CustomSubroutineInitiatorRouter handler](#). The processing that the subroutine performs occurs is up to the handler author.

For example, if you have a handler that looks up account balances, you could send a call to that handler allowing the caller to enter a user ID and password. The handler would then play the account balance and return back to the Interaction Attendant menu it was called from.

Important

Before using *Run Subroutine* in Interaction Attendant, you must use Interaction Designer to modify the CustomSubroutineInitiatorRouter handler. For procedural details, see [modify CustomSubroutineInitiator.ihd](#).

This help topic doesn't explain everything that you need to know about handlers. For exhaustive information, refer to Interaction Designer's help system.

Node Characteristics frame

Options in this frame name the node, assign the digit used to select it, and establish whether or not it is active, used by default, logged, or tracked for reporting purposes.

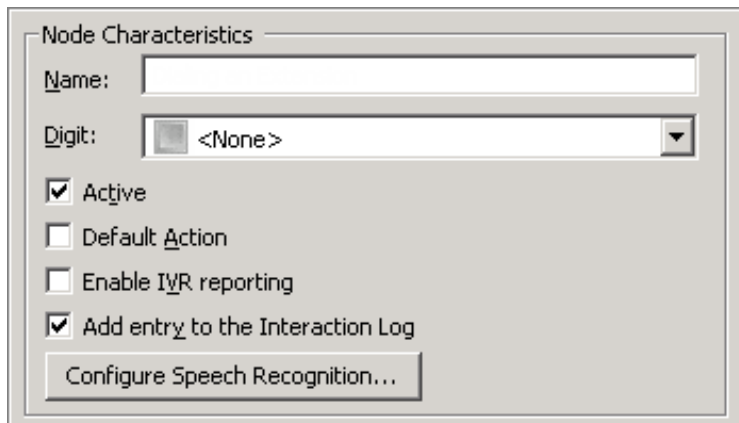

The screenshot shows a dialog box titled "Node Characteristics". It has the following elements:

- Name:** A text input field.
- Digit:** A dropdown menu currently showing "<None>".
- Active:** A checked checkbox.
- Default Action:** An unchecked checkbox.
- Enable IVR reporting:** An unchecked checkbox.
- Add entry to the Interaction Log:** A checked checkbox.
- Configure Speech Recognition...:** A button at the bottom.

Name field

The label you enter here becomes the name of the node in the tree structure.

Digit list box

Use this list to select the key that callers press to enter a caller data entry operation. When you assign a digit, the list displays only available digits—those that are not already in use at this level of the tree. If no digit is assigned, callers cannot invoke the operation directly. It is possible to create menu options that are invoked by a routing process, rather than by a user selection. For details, see [invoke a menu operation automatically](#).

Active check box

By default, forms are "on", or "active", which means that Interaction Attendant will process them. If you uncheck a form's Active

check box, the name of the node turns gray in the tree to indicate that the form is inactive. Interaction Attendant and its [handlers](#) will thereafter ignore the form and its children. Use this feature to save a configuration that you are testing. Inactive forms are invisible to callers. When a node is inactive, it appears grayed out in the tree view.

Default Action check box

At any given "level" in the tree structure, one node can be marked as the default action. The operation defined by the [default node](#) is performed if the caller does not press a key within the timeout period specified by that menu. The icon for default forms has a green border in the tree structure. Any node below a menu or schedule can be marked as the [default action](#), by checking the form's default action check box.

Enable IVR Reporting

This option determines whether or not reporting data will be collected when control passes through this node. Several IVR Reports summarize this information. IVR Reporting is *disabled* by default. Enable it to capture the date, time and duration of time that the call remained in the node and its children. This option is hidden when Attendant is connected to a server that does not have reporting installed. For more information about this feature, see [IVR Reporting Option](#).

Add entry to the Interaction Log

When this option is enabled, information about this node is appended to the call's Interaction Log when the call enters this node. This helps track the path that a call took through Attendant. The Interaction Log is maintained for reporting purposes. See [View the Interaction Log](#) for details.

Configure Speech Recognition... button

Select this button to configure words or phrases that can be associated with menu options. Callers can verbally indicate the options they want in the IVR instead of pressing a digit on the phone. You can enter multiple words and phrases for each menu item, just as callers may phrase the same request in different ways. For example, "transfer funds" or "funds transfer". See [Add Speech Recognition keywords or phrases to Inbound Call Operations](#).

Subroutine

A rectangular input field with a light beige background and a thin border. On the left side, the text "Subroutine:" is displayed in a dark font. To the right of the text is a large, empty rectangular box for entering the subroutine name.

Subroutine Name

Type the name of the subroutine that you want to run. This subroutine name must also be defined in the Select step of the CustomSubroutineInitiatorRouter handler. See [modify CustomSubroutineInitiator.ihd](#).

To pass parameters to the Handler

Sometimes it is desirable to pass data from Attendant to a handler. There are two ways to do this.

- You can use the [Set Attribute](#) node to assign a value to a custom attribute, and configure the node to jump to any profile, schedule, menu, or operation that is defined for the current server. If the interaction is processed by the handler later, the handler can retrieve the value stored in the attribute.
- You can also invoke a handler directly from Attendant and pass the value. To do this, use the *Run Subroutine* node to specify a subroutine to run. To pass a value, append a colon followed by the parameter value to the subroutine name. For example, if the name of the subroutine is Voicemail and you want to pass the extension number of the end user, you would enter "Voicemail:133" in the subroutine field.

Action When Finished frame

These options set the processing that occurs after the operation completes successfully, when flow of control leaves the node. You can return control to the previous menu, disconnect the call, transfer to an operator profile, or jump to any node or action that has been defined for the current server.

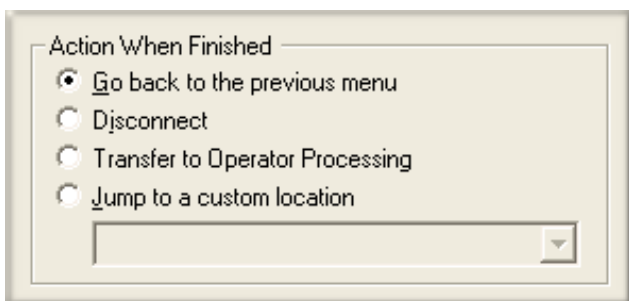
A rectangular frame with a light beige background and a thin border. At the top left, the text "Action When Finished" is displayed. Below this text are four radio button options: "Go back to the previous menu" (selected), "Disconnect", "Transfer to Operator Processing", and "Jump to a custom location". At the bottom of the frame is a dropdown menu with a small arrow pointing down on its right side.

Select the flow of control that occurs when the subroutine runs successfully and no errors are encountered. However, these options are not evaluated unless your custom subroutine returns False in a Boolean named p_bTransferred.

If your custom subroutine transfers the call to another thread (does not return the call to Attendant), the subroutine should assign False to a Boolean return value named p_bTransferred. If the call is returned to Attendant, it should set p_bTransferred to True.

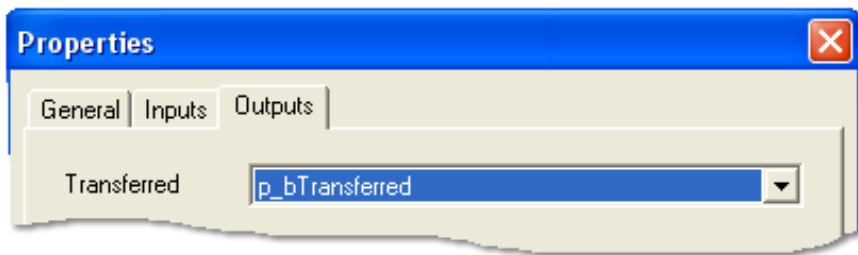

The p_bTransferred return value is passed back to the Run Subroutine node when the custom subroutine finishes. It indicates whether or not Attendant should ignore or process the flow-of-control selections you make in *Actions When Finished* frame. If the return value is True, this tells Attendant that the call was transferred by the subroutine, and no actions need to be performed on the call, since Attendant no longer has it.

When the custom subroutine is created in Interaction Designer, it should assign a Boolean value to p_bTransferred to indicate whether the call is transferred (True) or returned to Interaction Attendant for further processing (False).

If the return value is True, flow-of-control settings in the Subroutine Initiator form are ignored. If the return value is False, the action specified in the form is processed as follows:

Go back to previous menu

The *Go back to the previous menu* radio button returns control to the parent menu. This option sets up a simple loop that "reruns" the menu from the top.

Disconnect

This option disconnects the call when the data entry operation is completed successfully.

Transfer to Operator Processing

Transfers the call for evaluation by operator profiles defined for this server.

Jump to a custom location

This option allows you to jump to any [profile](#), [schedule](#), [menu](#), or [operation](#) that is defined for the current server.

Related Topics

- [Modify CustomSubroutineInitiator.ihd](#)
- [Other Tools](#)

Voicebot

The Voicebot allows integration with bots like Google Dialogflow via Genesys Cloud. After an Attendant flow routes to the bot, the bot takes over and captures the caller intent and fills the output slots.

For example, the bot matches the caller spoken responses with the intent schedule an appointment and a filled slot.

When the bot completes, the call routes back into the Attendant flow, the intent and slot values are captured into call attributes, and Attendant's existing capabilities then allow the flow to operate based on the filled intent and slot data.

Run Voicebot

This operation allows integration with bots like Google Dialogflow via Genesys Cloud. After an Attendant flow routes to the bot, the bot takes over and captures the caller intent and filled slots. For example, the bot matches the caller's spoken responses with the intent *Schedule an Appointment* and a filled slot of 10:00am for the time.

When the bot completes, the call routes back into the Attendant flow, then the intent and slot values are captured in the call attributes and Attendant's existing flow. Then the Voicebot allows the flow to operate based on the filled intent and slot data.

Add Run Voicebot to Attendant

To add Run Voicebot operation, follow these steps:

1. Select the node in the tree that you want to add the Run Voicebot operation.
2. Press the **Menu** toolbar button (), or pull down the **Insert** menu, select **New Operation**, and finally select **Run Voicebot**.

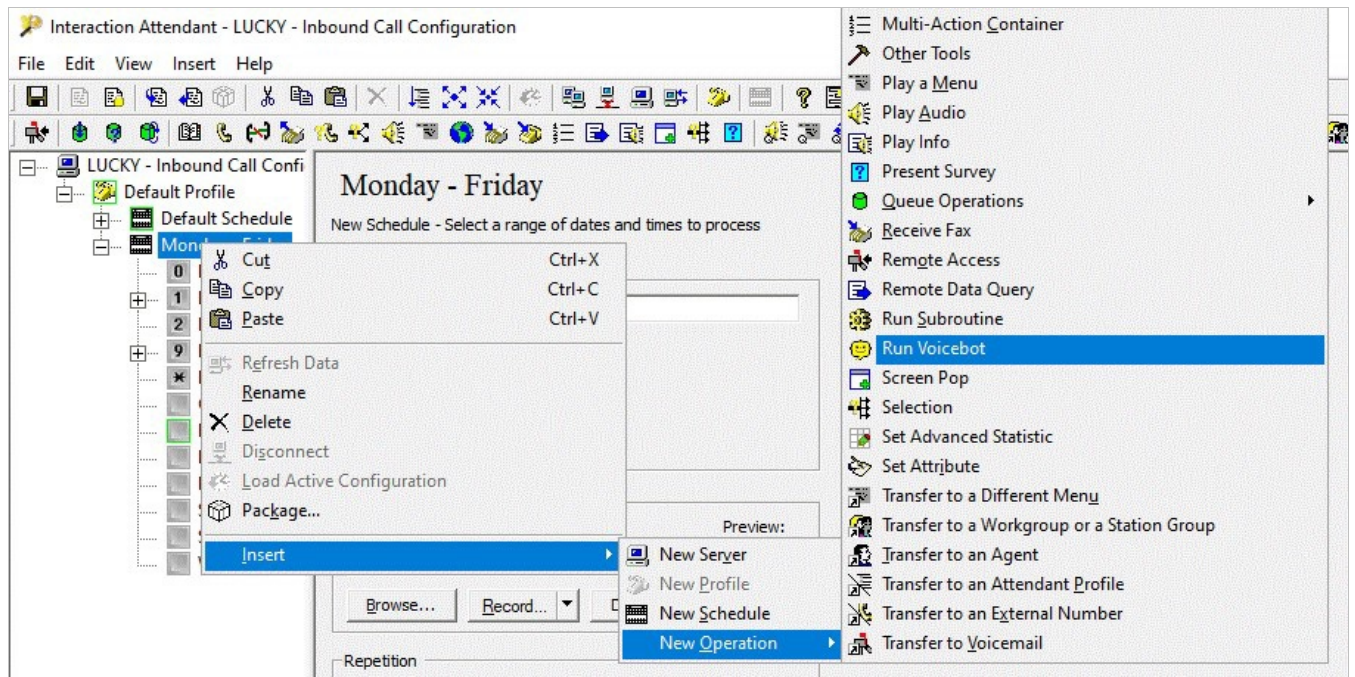

3. To the selected menu node tree, Voicebot is added.

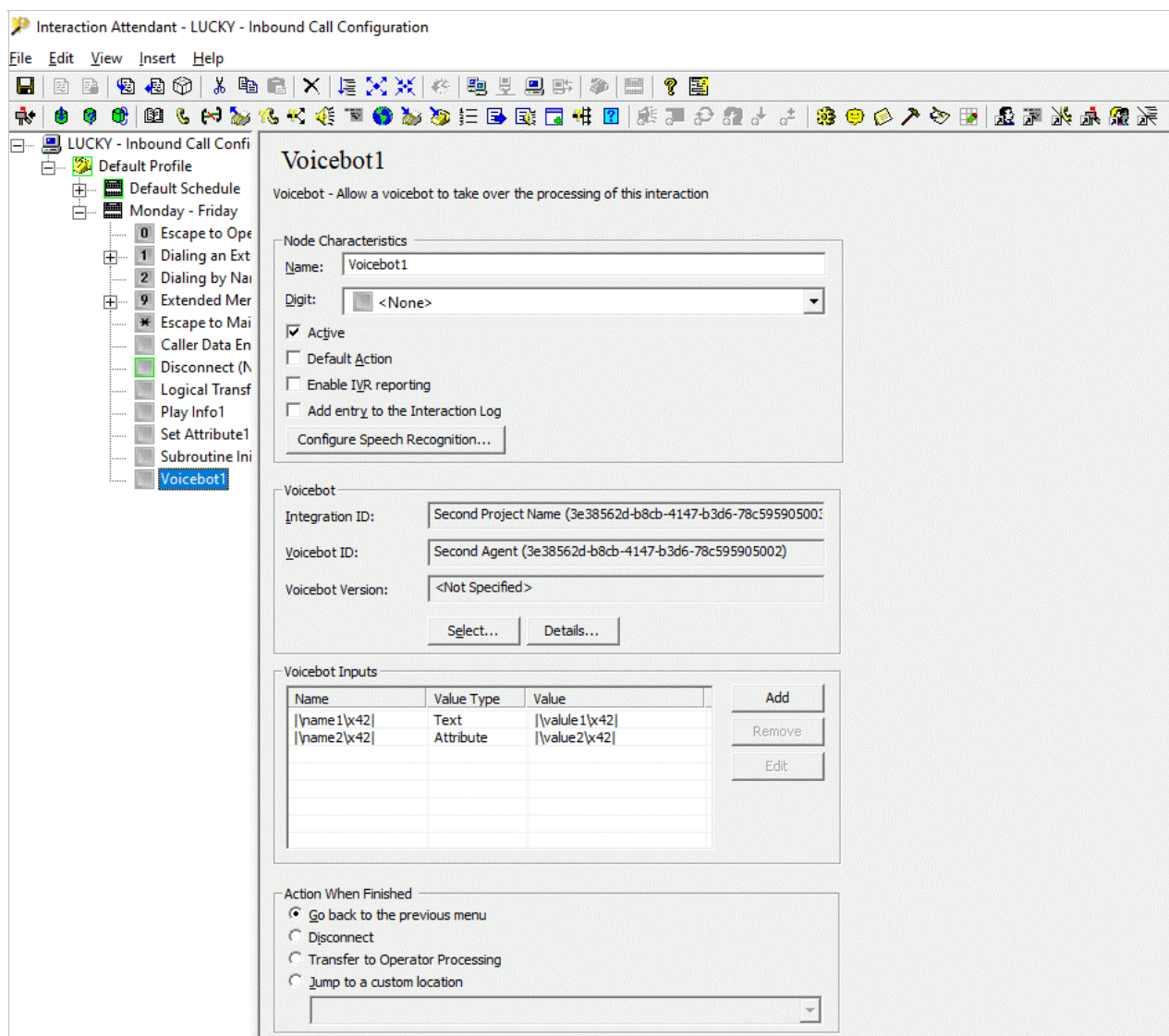

Voicebot

A new Interaction Attendant operation Voicebot is introduced, which allows integration with the bots like Google Dialogflow via Genesys Cloud.

After an Attendant flow routes to the bot, the bot takes over and captures the caller intent and fills the output **slots**. For example, the bot matches the caller spoken responses with the intent **schedule an appointment** and a filled slot of 10:00 am for the time.

When the bot completes the interaction, the call continues in the Interaction Attendant flow, the intent, and slot values are captured into call attributes, which Interaction Attendant's existing capabilities can be used to control it is based on the filled intent and slot data.

Node Characteristics frame

Options in this frame name the node, assign the digit used to select it, and establish whether it is active or not, used by default, logged, or tracked for reporting purposes.

Name field

The label you enter here becomes the name of the node in the tree structure.

Digit list box

Use this list to select the key that callers press to enter a caller data entry operation. When you assign a digit, the list displays only available digits that are not already in use at this level of the tree. If no digit is assigned, callers cannot invoke the operation directly. It is possible to create menu options that are invoked by a routing process, rather than by a user selection.

Active check box

By default, the forms are on, or active, which means that the Interaction Attendant processes them. If you uncheck a form's Active check box, the name of the node turns gray in the tree to indicate that the form is inactive. Interaction Attendant and its handlers will ignore the form and its children. Use this feature to save a configuration that you are testing. Inactive forms are invisible to callers. When a node is inactive, it appears gray in the tree view.

Default Action check box

At any given "level" in the tree structure, one node can be marked as the default action. The operation defined by the default node is performed if the caller does not press a key within the timeout period specified by that menu. The icon for default forms has a green border in the tree structure. Any node below a menu or schedule can be marked as the default action, by checking the form's default action check box.

Enable IVR Reporting

This option determines whether reporting data is collected or not when control passes through this node. Several IVR Reports summarize this information. IVR Reporting is disabled by default. Enable it to capture the date, time, and duration of time that the call remained in the node and its children. This option is hidden when the Attendant is connected to a server that does not have reporting installed.

Add entry to the Interaction Log

When this option is enabled, information about this node is appended to the call's Interaction Log when the call enters this node. This helps track the path that a call took through the Attendant. The Interaction Log is maintained for reporting purposes.

Configure Speech Recognition... button

Select this button to configure words or phrases that can be associated with menu options. Callers can verbally indicate the options that they want in the IVR instead of pressing a digit on the phone. You can enter multiple words and phrases for each menu item, just as callers may phrase the same request in different ways. For example, transfer funds or funds transfer.

Voicebot input values

When the bot completes the interaction, the call continues in the Interaction Attendant flow, the intent, and slot values are captured into call attributes, which Interaction Attendant's existing capabilities can be used to control it is based on the filled intent and slot data.

Node Characteristics frame

Options in this frame name the node, assign the digit used to select it, and establish whether it is active or not, used by default, logged, or tracked for reporting purposes.

Name field

The label you enter here becomes the name of the node in the tree structure.

Digit list box

Use this list to select the key that callers press to enter a caller data entry operation. When you assign a digit, the list displays only available digits that are not already in use at this level of the tree. If no digit is assigned, callers cannot invoke the operation directly. It is possible to create menu options that are invoked by a routing process, rather than by a user selection.

Active check box

By default, the forms are on, or active, which means that the Interaction Attendant processes them. If you uncheck a form's Active check box, the name of the node turns gray in the tree to indicate that the form is inactive. Interaction Attendant and its handlers ignore the form and its children. Use this feature to save a configuration that you are testing. Inactive forms are invisible to callers.

Default Action check box

At any given "level" in the tree structure, one node can be selected as the default action. The operation defined by the default node is performed if the caller does not press a key within the timeout period specified by that menu. The icon for default forms has a green border in the tree structure. Any node below a menu or schedule can be selected as the default action, by checking the form's default action check box.

Enable IVR Reporting

This option determines whether reporting data is collected or not when control passes through this node. Several IVR Reports summarize this information. IVR Reporting is inactive by default. Enable it to capture the date, time, and duration of time that the call remained in the node and its children. This option is hidden when the Attendant is connected to a server that does not have reporting installed.

Add entry to the Interaction Log

When this option is enabled, information about this node is appended to the call's Interaction Log when the call enters this node.

Configure Speech Recognition... button

Select this button to configure words or phrases that can be associated with menu options. Callers can verbally indicate the options that they want in the IVR instead of pressing a digit on the phone. You can enter multiple words and phrases for each menu item, just as callers may phrase the same request in different ways. For example, transfer funds or funds transfer.

Voicebot selection

From Voicebot selection dialog page Agent can select the Project Name and voicebot version.

Voicebot input values

Voicebot Input Value Allows specification of a list of input name/value pairs which send to the Voicebot at runtime. The value can be either a literal Text string or the name of a call attribute.

For example, the value is typed as **Attribute** the specified call attribute is queried at runtime and passed to the bot. This provides a powerful mechanism for passing data such as the calling number to the bot.

Voicebot frame Integration ID

Allows to view the project name.

Voicebot ID

Allows to view the agent details.

VoiceBot Version

Provides the Voicebot version details if any specific version is selected, if not shows **Not Specified**.

Voicebot Selection dialog box

Integration ID:	Second Project Name (3e38562d-b8cb-4147-b3d6-78c59590500)
Voicebot ID:	Second Agent (3e38562d-b8cb-4147-b3d6-78c595905002)
Voicebot Version:	<Not Specified>

Select... Details...

Voicebot Selection dialog box

Voicebot ID

Allows to select the agent details.

Voicebot Version check box

Allows to select the **Use specific voicebot version** check box and to select the required version from the list.

Voicebot Selection

Voicebot ID:

Voicebot Version: Use specific voicebot version

Voicebot Details:

```
VoicebotType: "Google Dialogflow"
AgentId: "3e38562d-b8cb-4147-b3d6-78c595905002"
AgentName: "Second Agent"
AgentDescription: "Second Dialogflow Agent"
ProjectId: "3e38562d-b8cb-4147-b3d6-78c595905003"
ProjectName: "Second Project Name"
SelfUri: ""
Languages:
  0: "en-US"
Environments:
  0: "?????"
Intents / Parameters:
  0: "Third Intent Name"
  { "parameter": "Third boring parameter value" }
  { "parameter": "Third boring parameter value" }
  1: "Fourth Intent Name"
  { "parameter": "Fourth boring parameter value" }
  { "parameter": "Fourth boring parameter value" }
```

OK Cancel

Voicebot Details

Allows to view the Voicebot information like Voicebot Type, Agent ID, Agent Name, Agent description, Project ID, Project Name, Self Uri, Languages, Environments, and Intents/ Parameters.

Voicebot inputs frame

Voicebot Inputs allows specification for a list of input name/value pairs which are sent to the Voicebot at runtime. The value can be either a literal Text string or the name of a call attribute.

For example, the value is typed as Attribute, then the specified call attribute is queried at runtime and passed to the bot. This provides a mechanism for passing the data such as the calling number to the bot.

Add

Allows to add Voicebot input values.

Voicebot Input Value

Name:

Value Type:

Value:

OK Cancel

Name

Allows to type the **Name** of the input value.

Value Type

Allows to select the **Value Type** for the input value.

Value

Allows to type the value name in the box.

Remove Allows to remove the Voicebot input values. Edit

Allows to edit the Voicebot input values,

Voicebot selection

From the Voicebot selection, the Agent can select the Project Name and voicebot version.

Voicebot input values the caller intent and fill the slots (For example, the bot matches the caller spoken responses with the intent schedule an appointment and a filled slot of 10:00 am for the time).

When the bot completes the interaction, the call routes back into the Interaction Attendant flow, the intent, and slot values are captured into call attributes, and the Interaction Attendant existing capabilities then the Voicebot allow the flow to operate based on the filled intent and slot data.

Full View of Voicebot Voicebot selection dialog

The options in this Voicebot selection, gives the option to select the Voicebot ID.

Voicebot details

Voicebot details provide the information to implement the Attendant/Handlers.

Voicebot input values add/edit dialog The value can be either a literal Text string or the name of a call attribute. If the value is typed as **Attribute** the specified call attribute will be queried at runtime and passed to the bot. This provides a powerful mechanism for passing data such as calling number to the bot. Voicebot Outputs

Before running the voicebot the Interaction Attendant runtime sets the value of all call attributes beginning with **Eic_Voicebot** to an empty string. This simplifies the use case where the call may be processed by multiple voicebot invocations.

After running the voicebot the **Eic_Voicebot_Intent** call attribute is set to the value of the intent indicated by the voicebot. Each returned slot value is set as the value of an attribute formed from the string **Eic_Voicebot_Slot_** followed by the slot name. Each returned output value is set as the value of an attribute formed from the string **Eic_Voicebot_Output_** followed by the output name.

Action When Finished frame

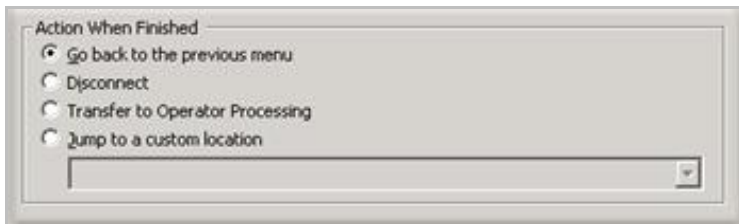

Go back to the previous menu radio button

The *Go back to the previous menu* option returns control to the parent menu from which the message was played.

The Go back to the previous menu option

Sets up a simple loop that "reruns" the parent menu from the top.

Disconnect radio button

This option disconnects the call after replaying the wave file the number of times that is specified by the repeat value.

Transfer to Operator Processing

Transfers the call for evaluation by operator profiles defined for this server.

Jump to radio button

This option allows you to jump to any [profile](#), [schedule](#), [menu](#), or [operation](#) that is defined for the current server. Flow of control will pass to this destination once the wave file has been played the number of time specified by the repeat value.

Modify CustomSubroutineInitiatorRouter.ihd

This procedure explains how to modify CustomSubroutineInitiator.ihd handler in Interaction Designer to specify a subroutine to invoke. This must be done before you can use [Run Subroutine](#) nodes in your menus.

Before performing this procedure, the subroutine to be called must exist on the server, and you must know its name. It is assumed that the reader has some experience with Interaction Designer. You may find it helpful to consult the Designer help system as you perform this procedure. You may wish to obtain assistance from an experienced handler developer. To modify the handler, follow these steps:

1. Open Interaction Designer.
2. Open the File menu, select Open, navigate to \IC\I3\IC\handlers\40handlers\CustomSubroutineInitiatorRouter.ihd, and click Open. The CustomSubroutineInitiatorRouter.ihd opens.

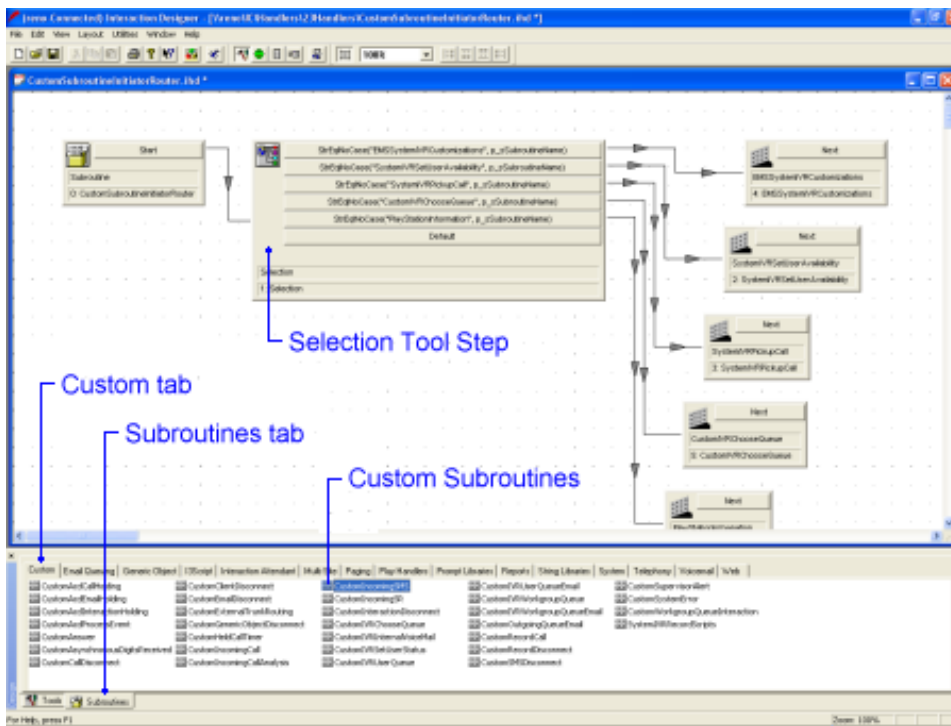

Note: If you have multiple custom subroutines, you will have to call your own selection tool steps. For example, if you have three custom subroutines, you must hook up a selection step and enter the appropriate name in Interaction Attendant.

3. From the Tools tab, located at the bottom corner of the Design pallet, click the Basic tab and drag a Selection tool step to the Design area, and then double-click the Selection tool step. The Properties of Selection dialog opens.

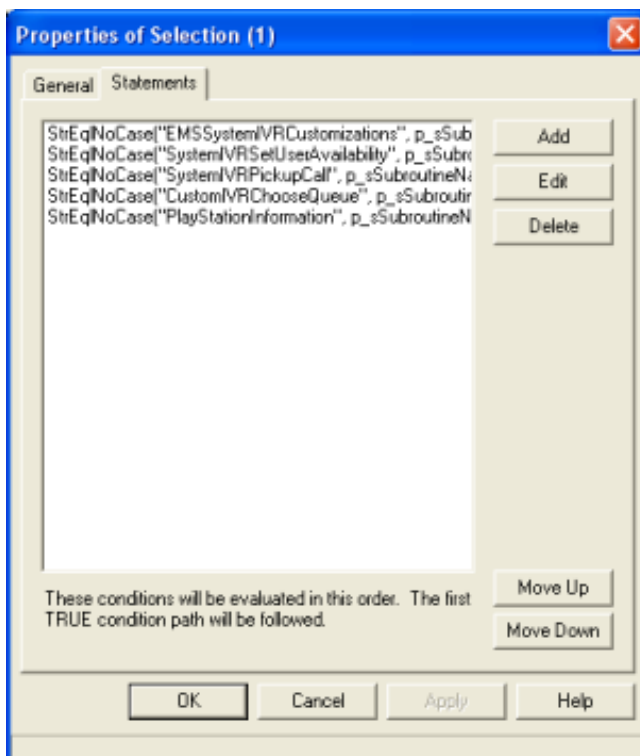

4. Click the Statements tab, and then click the Add button. The Edit Expression dialog opens.

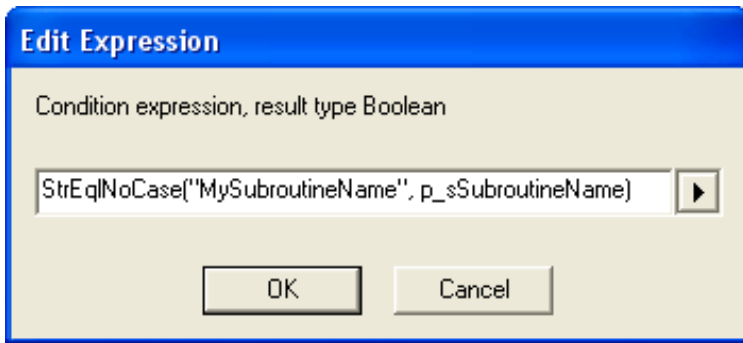

5. In the Condition expression, result type Boolean field, type:

StrEqNoCase("MySubroutineName", p_sSubroutineName)

Note: Replace **MySubroutineName** with the name of a custom subroutine you want to call from Attendant using a Run Subroutine node. This conditional expression identifies a subroutine for **CustomSubroutineInitiatorRouter** to invoke.

6. Click OK to close the Edit Expression dialog.
7. Click OK to close the Properties of Selection tool step.
8. Click the Subroutines tab, located at the bottom corner of the Design palette, and select the Custom tab.
9. Locate the custom subroutine whose name you specified in step 5. Drag and drop its tool icon into the Design window so that it is positioned to the right of the Selection tool step.
10. Connect the Selection tool to the subroutine by clicking and dragging between the icons. Your screen should look similar to the following:

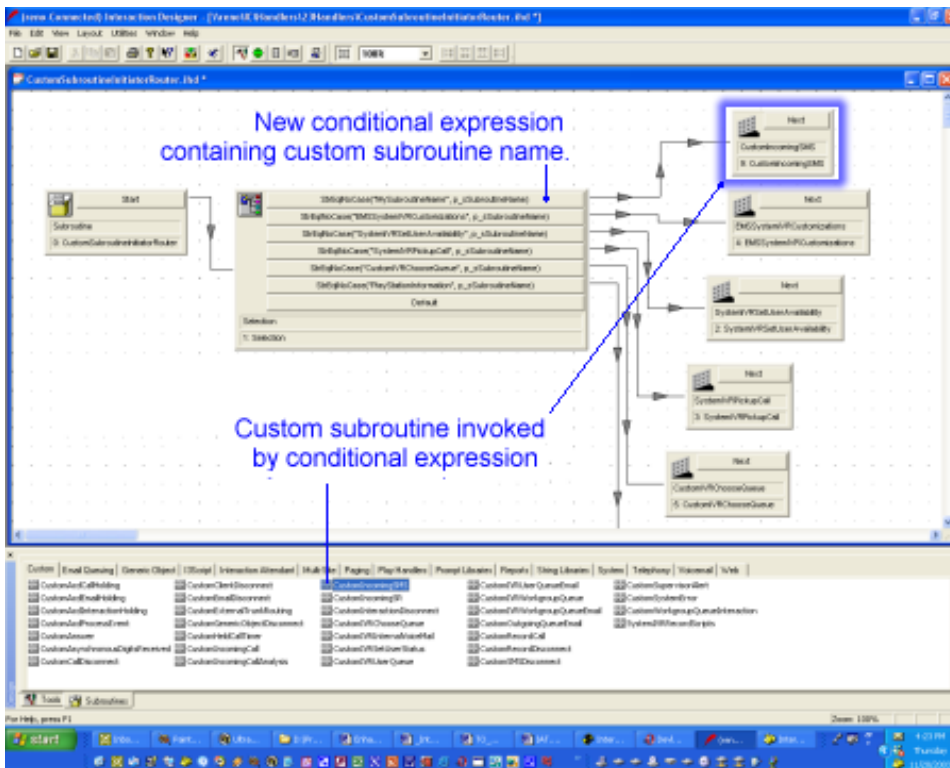

11. Look for a green "happy face" icon in the toolbar. Green indicates that the handler is ready to publish.

Note: If the icon is Yellow or Red, do not proceed until you have located the source of the error. Consult the Designer online help for more information.

12. Open the File menu and select **Save**.
13. Press the **Publish** toolbar button, or open the File menu and select **Publish**, to republish **CustomSubroutineInitiatorRouter.ihd**.

Note: You can now use the Run Subroutine nodes in Interaction Attendant to call the subroutine. If your custom subroutine transfers the call to another thread (e.g. does not return the call to Attendant), the subroutine should set a Boolean return value named `p_bTransferred`. Set its value True if the call was transferred, or False if the call will be returned to Interaction Attendant for further processing (in other words, True indicates that the call was transferred). See [Run Subroutine](#) for details.

Related Topics

[Run Subroutine](#)

Screen Pop

Screen Pop executes an **action** previously configured using the *Actions* container in Interaction Administrator. Actions can be thought of as a direct communications link between two application programs. Data is passed to a third party application to perform some action. For example, a URL can be passed to a web browser.

Three types of screen pop actions can be defined in Interaction Administrator: DDE, Web Browser Screen Pop, and Custom Screen Pop. Web Browser Screen Pop uses the same internal configuration as a custom screen pop, but has a separate configuration dialog for easy configuration.

In addition, scripts created in RightNow's ScriptAssist appear as actions in Interaction Administrator's Actions container. When a ScriptAssist script is saved, it appears in Interaction Administrator's Actions container, and the script is also visible to Screen Pop nodes in Interaction Attendant.

Note—Interaction Attendant does not support DDE actions.

Once actions are defined in Interaction Administrator or optionally in ScriptAssist, an Attendant profile can be set up to call a screen pop action. The default values for the selected screen pop can be overridden to pass different values to the application. For example, you might change the URL of a Web Browser Screen Pop action selected in Attendant, to open a different web page. Override is allowed if the action is configured in Interaction Administrator to allow values to be changed in Attendant.

The Interaction Administrator Help explains how to define actions. This topic explains how to invoke an action from Attendant.

Node Characteristics frame

Options in this frame name the node, assign the digit used to select it, and establish whether or not it is active, used by default, logged, or tracked for reporting purposes.

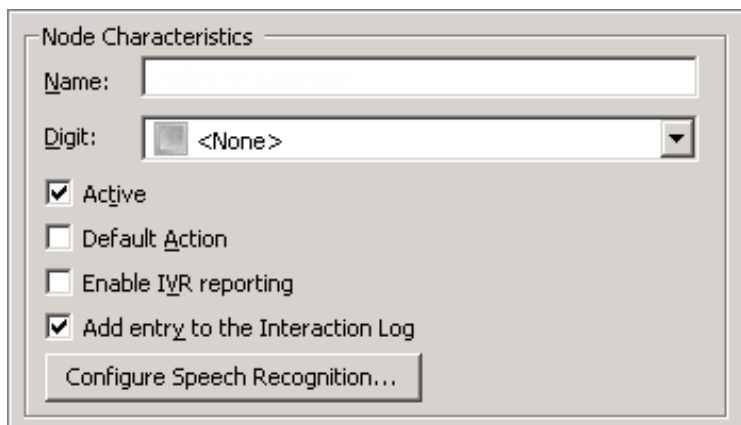

Name field

The label you enter here becomes the name of the node in the tree structure.

Digit list box

Use this list to select the key that callers press to enter a caller data entry operation. When you assign a digit, the list displays only available digits—those that are not already in use at this level of the tree. If no digit is assigned, callers cannot invoke the operation directly. It is possible to create menu options that are invoked by a routing process, rather than by a user selection. For details, see [invoke a menu operation automatically](#).

Active check box

By default, forms are "on", or "active", which means that Interaction Attendant will process them. If you uncheck a form's Active check box, the name of the node turns gray in the tree to indicate that the form is inactive. Interaction Attendant and its [handlers](#) will thereafter ignore the form and its children. Use this feature to save a configuration that you are testing. Inactive forms are invisible to callers. When a node is inactive, it appears grayed out in the tree view.

Default Action check box

At any given "level" in the tree structure, one node can be marked as the default action. The operation defined by the [default node](#) is performed if the caller does not press a key within the timeout period specified by that menu. The icon for default forms has a green border in the tree structure. Any node below a menu or schedule can be marked as the [default action](#), by checking the form's default action check box.

Enable IVR Reporting

This option determines whether or not reporting data will be collected when control passes through this node. Several IVR Reports summarize this information. IVR Reporting is *disabled* by default. Enable it to capture the date, time and duration of time that the call remained in the node and its children. This option is hidden when Attendant is connected to a server that does not have reporting installed. For more information about this feature, see [IVR Reporting Option](#).

Add entry to the Interaction Log

When this option is enabled, information about this node is appended to the call's Interaction Log when the call enters this node. This helps track the path that a call took through Attendant. The Interaction Log is maintained for reporting purposes. See [View the Interaction Log](#) for details.

Configure Speech Recognition... button

Select this button to configure words or phrases that can be associated with menu options. Callers can verbally indicate the options they want in the IVR instead of pressing a digit on the phone. You can enter multiple words and phrases for each menu item, just as callers may phrase the same request in different ways. For example, "transfer funds" or "funds transfer". See [Add Speech Recognition keywords or phrases to Inbound Call Operations](#).

Screen Pop Action and Values

Name	Value
Home Page	http://www.inin.com
Support Site	http://www.inin.com/support/

Screen Pop Action

Screen Pop Action lists entries from the *Actions* container in Interaction Administrator. Since Interaction Attendant does not support DDE actions, those are not displayed in this list. If you add or update Actions in Interaction Administrator while using Interaction Attendant, you must restart Interaction Attendant to view changes.

Name/Value pairs

This list is populated if the action selected in the *Screen Pop Action* drop list contains input values to pass to the application popped. Depending upon the override settings set for the Action in Interaction Administrator, you can edit these values by typing in different values or select a predefined multiple-choice value.

For example, you might change the URL of a Web Screen Pop action to specify a different page, or change the value of parameters used by script actions.

Edit button

Opens the selected Name/Value pair so that you can edit or select the value passed to the application.

Screen Pop Input Configuration [?] [X]

Name:

Friendly Name:

Override (Attendant):

Override Values:

- New Support Site
- Support

Add...
Edit...
Remove

The checked item in this list is the default value.

OK Cancel

If in Interaction Administrator, *Allow override with selected values (Multiple Choice)* was selected when the value was defined (as shown above) then you can select one value to pass to the application after clicking *Edit* in Interaction Attendant:

Select an override value [X]

Name: Support Site

Value:

- New Support Site
- Support

OK Cancel

Conversely, if *Allow Override* was selected when the entry was defined in Interaction Administrator, you can edit the entry by typing a new value manually. The image below shows a value that can be manually overridden in Attendant:

Screen Pop Input Configuration [?] [X]

Name:

Friendly Name:

Override (Attendant):

Default Value:

OK Cancel

When *Edit* is clicked, the dialog allows a new entry to be typed:

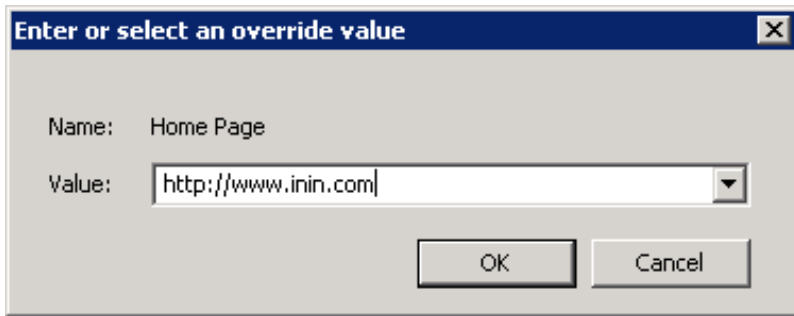

Tip: To set the URL parameter to the value of a custom call attribute, type $\$(attr_name)$ in the *Value* field, after replacing *attr_name* with the value of the custom call attribute. This allows the parameter to be populated with a call attribute set earlier in the Attendant flow.

For overridable or static input values, static items can be selected from the drop list in Attendant:

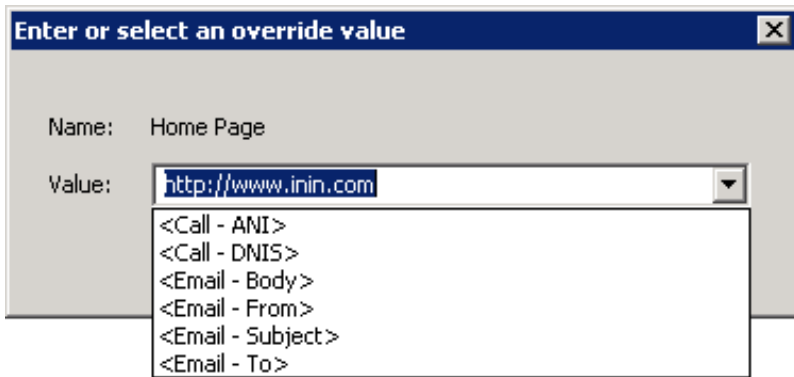

These pass dynamic information to the application popped instead of a predefined string value.

Action When Finished

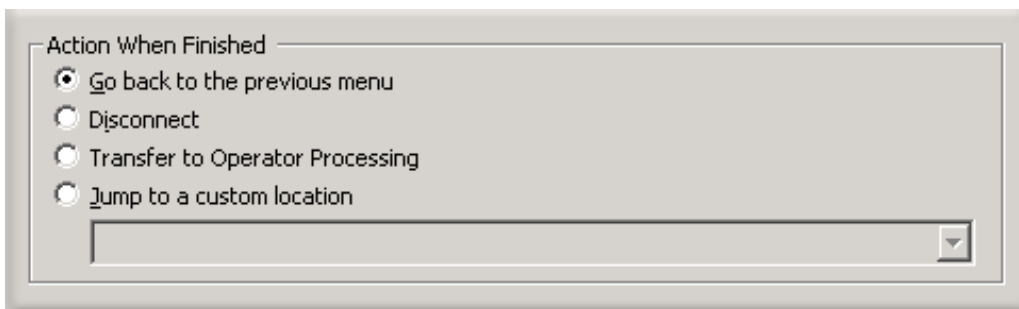

Sets the finishing path to take when this node executes successfully.

Reset button

For the selected action, resets any override value to the default value of the action.

Reset All button

For all listed actions, resets any overridden value to default values.

Go back to previous menu

This option sets up a simple loop that "reruns" the menu from the top.

Disconnect

This option disconnects the call when the operation is completed successfully.

Transfer to Operator Processing

Transfers the call for evaluation by operator profiles defined for this server.

Jump to a custom location

This option allows you to jump to any [profile](#), [schedule](#), [menu](#), or [operation](#) that is defined for the current server.



Configure a Selection Node

A Selection action branches on condition after evaluating one or more expression cases. This action is similar to a [Logical Transfer](#), but is easier to set up when multiple expression cases must be evaluated. Selection nodes are easier to understand because there are no jumps to other nodes in the tree view. The Selection action works like a C++ switch statement, or a Visual Basic Select Case statement, if you are familiar with programming concepts.

For example, a company which offers three levels of technical support (Bronze, Silver, or Gold) could store an interaction's support level in an attribute, and later use a Selection node to examine the value of that attribute to take different actions.

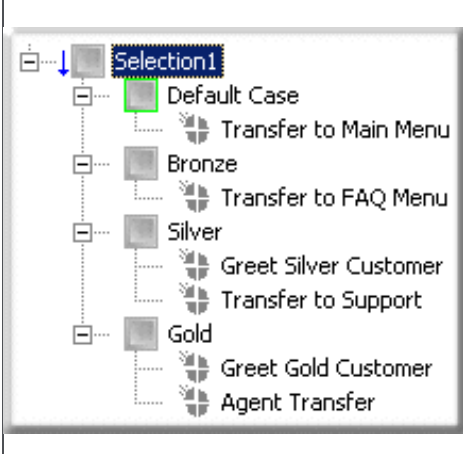
	<p>The figure at left shows Expression Case nodes below the Selection action and displays child operations to perform for each possible case. In this example:</p> <p>Default Case: If the value of the attribute is not Bronze, Silver, or Gold, the Default Case expression case is selected, which in this example transfers the interaction to a Main Menu.</p> <p>Bronze: An expression case was created to transfer Bronze interactions to a FAQ menu.</p> <p>Silver: An expression case was created to direct the system to send Silver interactions (in this example, calls) a customized greeting message on their way to the Support queue.</p> <p>Gold: An expression case was created to direct the system to transfer Gold interactions (in this example, calls) to an Agent's queue after first receiving their own custom greeting.</p>
---	--

Selection actions make it easy to set up multiple branches based upon evaluation of flexible expression criteria.

Configure a Selection Node

1. Add a **Selection** node. In the **Name** field, type a meaningful name for the selection action.
2. Click the **Digit** drop down list and select a number to assign to the selection action. This is the key that callers press to select the menu entry. When you assign a digit, the only available digits are those that are not already in use at this level of the tree. If you do not assign a digit, callers cannot invoke the operation directly.

Note: The **Digit** drop down list is not available for e-mail interactions, and does not appear in E-mail Configuration files.

3. Place a check mark in any **Node Characteristics** that apply:

Checkbox	Description
Active	By default, this field contains a check mark, which means the form is "on", or "active" and Interaction Attendant will process them. If you un-check a form's Active check box, the name of the form turns gray in the tree to indicate that the form is inactive. Interaction Attendant and its handlers will ignore the form and its children. Leave the box unchecked to save a configuration that you are testing. Inactive forms are unavailable to interactions
Default Action	At any given level in the tree structure, one node can be marked as the default action. The operation defined by the default node is performed if callers do not press a key within the timeout period specified by that menu. The icon for default forms has a green border in the tree structure. Any node below a menu or schedule can be marked as the default action , by checking the form's default action check box. Note: The Default Action check box is not available for e-mail interactions, and does not appear in E-mail Configuration files.
Enable IVR Reporting	This option determines whether or not reporting data will be collected when control passes through this node. Several IVR Reports summarize this information. IVR Reporting is <i>disabled</i> by default. Place a check mark in this box to capture the date, time and duration of time that the interaction remained in the node and its children. This option is hidden when Attendant is connected to a server that does not have reporting installed. For more information about this feature, see IVR Reporting Option .
Add entry to the Interaction log	When this option is enabled, information about this node is appended to the interaction's Interaction Log when the interaction enters this node. This helps track the path that an interaction took through Attendant. The Interaction Log is maintained for reporting purposes. See View the Interaction Log for details.
Configure Screen Recognition button	Select this button to configure words or phrases that can be associated with menu options. Callers can verbally indicate the options they want in the IVR instead of pressing a digit on the phone. You can enter multiple words and phrases for each menu item, just as callers may phrase the same request in different ways. For example, "transfer funds" or "funds transfer". See Add Speech Recognition keywords or phrases to Inbound Call Operations .

4. **For Inbound, Outbound, or Operator calls only**, set up the expression criteria:
 - a. Click **Create Expression Criteria** to set up the left hand of the expression, or what is evaluated. The [Expression Type Wizard](#) opens. You can create an expression using the following data types:
 - Data previously entered by the caller
 - Data about the current call
 - The current time
 - Data about a particular workgroup (ACD or Custom)
 - Data from a database
 - b. Select a data type. Then click **Next** or **Finish** based on the options available for the data type selected. You may be prompted to select or enter specific data. For example, if you select *Data about the current call*, you must click *Next* to specify the name of a call attribute (see the following figure). Conversely, if you select *The current time*, you can click *Finish* immediately since no additional information must be supplied.

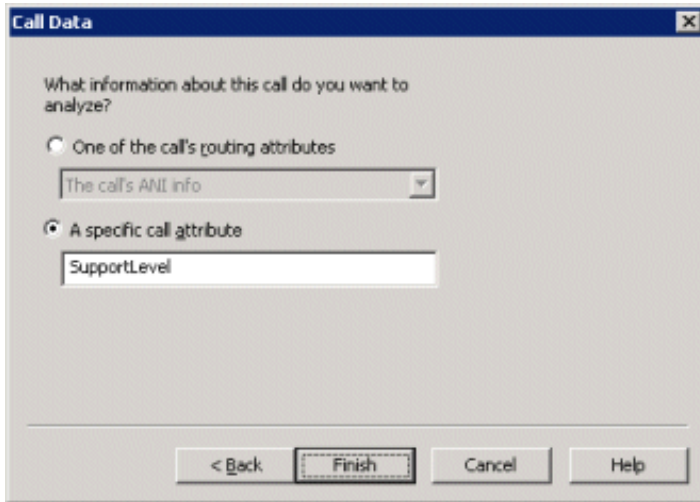

The Call Data dialog opens when you select Data about the current call.

Note: The resulting Expression Criteria will appear as read-only text. Note that the Selection node is in error until valid expression criteria is defined.

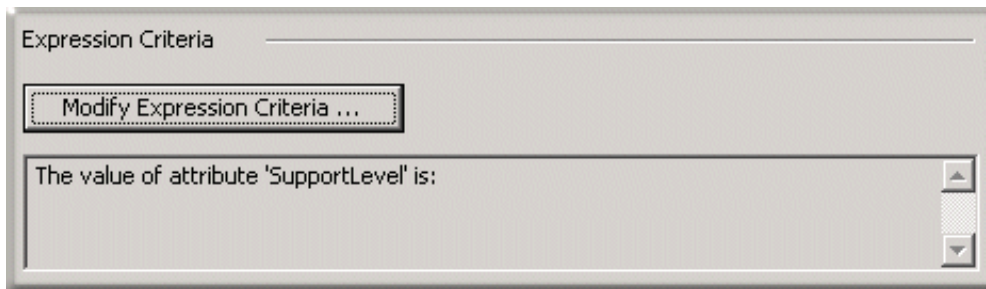

5. The next step is to add expression cases. For instructions, see [Configure an Expression Case](#).

Related Topics

- [Configure an Expression Case](#)

Configure an Expression Case

An Expression Case is a node that contains defined conditional processing for a parent [Selection](#) action. Before you can define case nodes, you must first [Configure a Selection Node](#).

In the tree view, **Expression Cases** appear as nodes underneath the **Selection** action. This makes it easy to see all of the available paths that can be taken. In addition, a **Default Case** appears below the selection node. If all other expression cases evaluate false, routing will take the path below that case. Each case behaves like a multi-action container where actions can be placed underneath, and they are processed in top down order like that of an e-mail profile. Whenever a new selection action is added to the tree view, a default case is added underneath it as well.

	<p>The figure at left shows Expression Case nodes below the Selection action and displays child operations to perform for each possible case. In this example:</p> <p>Default Case: If the value of the attribute is not Bronze, Silver, or Gold, the Default Case expression case is selected, which in this example transfers the interaction to a Main Menu.</p> <p>Bronze: An expression case was created to transfer Bronze interactions to a FAQ menu.</p> <p>Silver: An expression case was created to direct the system to send Silver interactions (in this example, calls) a customized greeting message on their way to the Support queue.</p> <p>Gold: An expression case was created to direct the system to transfer Gold interactions (in this example, calls) to an Agent's queue after first receiving their own custom greeting.</p>
--	--

Configure an Expression Case

1. Set up a **Selection** node. For instructions, see [Configure a Selection Node](#).
2. Select the newly created selection node and under **Expression Cases** click **Add**. The **Case Edit** dialog opens.

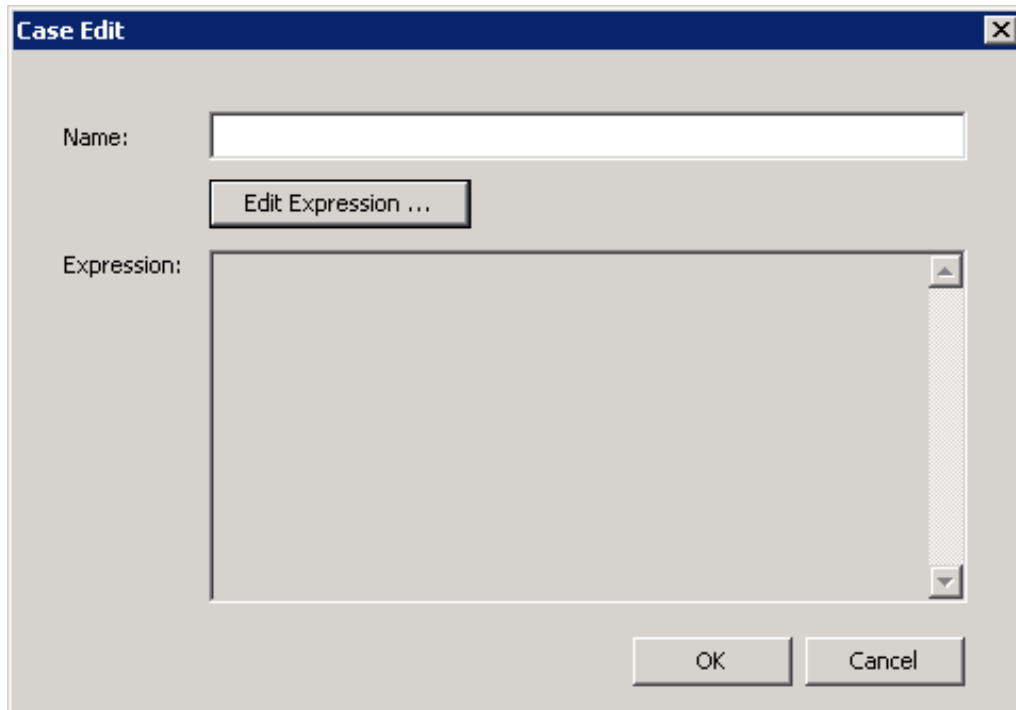

3. Set up the **Expression Case**:
 - To set up an expression case for **Inbound**, **Outbound**, or **Operator Configurations**:
 - In the **Name** field, type a meaningful name for the expression case and then click **Edit Expression**. The **Call Properties** dialog opens.

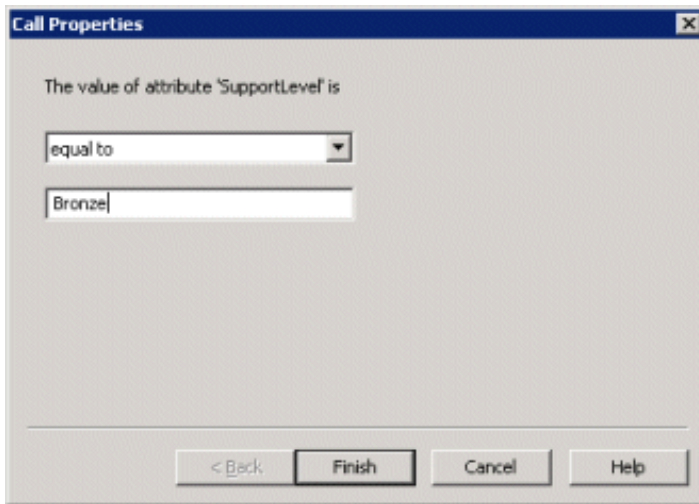

- Click the **The value of attribute '[attribute name]'** drop down list and select one of the following operators:
 - a. Greater than
 - b. Greater than or equal to
 - c. Equal to
 - d. Less than or equal to
 - e. Less than
 - f. Before (applies to data/time criteria only)
 - g. After (applies to data/time criteria only)
- In the field below the **The value of attribute '[attribute name]'** drop down list, enter a value against which to compare the expression criteria (in the example above: Bronze, Silver, or Gold). Click **Finish**.
- To set up an expression case for **E-mail Configurations**:
 - In the **Name** field, type a meaningful name for the expression case and then click **Edit Expression**. The **Email Conditions** dialog opens.

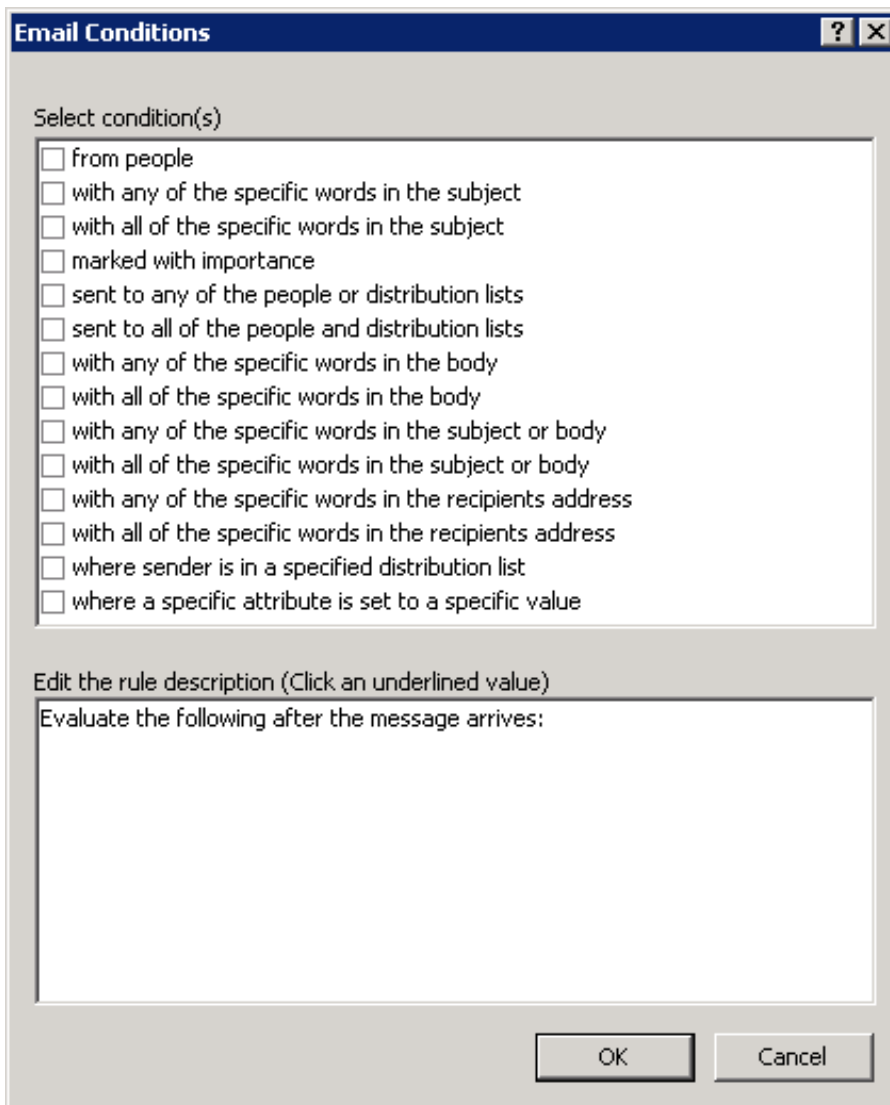

- o In the **Select condition(s)** area, select one or more criteria to apply to the expression.
- o In the **Edit the rule description (Click an underlined value)** area, click the hyperlink(s) associated with each rule to specify how the e-mail is evaluated upon arrival.

Note: The next dialog box to appear will differ, depending on the criteria you select. For example, if you select the **marked with importance** condition check box, "and marked with **specific importance**" appears in the **Edit the rule description** area, and the word "**specific**" contains a hyperlink. When you click the **specific** hyperlink, the **Importance Level** dialog opens, and you can specify the degree of importance to place on the e-mail.

- o Configure each rule description and then click **OK** to close the **Email Conditions** dialog.
4. Click **OK** to close the **Case Edit** dialog.
 5. To define additional cases, click the **Selection** node, and then click **Add**. You can only create case nodes by clicking **Add** on the selection node form view. Interaction Attendant does not contain a toolbar or menu item for adding case nodes.
 6. Select an expression case and use the toolbar or Insert menu to **add an operation node** that determines what action each branch should take if an interaction meets the case criteria. Repeat this procedure for each expression case. In the following

example, Play Audio, Menu Transfer, and Agent Transfer nodes were added.

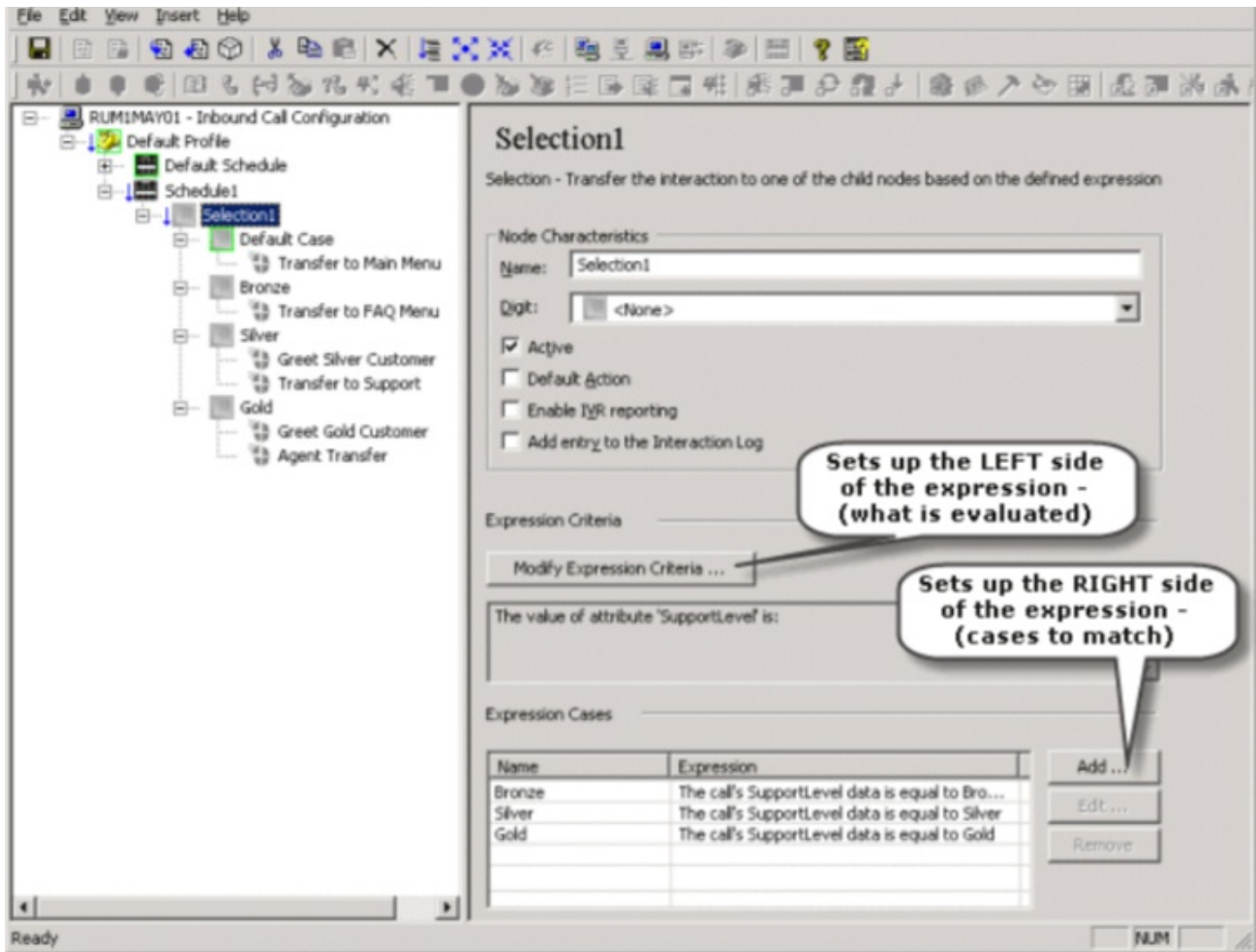

7. Place a check mark in any Node Characteristics that apply:

Checkbox	Description
Active	By default, this field contains a check mark, which means the form is "on", or "active" and Interaction Attendant will process them. If you un-check a form's Active check box, the name of the form turns gray in the tree to indicate that the form is inactive. Interaction Attendant and its handlers will ignore the form and its children. Leave the box unchecked to save a configuration that you are testing. Inactive forms are unavailable to interactions
Default Action	At any given level in the tree structure, one node can be marked as the default action. The operation defined by the default node is performed if callers do not press a key within the timeout period specified by that menu. The icon for default forms has a green border in the tree structure. Any node below a menu or schedule can be marked as the default action , by checking the form's default action check box. Note: The Default Action check box is not available for e-mail interactions, and does not appear in E-mail Configuration files.
Enable IVR Reporting	This option determines whether or not reporting data will be collected when control passes through this node. Several IVR Reports summarize this information. IVR Reporting is <i>disabled</i> by default. Place a check mark in this box to capture the date, time and duration of time that the interaction remained in the node and its children. This option is hidden when Attendant is connected to a server that does not have reporting installed. For more information about this feature, see IVR Reporting Option .
Add entry to the Interaction log	When this option is enabled, information about this node is appended to the interaction's Interaction Log when the interaction enters this node. This helps track the path that an interaction took through Attendant. The Interaction Log is maintained for reporting purposes. See View the Interaction Log for details.
Configure Screen Recognition button	Select this button to configure words or phrases that can be associated with menu options. Callers can verbally indicate the options they want in the IVR instead of pressing a digit on the phone. You can enter multiple words and phrases for each menu item, just as callers may phrase the same request in different ways. For example, "transfer funds" or "funds transfer". See Working with Speech Recognition for details.

Related Topics

- [Configure a Selection Node](#)



Set Attribute

Telephones calls (and other objects in CIC) can have attributes assigned to them. An attribute is a piece of information about an object that travels with it throughout Customer Interaction Center. For example, one attribute of a call object is the telephone number of the person who placed the call. Each attribute is a name/value pair. To set an attribute, specify its name and a string value you wish to assign to the attribute.

The Set Attribute operation can assign a value to any attribute, including attributes that are reserved for use by important handlers in the Customer Interaction Center. If you modify a reserved attribute, you can adversely affect the performance or reliability of the server, so you should set attributes carefully.

The *Interaction Attributes Technical Reference* reports attributes that are reserved by CIC, including those which should not be changed.

Node Characteristics frame

Options in this frame name the node, assign the digit used to select it, and establish whether or not it is active, used by default, logged, or tracked for reporting purposes.

Name field

The label you enter here becomes the name of the node in the tree structure.

Digit list box

Use this list to select the key that callers press to enter a caller data entry operation. When you assign a digit, the list displays only available digits—those that are not already in use at this level of the tree. If no digit is assigned, callers cannot invoke the operation directly. It is possible to create menu options that are invoked by a routing process, rather than by a user selection. For details, see [invoke a menu operation automatically](#).

Active check box

By default, forms are "on", or "active", which means that Interaction Attendant will process them. If you uncheck a form's Active check box, the name of the node turns gray in the tree to indicate that the form is inactive. Interaction Attendant and its [handlers](#) will thereafter ignore the form and its children. Use this feature to save a configuration that you are testing. Inactive forms are invisible to callers. When a node is inactive, it appears grayed out in the tree view.

Default Action check box

At any given "level" in the tree structure, one node can be marked as the default action. The operation defined by the [default node](#) is performed if the caller does not press a key within the timeout period specified by that menu. The icon for default forms has a green border in the tree structure. Any node below a menu or schedule can be marked as the [default action](#), by checking the form's default action check box.

Enable IVR Reporting

This option determines whether or not reporting data will be collected when control passes through this node. Several IVR Reports summarize this information. IVR Reporting is *disabled* by default. Enable it to capture the date, time and duration of time that the call remained in the node and its children. This option is hidden when Attendant is connected to a server that does not have reporting installed. For more information about this feature, see [IVR Reporting Option](#).

Add entry to the Interaction Log

When this option is enabled, information about this node is appended to the call's Interaction Log when the call enters this node. This helps track the path that a call took through Attendant. The Interaction Log is maintained for reporting purposes. See [View the Interaction Log](#) for details.

Configure Speech Recognition... button

Select this button to configure words or phrases that can be associated with menu options. Callers can verbally indicate the options they want in the IVR instead of pressing a digit on the phone. You can enter multiple words and phrases for each menu item, just as callers may phrase the same request in different ways. For example, "transfer funds" or "funds transfer". See [Add Speech Recognition keywords or phrases to Inbound Call Operations](#).

Attribute and Value fields

These fields identify the attribute to set, and assign a value to it.

Attribute text box

Type the name of the attribute in this text box. This name can be anything you like, or it can be the name of a reserved attribute. For more information about attributes, refer to the *Interaction Attributes Technical Reference* located in the PureConnect Documentation Library.

Value

Type the text you wish to assign to the attribute in this field. This can be anything you like. For example, "This interaction was processed by Attendant."

Tips for Advanced Users

Some reserved attributes allow you to organize and manage characteristics appropriate for specific interactions. For example, you can specify which workgroups or agents receive an interaction, you can combine skills to create a unique skill set, you can assign priority value for interactions sent to a workgroup, and you can define an external telephone number to which designated interactions are sent.

- **Eic_AttDynamicWorkgroupName**. Use this attribute to organize multiple workgroups. For example, you can define your workgroups by area of expertise, such as web service calls or custom handler calls.
- **Eic_AttDynamicWorkgroupSkills**. Defines a skill set based on two or more defined skills. The skills designated in this attribute must be separated using the pipe-delimited format. For example, if you want to specify that agents assigned to this interaction attribute contain multiple language skills, enter the value for this attribute as "Spanish|French|Norwegian".
- **Eic_AttDynamicWorkgroupPriority**. Assigns priority value for interactions specified for a specific workgroup.
- **Eic_AttDynamicAgentName**. Specifies the agent or user to which specific interactions are sent.
- **Eic_AttDynamicExternalNumber**. Defines the external telephone number to which designated interactions are transferred.

In addition, since the handler that supports Set Attribute node processes values through the ReplaceAttributes tool before it sets the target attribute, the Set Attribute node can be used to assign one attribute value to another, or to insert the value of an attribute along with a string literal. The syntax for inserting an attribute value is "\${attributename}".

To copy one attribute value into another:

Attribute name: SOME_ATTRIB
Value: \$(SOME_OTHER_ATTRIB)

To copy literal text and an attribute value into another attribute:

Attribute name: SOME_ATTRIB
Value: The phone number is \$(SOME_OTHER_ATTRIB)

Action When Finished frame

These options set the processing that occurs after the operation completes successfully, when flow of control leaves the node. You can return control to the previous menu, disconnect the call, transfer to an operator profile, or jump to any node or action that has been defined for the current server.

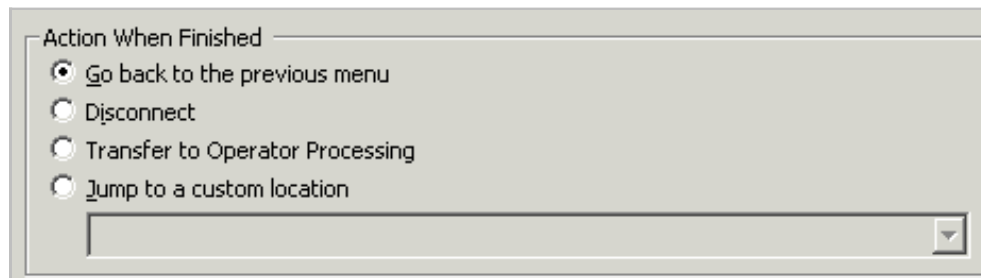

Go back to previous menu

This option returns control to the parent menu. This sets up a simple loop that "reruns" the menu from the top.

Disconnect

This option disconnects the call when the data entry operation is completed successfully.

Transfer to Operator Processing

Transfers the call for evaluation by operator profiles defined for this server.

Jump to Next Node

This choice is available when the parent node is a Multi-Action Container. It continues processing at the next node in the container.

Jump to a custom location

This option allows you to jump to any [profile](#), [schedule](#), [menu](#), or [operation](#) that is defined for the current server.

Set Advanced Statistic

This action is used for logging report data or statistic data within an IVR. The CIC server generates advanced statistics about interactions and reports these statistics. CIC provides this functionality by using report group and statistic group assignments.

The **Set Advanced Statistic** action in Attendant allows values to be logged in a report group or a statistic group. This action should be used prior to a transfer to a workgroup or user queue in an IVR configuration. This action is available in all profile types (i.e. inbound, outbound, operator, email). It provides a way to log actions or paths taken to arrive at (workgroup or user) queue transfers in an IVR for reporting purposes.

Report Groups must be set before transferring an interaction into a queue. Do not set a report group after the queue transfer has been performed.

For background information about Report groups and Statistic groups, see *CIC Report Groups and Statistic Groups* in the *PureConnect Reporting Technical Reference* in the PureConnect Documentation Library.

Node Characteristics frame

Options in this frame name the node, assign the digit used to select it, and establish whether or not it is active, used by default, logged, or tracked for reporting purposes.

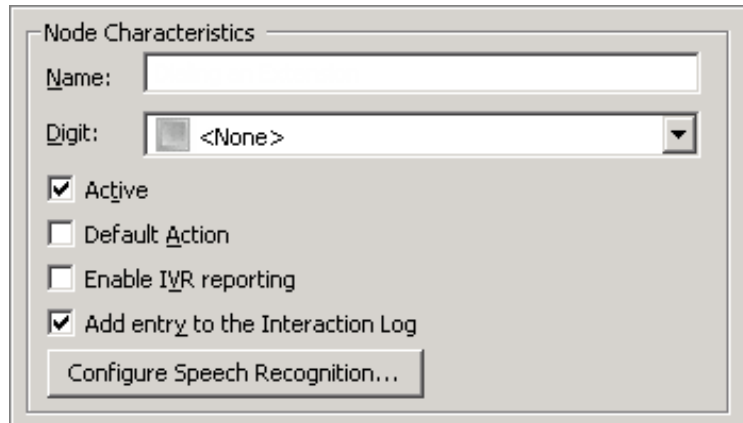

The screenshot shows a dialog box titled "Node Characteristics". It has a "Name:" label followed by a text input field. Below that is a "Digit:" label followed by a dropdown menu showing "<None>". There are four checkboxes: "Active" (checked), "Default Action" (unchecked), "Enable IVR reporting" (unchecked), and "Add entry to the Interaction Log" (checked). At the bottom is a button labeled "Configure Speech Recognition...".

Name field

The label you enter here becomes the name of the node in the tree structure.

Digit list box

Use this list to select the key that callers press to enter a caller data entry operation. When you assign a digit, the list displays only available digits—those that are not already in use at this level of the tree. If no digit is assigned, callers cannot invoke the operation directly. It is possible to create menu options that are invoked by a routing process, rather than by a user selection. For details, see [invoke a menu operation automatically](#).

Active check box

By default, forms are "on", or "active", which means that Interaction Attendant will process them. If you uncheck a form's Active check box, the name of the node turns gray to indicate that the form is inactive. Interaction Attendant and its [handlers](#) will thereafter ignore the form and its children. Use this feature to save a configuration that you are testing. Inactive forms are invisible to callers. When a node is inactive, it appears grayed out in the tree view.

Default Action check box

At any given "level" in the tree structure, one node can be marked as the default action. The operation defined by the [default node](#) is performed if the caller does not press a key within the timeout period specified by that menu. The icon for default forms has a green border in the tree structure. Any node below a menu or schedule can be marked as the [default action](#), by checking the form's default action check box.

Enable IVR Reporting

This option determines whether or not reporting data will be collected when control passes through this node. Several IVR Reports summarize this information. IVR Reporting is *disabled* by default. Enable it to capture the date, time and duration of time that the call remained in the node and its children. This option is hidden when Attendant is connected to a server that does not have reporting installed. For more information about this feature, see [IVR Reporting Option](#).

Add entry to the Interaction Log

When this option is enabled, information about this node is appended to the call's Interaction Log when the call enters this node. This helps track the path that a call took through Attendant. The Interaction Log is maintained for reporting purposes. See [View the Interaction Log](#) for details.

Configure Speech Recognition... button

Select this button to configure words or phrases that can be associated with menu options. Callers can verbally indicate the options they want in the IVR instead of pressing a digit on the phone. You can enter multiple words and phrases for each menu item,

just as callers may phrase the same request in different ways. For example, "transfer funds" or "funds transfer". See [Add Speech Recognition keywords or phrases to Inbound Call Operations](#).

Assign To frame



Selects a group type to assign a value to.

Statistic Group

Allows assignment of a value to a statistics group. The statistic value will be written to the **IStatGroup** table in the reporting database. The value will be written in the **cName** column.

Report Group

Allows assignment of a value to a custom report group. Data will be written to the **IWrkGrpQueueStats** and the **IAgentQueueStats** tables in the reporting database. The value will be written to the **CReportGroup** column. You can view Report group data in Report Assistant by:

1. Select the "Workgroup Queue Statistics (Custom Groups)" package
2. Select the "Report Group" field
3. Select the workgroup that is referenced (i.e. calls are being transferred to) in the IVR configuration.

Statistic Value

The string value assigned to the statistic group or report group. This is arbitrary text that identifies the path taken by the call.

Actions When Finished frame

Options in this frame set the flow of control that occurs when the user escapes from the Workgroup Queue.

Go back to the previous menu radio button

The *Go back to the previous menu* option sets up a simple loop that "reruns" the parent menu from the top. It returns control to the parent menu from which the message was played.

Disconnect

Terminates the call.

Transfer to Operator Processing

Transfers the call for evaluation by operator profiles defined for this server.

Jump to a custom location radio button

Use this option to jump to any [profile](#), [schedule](#), [menu](#), or [operation](#) that is defined for the current server.



Transfer to a Different Menu

This operation transfers a call to another menu within the same profile or another profile. (These profiles must both exist on the same server.) For example, suppose you create a complex set of submenus that you will use in all profiles. Instead of creating the same menu structure repeatedly in every profile, transfer a call to this special subset. This allows a single menu to be shared by all profiles.

Node Characteristics frame

Options in this frame name the node, assign the digit used to select it, and establish whether or not it is active, used by default, logged, or tracked for reporting purposes.

Name field

The label you enter here becomes the name of the node in the tree structure.

Digit list box

Use this list to select the key that callers press to enter a caller data entry operation. When you assign a digit, the list displays only available digits—those that are not already in use at this level of the tree. If no digit is assigned, callers cannot invoke the operation directly. It is possible to create menu options that are invoked by a routing process, rather than by a user selection. For details, see [invoke a menu operation automatically](#).

Active check box

By default, forms are "on", or "active", which means that Interaction Attendant will process them. If you uncheck a form's Active check box, the name of the node turns gray in the tree to indicate that the form is inactive. Interaction Attendant and its [handlers](#) will thereafter ignore the form and its children. Use this feature to save a configuration that you are testing. Inactive forms are invisible to callers. When a node is inactive, it appears grayed out in the tree view.

Default Action check box

At any given "level" in the tree structure, one node can be marked as the default action. The operation defined by the [default node](#) is performed if the caller does not press a key within the timeout period specified by that menu. The icon for default forms has a green border in the tree structure. Any node below a menu or schedule can be marked as the [default action](#), by checking the form's default action check box.

Enable IVR Reporting

This option determines whether or not reporting data will be collected when control passes through this node. Several IVR Reports summarize this information. IVR Reporting is *disabled* by default. Enable it to capture the date, time and duration of time that the call remained in the node and its children. This option is hidden when Attendant is connected to a server that does not have reporting installed. For more information about this feature, see [IVR Reporting Option](#).

Add entry to the Interaction Log

When this option is enabled, information about this node is appended to the call's Interaction Log when the call enters this node. This helps track the path that a call took through Attendant. The Interaction Log is maintained for reporting purposes. See [View the Interaction Log](#) for details.

Configure Speech Recognition... button

Select this button to configure words or phrases that can be associated with menu options. Callers can verbally indicate the options they want in the IVR instead of pressing a digit on the phone. You can enter multiple words and phrases for each menu item, just as callers may phrase the same request in different ways. For example, "transfer funds" or "funds transfer". See [Add Speech Recognition keywords or phrases to Inbound Call Operations](#).

Transfer the call to this menu frame

Transfer call combo box

Select any [menu](#) defined for the current server to transfer the call to.

Related Topics

- [Play a Menu](#)



Transfer to a Workgroup or Stationgroup

This node is sometimes called "Workgroup Transfer", since it transfers a call to a workgroup queue or to a station group queue. The destination workgroup is not caller-selectable at runtime.

The station group list box is sometimes used to set up a night transfer, which sends an unanswered call to a sequential series of station phones. You have the option to record or select an audio prompt that will be played before the call is transferred to the workgroup or station queue.

Node Characteristics frame

Options in this frame name the node, assign the digit used to select it, and establish whether or not it is active, used by default, logged, or tracked for reporting purposes.

Name field

The label you enter here becomes the name of the node in the tree structure.

Digit list box

Use this list to select the key that callers press to enter a caller data entry operation. When you assign a digit, the list displays only available digits—those that are not already in use at this level of the tree. If no digit is assigned, callers cannot invoke the operation directly. It is possible to create menu options that are invoked by a routing process, rather than by a user selection. For details, see [invoke a menu operation automatically](#).

Active check box

By default, forms are "on", or "active", which means that Interaction Attendant will process them. If you uncheck a form's Active check box, the name of the node turns gray in the tree to indicate that the form is inactive. Interaction Attendant and its [handlers](#) will thereafter ignore the form and its children. Use this feature to save a configuration that you are testing. Inactive forms are invisible to callers. When a node is inactive, it appears grayed out in the tree view.

Default Action check box

At any given "level" in the tree structure, one node can be marked as the default action. The operation defined by the [default node](#) is performed if the caller does not press a key within the timeout period specified by that menu. The icon for default forms has a green border in the tree structure. Any node below a menu or schedule can be marked as the [default action](#), by checking the form's default action check box.

Enable IVR Reporting

This option determines whether or not reporting data will be collected when control passes through this node. Several IVR Reports summarize this information. IVR Reporting is *disabled* by default. Enable it to capture the date, time and duration of time that the call remained in the node and its children. This option is hidden when Attendant is connected to a server that does not have reporting installed. For more information about this feature, see [IVR Reporting Option](#).

Add entry to the Interaction Log

When this option is enabled, information about this node is appended to the call's Interaction Log when the call enters this node. This helps track the path that a call took through Attendant. The Interaction Log is maintained for reporting purposes. See [View the Interaction Log](#) for details.

Configure Speech Recognition... button

Select this button to configure words or phrases that can be associated with menu options. Callers can verbally indicate the options they want in the IVR instead of pressing a digit on the phone. You can enter multiple words and phrases for each menu item, just as callers may phrase the same request in different ways. For example, "transfer funds" or "funds transfer". See [Add Speech Recognition keywords or phrases to Inbound Call Operations](#).

Workgroup / Station Group / Attribute radio buttons

These options identify the workgroup or station group queue to which the call is transferred.

The screenshot shows a configuration panel with three radio buttons and two dropdown menus. The first radio button, labeled 'Workgroup', is selected. Below it is a dropdown menu. The second radio button, labeled 'Station Group:', is unselected. Below it is a dropdown menu with a red 'X' icon and the text 'No station groups have been defined.'. The third radio button, labeled 'Workgroup specified by interaction attribute: 'Eic_AttDynamicWorkgroupName'', is unselected.

Workgroup radio button

This radio button enables the workgroup drop down list.

Workgroup drop down list

This drop down list allows you to select the name of any workgroup queue that is defined for the server. The interaction will be transferred to the group you select.

Station Group radio button

This radio button enables the station group drop down list.

Station Group drop down list

This list box allows you to set up a night transfer, by selecting the name of a station group. A night transfer sends an unanswered call to a sequential series of station phones, called a station group. A station group is a set of station phones (defined in Interaction Administrator) that can be called when no one is logged in. A night transfer works like an ACD workgroup transfer, except that no one needs to be logged in to ring the station phone. Workgroup transfers, on the other hand, require someone to be logged in at the station.

Consider, for example, the needs of a security guard who must leave his desk to patrol a building. If no one answers a call to the guard desk, Attendant can transfer the call to phones in a station group, so that the guard can receive calls from different locations while on patrol.

Workgroup specified by interaction attribute radio button

This option allows you to select a specific workgroup by the workgroup ID contained in the interaction attribute 'Eic_AttDynamicWorkgroupName' and defined for the server. This is particularly helpful in environments which contain a large number of workgroups, thereby making it cumbersome to select the appropriate workgroup.

For example, you can organize workgroups according to area of expertise, such as web service calls, customer handler calls, etc., and assign names to the workgroups that help identify the specific skill. Then, you can place the workgroup name in the interaction attribute 'Eic_AttDynamicWorkgroupName' and use that attribute for a workgroup transfer operation.

Audio to play when the caller enters the workgroup

The screenshot shows a frame titled 'Audio to play when the caller enters the workgroup'. It contains a 'Name' dropdown menu with '<None>' selected. To the right of the dropdown is a 'Preview:' section with play, stop, and volume control buttons. Below the dropdown are three buttons: 'Browse...', 'Record...' (with a dropdown arrow), and 'Details...'.

This frame contains embedded audio controls that manage the voice prompt that plays when the caller enters the workgroup. See [Manage Voice Prompts](#).

Escaping the Workgroup Queue (ACD Only) frame

The options in this frame are enabled when an ACD workgroup is selected. They define a key that allows the caller to exit the node immediately. Control is passed to the action defined in the Actions When Finished frame.

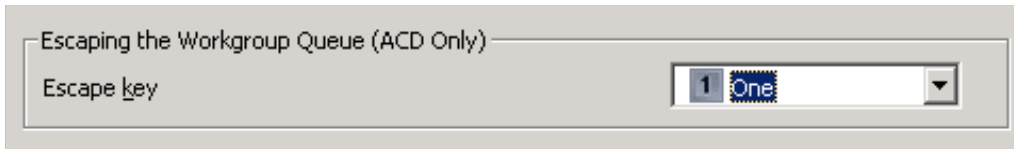

Escape Key

Defines a keystroke that allows the caller to exit the node immediately. The pound (#) or star key (*) is commonly used for this purpose. However, you can assign any available digit.

Actions When Finished frame

These options set flow of control that occurs when the user escapes from the Workgroup Queue.

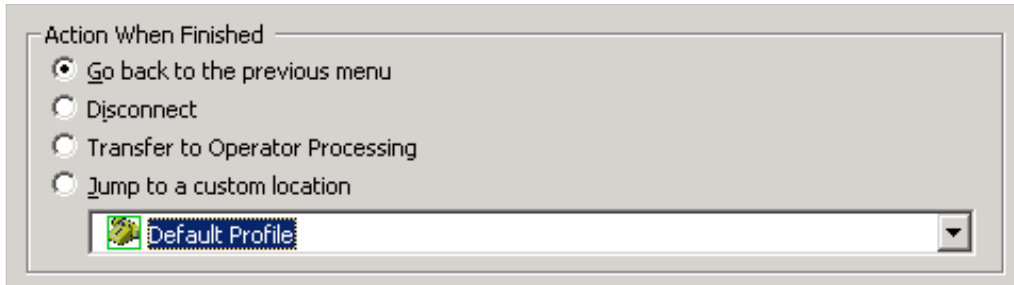

Go back to the previous menu radio button

The *Go back to the previous menu* option sets up a simple loop that "reruns" the parent menu from the top. It returns control to the parent menu from which the message was played.

Disconnect

Terminates the call.

Transfer to Operator Processing

Transfers the call for evaluation by operator profiles defined for this server.

Jump to a custom location radio button

Use this option to jump to any [profile](#), [schedule](#), [menu](#), or [operation](#) that is defined for the current server.

Advanced Workgroup Settings button

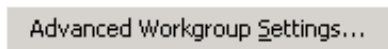

This button opens the [Advanced Workgroup Properties](#) dialog, so that you can set call priority, needed agent skills, the length of time that the call should remain in the queue before timing out, and processing to perform when the call times out. This button is disabled for operator profiles.

This button is enabled for custom workgroups; however, the settings must be implemented manually in handlers.

Related Topics

- [Advanced Workgroup Properties Dialog](#)



Transfer to an Agent

Agent Transfer sends a call to a specific [user queue](#) or [station queue](#). This operation is commonly used to create a menu option that allows the caller to speak to an operator.

To transfer calls to a workgroup, use [Group Transfer](#) instead of *Transfer to an Agent*.

Node Characteristics frame

Options in this frame name the node, assign the digit used to select it, and establish whether or not it is active, used by default, logged, or tracked for reporting purposes.

Name field

The label you enter here becomes the name of the node in the tree structure.

Digit list box

Use this list to select the key that callers press to enter a caller data entry operation. When you assign a digit, the list displays only available digits—those that are not already in use at this level of the tree. If no digit is assigned, callers cannot invoke the operation directly. It is possible to create menu options that are invoked by a routing process, rather than by a user selection. For details, see [invoke a menu operation automatically](#).

Active check box

By default, forms are "on", or "active", which means that Interaction Attendant will process them. If you uncheck a form's Active check box, the name of the node turns gray in the tree to indicate that the form is inactive. Interaction Attendant and its [handlers](#) will thereafter ignore the form and its children. Use this feature to save a configuration that you are testing. Inactive forms are invisible to callers. When a node is inactive, it appears grayed out in the tree view.

Default Action check box

At any given "level" in the tree structure, one node can be marked as the default action. The operation defined by the [default node](#) is performed if the caller does not press a key within the timeout period specified by that menu. The icon for default forms has a green border in the tree structure. Any node below a menu or schedule can be marked as the [default action](#), by checking the form's default action check box.

Enable IVR Reporting

This option determines whether or not reporting data will be collected when control passes through this node. Several IVR Reports summarize this information. IVR Reporting is *disabled* by default. Enable it to capture the date, time and duration of time that the call remained in the node and its children. This option is hidden when Attendant is connected to a server that does not have reporting installed. For more information about this feature, see [IVR Reporting Option](#).

Add entry to the Interaction Log

When this option is enabled, information about this node is appended to the call's Interaction Log when the call enters this node. This helps track the path that a call took through Attendant. The Interaction Log is maintained for reporting purposes. See [View the Interaction Log](#) for details.

Configure Speech Recognition... button

Select this button to configure words or phrases that can be associated with menu options. Callers can verbally indicate the options they want in the IVR instead of pressing a digit on the phone. You can enter multiple words and phrases for each menu item, just as callers may phrase the same request in different ways. For example, "transfer funds" or "funds transfer". See [Add Speech Recognition keywords or phrases to Inbound Call Operations](#).

Transfer To frame

The options in this frame determine whether the call is transferred to a user or station queue. In general, you should specify a user queue when you need to route calls to a specific person, you should specify a station queue when you need to route calls to a specific telephone handset, and you should select the 'Eic_AttDynamicAgentName' interaction attribute when the user or station has been defined within the interaction attribute.

Note: The 'Eic_AttDynamicAgentName' interaction attribute is helpful for environments that contain a large number of users or stations and allows you to designate a single user or station to the attribute, thereby alleviating the task of searching through the queue lists. See [Set Attribute](#) for details.

Transfer To

User Queue

Station Queue

Agent specified by interaction attribute:
'Eic_AttDynamicAgentName'

User Queue radio button

This radio button enables the User Queue drop down list.

User Queue drop down list

This drop down list contains the names of [user queues](#) defined for the current server. The queue you select becomes the destination for the call.

Station Queue radio button

This radio button enables the Station Queue drop down list.

Station Queue drop down list

This drop down list contains the names of [station queues](#) defined for the current server. The queue you select becomes the destination for the call.

Agent specified by interaction attribute: radio button

This radio button specifies the transfer recipient as defined in the 'Eic_AttDynamicAgentName' interaction attribute. The user defined in this interaction attribute becomes the destination for the call.

Park Interaction check box

Select this check box to allow interactions to be parked on another person's extension for the agent to receive when he or she has an available status.

Park Interaction

Transfer to an External Number

This operation transfers a calls to a telephone number outside of your organization. For example, you might use this option to route calls to an after-hours call center, or to transfer calls that come in "after hours" schedules to a different office. The menu designer presets the destination telephone number. The caller has no control over the destination.

This node does not offer additional error handling options. If the transfer fails, control is passed to the Schedule's error handler.

Node Characteristics Frame

Options in this frame name the node, assign the digit used to select it, and establish whether or not it is active, used by default, logged, or tracked for reporting purposes.

Name field

The label you enter here becomes the name of the node in the tree structure.

Digit list box

Use this list to select the key that callers press to enter a caller data entry operation. When you assign a digit, the list displays only available digits—those that are not already in use at this level of the tree. If no digit is assigned, callers cannot invoke the operation directly. It is possible to create menu options that are invoked by a routing process, rather than by a user selection. For details, see [invoke a menu operation automatically](#).

Active check box

By default, forms are "on", or "active", which means that Interaction Attendant will process them. If you uncheck a form's Active check box, the name of the node turns gray in the tree to indicate that the form is inactive. Interaction Attendant and its [handlers](#) will thereafter ignore the form and its children. Use this feature to save a configuration that you are testing. Inactive forms are invisible to callers. When a node is inactive, it appears grayed out in the tree view.

Default Action check box

At any given "level" in the tree structure, one node can be marked as the default action. The operation defined by the [default node](#) is performed if the caller does not press a key within the timeout period specified by that menu. The icon for default forms has a green border in the tree structure. Any node below a menu or schedule can be marked as the [default action](#), by checking the form's default action check box.

Enable IVR Reporting

This option determines whether or not reporting data will be collected when control passes through this node. Several IVR Reports summarize this information. IVR Reporting is *disabled* by default. Enable it to capture the date, time and duration of time that the call remained in the node and its children. This option is hidden when Attendant is connected to a server that does not have reporting installed. For more information about this feature, see [IVR Reporting Option](#).

Add entry to the Interaction Log

When this option is enabled, information about this node is appended to the call's Interaction Log when the call enters this node. This helps track the path that a call took through Attendant. The Interaction Log is maintained for reporting purposes. See [View the Interaction Log](#) for details.

Configure Speech Recognition... button

Select this button to configure words or phrases that can be associated with menu options. Callers can verbally indicate the options they want in the IVR instead of pressing a digit on the phone. You can enter multiple words and phrases for each menu item, just as callers may phrase the same request in different ways. For example, "transfer funds" or "funds transfer". See [Add Speech Recognition keywords or phrases to Inbound Call Operations](#).

Call Transfer options

Transfer the call to this number

Enter a destination telephone number in this field. It accepts string data, so you can type anything you like (numbers, letters, dashes, parenthesis). In addition to telephone numbers, you can enter:

- A SIP address, such as SIP:John.Doe@company.com.
- A word-based phone number (1-800-RENT-NOW)
- A call attribute in the form \$(ATTR_NAME) replacing ATTR_NAME with the name of any call attribute. This allows the parameter to be populated with a call attribute set earlier in the Attendant flow.
- Invalid data, since no error checking is performed to test the validity of your input.

Transfer the call to the number specified by interaction attribute...

Select this radio button to direct the call to the destination number specified in the 'Eic_AttDynamicExternalNumber' interaction attribute. See [Set Attribute](#) for details on how to modify an interaction attribute.

Release call on transfer check box

This option determines whether or not the call is released (putback) after it is transferred. By default, the call is not released. There are specific limits on the use of this feature. If a call is being recorded or monitored, it can not be removed from the xIC system using a putback. Recording or monitoring operations take precedence over the request for a PutBack, and a normal "tromboning" operation is performed instead. When a putback is performed, the call is transferred to a non-IC destination using one trunk instead of two.

Transfer to Voicemail

This operation transfers a call to the voice mailbox of the user or workgroup queue you specify. It prompts a caller that he or she is being transferred to the voice mail account of the specified user or workgroup queue.

The caller can then leave a message for that user or workgroup queue. If the caller is still connected after leaving a message, he or she is returned to the menu from which Voice Mail Transfer was called.

Node Characteristics frame

Options in this frame name the node, assign the digit used to select it, and establish whether or not it is active, used by default, logged, or tracked for reporting purposes.

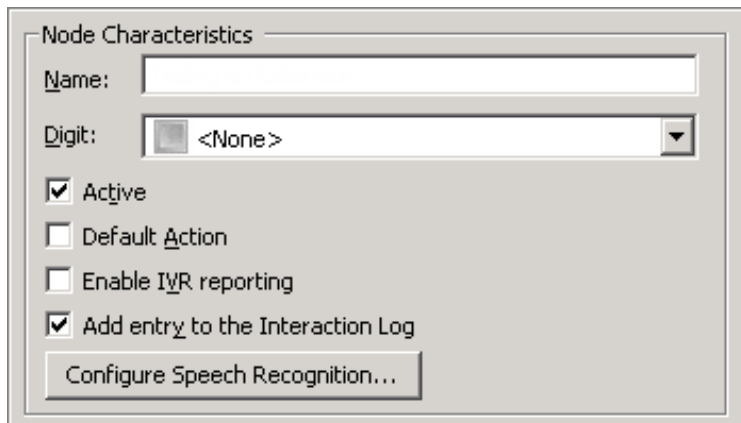

The screenshot shows a dialog box titled "Node Characteristics". It has the following elements:

- Name:** A text input field.
- Digit:** A dropdown menu currently showing "<None>".
- Active:** A checked checkbox.
- Default Action:** An unchecked checkbox.
- Enable IVR reporting:** An unchecked checkbox.
- Add entry to the Interaction Log:** A checked checkbox.
- Configure Speech Recognition...:** A button at the bottom.

Name field

The label you enter here becomes the name of the node in the tree structure.

Digit list box

Use this list to select the key that callers press to enter a caller data entry operation. When you assign a digit, the list displays only available digits—those that are not already in use at this level of the tree. If no digit is assigned, callers cannot invoke the operation directly. It is possible to create menu options that are invoked by a routing process, rather than by a user selection. For details, see [invoke a menu operation automatically](#).

Active check box

By default, forms are "on", or "active", which means that Interaction Attendant will process them. If you uncheck a form's Active check box, the name of the node turns gray in the tree to indicate that the form is inactive. Interaction Attendant and its [handlers](#) will thereafter ignore the form and its children. Use this feature to save a configuration that you are testing. Inactive forms are invisible to callers. When a node is inactive, it appears grayed out in the tree view.

Default Action check box

At any given "level" in the tree structure, one node can be marked as the default action. The operation defined by the [default node](#) is performed if the caller does not press a key within the timeout period specified by that menu. The icon for default forms has a green border in the tree structure. Any node below a menu or schedule can be marked as the [default action](#), by checking the form's default action check box.

Enable IVR Reporting

This option determines whether or not reporting data will be collected when control passes through this node. Several IVR Reports summarize this information. IVR Reporting is *disabled* by default. Enable it to capture the date, time and duration of time that the call remained in the node and its children. This option is hidden when Attendant is connected to a server that does not have reporting installed. For more information about this feature, see [IVR Reporting Option](#).

Add entry to the Interaction Log

When this option is enabled, information about this node is appended to the call's Interaction Log when the call enters this node. This helps track the path that a call took through Attendant. The Interaction Log is maintained for reporting purposes. See [View the Interaction Log](#) for details.

Configure Speech Recognition... button

Select this button to configure words or phrases that can be associated with menu options. Callers can verbally indicate the options they want in the IVR instead of pressing a digit on the phone. You can enter multiple words and phrases for each menu item, just as callers may phrase the same request in different ways. For example, "transfer funds" or "funds transfer". See [Add Speech Recognition keywords or phrases to Inbound Call Operations](#).

Transfer To frame

Selects the user or workgroup voice mail box that the call will be transferred to.

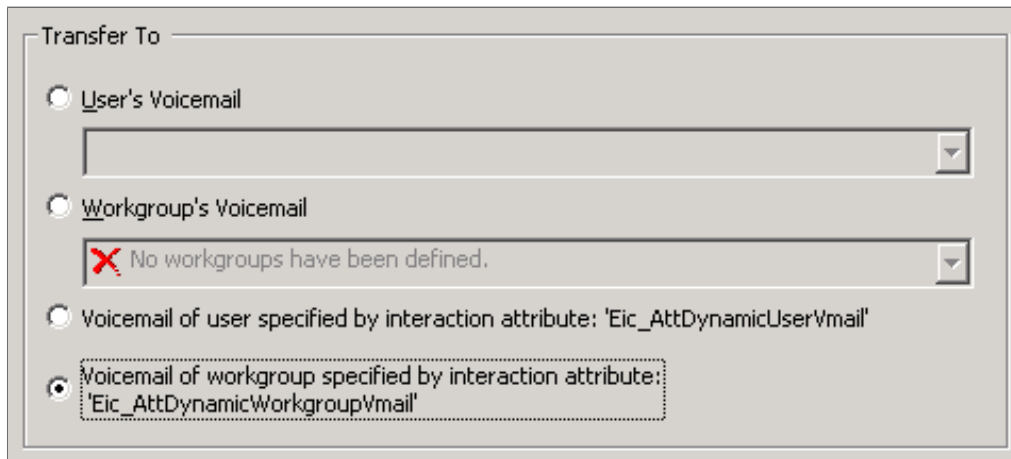

User's Voicemail

This list presents user voice mailboxes.

Workgroup's Voicemail

This list presents workgroup mailboxes.

Voicemail of user specified by interaction attribute: 'Eic_AttdynamicUserVmail'

This radio button specifies the user as defined in the 'Eic_AttDynamicUserVmail' interaction attribute. The voice mailbox of the user defined in this interaction attribute becomes the destination for the voicemail.

Voicemail of workgroup specified by interaction attribute: 'Eic_AttDynamicWorkgroupVmail'

This radio button specifies the workgroup voice mailbox as defined in the interaction attribute 'Eic_AttDynamicWorkgroupVmail' and defined for the server. This is particularly helpful in environments which contain a large number of workgroups, thereby making it cumbersome to select the appropriate workgroup voice mailbox. For example, you can organize workgroups according to area of expertise, such as web service calls, customer handler calls, etc., and assign names to the workgroups that help identify the specific skill. Then, you can place the workgroup name in the interaction attribute 'Eic_AttDynamicWorkgroupName' and use that attribute to transfer the voicemail to a specific workgroup.

Action When Finished frame

These options set the processing that occurs after the operation completes successfully, when flow of control leaves this node. You can return control to the previous menu, disconnect the call, transfer to an operator profile, or jump to any node or action that has been defined for the current server.

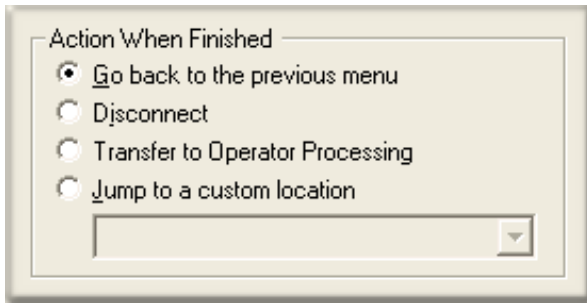

Go back to previous menu

This option returns control to the parent menu. This sets up a simple loop that "reruns" the menu from the top.

Disconnect

This option disconnects the call when the data entry operation is completed successfully.

Transfer to Operator Processing

Transfers the call for evaluation by operator profiles defined for this server.

Jump to a custom location

This option allows you to jump to any [profile](#), [schedule](#), [menu](#), or [operation](#) that is defined for the current server.



Transfer to an Attendant Profile

This node transfers the current call to a profile defined for this server. It is available from all configuration types (inbound, outbound, or operator) and provides the ability to transfer the call into a profile in either of the other two types. This is particularly useful when Operator processing needs to send the call to inbound call processing.

Node Characteristics frame

Options in this frame name the node, assign the digit used to select it, and establish whether or not it is active, used by default, logged, or tracked for reporting purposes.

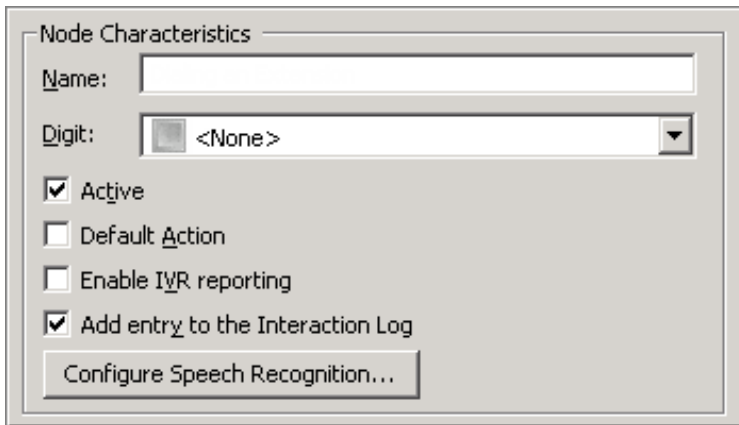

Name field

The label you enter here becomes the name of the node in the tree structure.

Digit combo box

This is the key that callers press to select a menu entry. When you assign a digit, the only available digits are those that are not already in use at this level of the tree. If no digit is assigned, callers cannot invoke the operation directly. It is possible to create menu options that are invoked by a routing process, rather than by a user selection. See [invoke a menu operation automatically](#).

Operator Target Handling

This node can be configured to handle a caller who presses 0 to exit to an Operator from voice mail. To do this, add a Transfer to Attendant Profile node, and set its digit to 0. Then configure the node to transfer to an Operator Profile. This allows for flexible after hours handling and workgroup handling of a department's operator needs.

Likewise, you might set the digit to * to configure "escape processing", wherein a caller presses * to exit from a menu to the operator.

Active check box

By default, forms are "on", or "active", which means that Interaction Attendant will process them. If you uncheck a form's Active check box, the name of the node turns gray in the tree to indicate that the form is inactive. Interaction Attendant and its [handlers](#) will thereafter ignore the form and its children. Use this feature to save a configuration that you are testing. Inactive forms are invisible to callers. When a node is inactive, it appears grayed out in the tree view.

Default Action check box

At any given "level" in the tree structure, one node can be marked as the default action. The operation defined by the [default node](#) is performed if the caller does not press a key within the timeout period specified by that menu. The icon for default forms has a green border in the tree structure. Any node below a menu or schedule can be marked as the [default action](#), by checking the form's default action check box.

Enable IVR Reporting

This option determines whether or not reporting data will be collected when control passes through this node. Several IVR Reports summarize this information. IVR Reporting is *disabled* by default. Enable it to capture the date, time and duration of time that the call remained in the node and its children. This option is hidden when Attendant is connected to a server that does not have reporting installed. For more information about this feature, see [IVR Reporting Option](#).

Add entry to the Interaction Log

When this option is enabled, information about this node is appended to the call's Interaction Log when the call enters this node. This helps track the path that a call took through Attendant. The Interaction Log is maintained for reporting purposes. See [View the Interaction Log](#) for details.

Configure Speech Recognition... button

Select this button to configure words or phrases that can be associated with menu options. Callers can verbally indicate the options they want in the IVR instead of pressing a digit on the phone. You can enter multiple words and phrases for each menu item, just as callers may phrase the same request in different ways. For example, "transfer funds" or "funds transfer". See [Add Speech Recognition keywords or phrases to Inbound Call Operations](#).

Transfer to profile frame

These options determine which inbound, outbound, or operator profile the call will be transferred to. The profile you select must be defined for this server.

The Inbound Profile that matches this call

Transfers the call to the inbound profile that best matches its call characteristics.

The custom Inbound Profile

Transfers the call to a specific inbound profile. The profile is given control over the call, regardless of whether or not the profile matches the its call characteristics.

The Outbound Profile that matches this call

Transfers the call to the outbound profile that best matches its call characteristics.

The custom Outbound Profile

Transfers the call to a specific outbound profile. The profile is given control over the call, regardless of whether or not the profile matches the its call characteristics.

Related Topics

- [Profiles](#)
- [Call Flows](#)

Database Operations

Database operations query a database and can play back a field to the caller using text-to-speech. These nodes can also insert a new row, or update a database field.

[Database Insert](#)

Inserts a row (record) into a database table.

[Database Query](#)

Returns one row (record) from your database, and plays back a single field to the caller using text-to-speech.

[Database Update](#)

Updates a single field in one database record.

DB Insert

This menu operation inserts a new row (record) into a database table. This is frequently used to log customer activity. To insert a new record, you must know the name of the data source, table, and column that data will be stored in, and which fields in the database are required when adding a new record. You can insert information based upon:

- String, numeric, or Boolean values
- A Call Attribute (ANI, DNIS, Caller ID, Interaction ID Key, Line Name)
- User input captured using a Caller Data Entry form
- The result of a database query
- The current date or current time
- Any specified date or time
- Flow of control options on this form determine what happens after a record is inserted.

IMPORTANT—DB Insert in Attendant will not insert numeric values unless the Numeric data type of a field is defined in the SQL database to declare a nonzero value for the Scale parameter.

The DB Insert operation in Attendant won't insert numeric values into a table unless the SQL data type is Real. When using SQL, the Real data type is required for inserting Numeric values from handlers. If you use the Numeric data type, numbers will be truncated or rounded to Integer values. Likewise, the behavior for different "decimal number" data types is inconsistent from one database to another. To avoid these problems, you should pay attention to the database configuration of numeric data types, and explicitly specify the number of digits to the right of the decimal.

When you create a column in an SQL table with a Numeric data type, there is a number value next to the data type field called "Length." This is the total number of digits allowed to the left of the decimal point. To avoid problems, you also must set the "Scale" parameter to something other than the default, 0, to allow for digits to the right of the decimal point.

If the Scale setting for Numeric fields is set to zero in the database, the DB Insert operation fails when it tries to insert numeric values. Specifically, step 73 of the InAttInsert handler (DB Put Data List toolstep) takes the failure path since the AttrvalueList field will have a null value. To resolve this problem, define the Scale of numeric fields in the SQL database to be > 0.

Node Characteristics frame

Options in this frame name the node, assign the digit used to select it, and establish whether or not it is active, used by default, logged, or tracked for reporting purposes.

Name field

The label you enter here becomes the name of the node in the tree structure.

Digit list box

Use this list to select the key that callers press to enter a caller data entry operation. When you assign a digit, the list displays only available digits—those that are not already in use at this level of the tree. If no digit is assigned, callers cannot invoke the operation directly. It is possible to create menu options that are invoked by a routing process, rather than by a user selection. For details, see [invoke a menu operation automatically](#).

Active check box

By default, forms are "on", or "active", which means that Interaction Attendant will process them. If you uncheck a form's Active check box, the name of the node turns gray in the tree to indicate that the form is inactive. Interaction Attendant and its [handlers](#) will thereafter ignore the form and its children. Use this feature to save a configuration that you are testing. Inactive forms are invisible to callers. When a node is inactive, it appears grayed out in the tree view.

Default Action check box

At any given "level" in the tree structure, one node can be marked as the default action. The operation defined by the [default node](#) is performed if the caller does not press a key within the timeout period specified by that menu. The icon for default forms has a green border in the tree structure. Any node below a menu or schedule can be marked as the [default action](#), by checking the form's default action check box.

Enable IVR Reporting

This option determines whether or not reporting data will be collected when control passes through this node. Several IVR Reports summarize this information. IVR Reporting is *disabled* by default. Enable it to capture the date, time and duration of time that the call remained in the node and its children. This option is hidden when Attendant is connected to a server that does not have reporting installed. For more information about this feature, see [IVR Reporting Option](#).

Add entry to the Interaction Log

When this option is enabled, information about this node is appended to the call's Interaction Log when the call enters this node. This helps track the path that a call took through Attendant. The Interaction Log is maintained for reporting purposes. See [View the Interaction Log](#) for details.

Configure Speech Recognition... button

Select this button to configure words or phrases that can be associated with menu options. Callers can verbally indicate the options they want in the IVR instead of pressing a digit on the phone. You can enter multiple words and phrases for each menu item, just as callers may phrase the same request in different ways. For example, "transfer funds" or "funds transfer". See [Add Speech Recognition keywords or phrases to Inbound Call Operations](#).

DB Information frame

Options in this frame identify the data source and table that the database operation will apply to.

IC Data Source

Select the name of a database as it is defined in Interaction Administrator. See [IC Data Source Configuration](#) in the Interaction

Administrator help to find out data sources are defined for CIC and its subsystems. Typically, this list contains I3Text White Pages, CIC Contacts, CIC Report Logging, CIC Report Logs, Tracker, and custom databases defined by your organization.

Table Name

Records will be inserted into the table whose name you enter here. If you do not know the names of tables in your database, contact your CIC Administrator.

Columns to Insert frame

This mini-table manages entries made to identify fields and data to insert into them. The Add, Modify, and Remove buttons work together to define fields that will be added as a new record. You need to know which fields are required when adding a record to your database. Those fields must be defined here, along with any additional data items that you wish to add as part of the record. When you define a field, it appears in the list.

Column	Type	Value
Call_Info	ATTR	Caller ID

Each column must already be defined in the database. Insert adds data to existing columns in a database. It does not define new columns. If the specified column does not exist, no data is inserted.

Add button

Add opens the [Column Information](#) dialog, to define data that you want to insert, and the column (field) it will be inserted into.

Modify button

Modify populates the same dialog with the selected entry.

Remove button

Remove deletes the selected entry from the list. This does not remove the field from your database. Instead, it removes the option to populate a data field when a new record is added.

Action When Finished frame

These options set the processing that occurs after the operation completes successfully, when flow of control leaves the node. You can return control to the previous menu, disconnect the call, transfer to an operator profile, or jump to any node or action that has been defined for the current server.

Action When Finished

- Go back to the previous menu
- Disconnect
- Transfer to Operator Processing
- Jump to a custom location

Go back to previous menu

This option returns control to the parent menu. This sets up a simple loop that "reruns" the menu from the top.

Disconnect

This option disconnects the call when the database operation completes successfully.

Transfer to Operator Processing

Transfers the call for evaluation by operator profiles defined for this server.

Jump to a custom location

This option allows you to jump to any [profile](#), [schedule](#), [menu](#), or [operation](#) that is defined for the current server.

Database Query is the database operation you are most likely to use. It allows you to query a particular value from a CIC data source. For example, a caller might select this operation from a menu to look up his account balance from your database.

The information returned by the query can be read back to the caller using text-to-speech technology. Data can be attached to a call attribute and used for DDE operations, such as screen pops.

You can control the type of processing that occurs if a query does not return any data. A null result may not indicate an error condition. Control can be passed to logic that provides "no record found" processing. Alternately, you can treat null results as "real errors" that require standard error handling.

Database Query returns one column (field) from your database, and reads it back to the caller. You cannot play back an entire row of data.

To Define a Query

To create a new query, perform these steps:

Complete the Node Characteristics section to define general characteristics, such as the digit that callers press to run the query.

Identify the *data source* and *table name*.

Press the *Record Selection* button to define record selection criteria.

Press the *Results Processing* button to specify how results should be processed if a query result is returned (or not returned).

Node Characteristics frame

Options in this frame name the node, assign the digit used to select it, and establish whether or not it is active, used by default, logged, or tracked for reporting purposes.

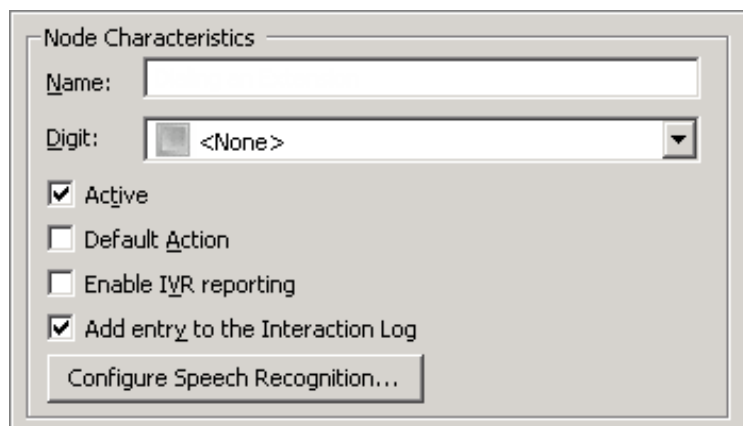

Name field

The label you enter here becomes the name of the node in the tree structure.

Digit list box

Use this list to select the key that callers press to enter a caller data entry operation. When you assign a digit, the list displays only available digits—those that are not already in use at this level of the tree. If no digit is assigned, callers cannot invoke the operation directly. It is possible to create menu options that are invoked by a routing process, rather than by a user selection. For details, see [invoke a menu operation automatically](#).

Active check box

By default, forms are "on", or "active", which means that Interaction Attendant will process them. If you uncheck a form's Active check box, the name of the node turns gray in the tree to indicate that the form is inactive. Interaction Attendant and its [handlers](#) will thereafter ignore the form and its children. Use this feature to save a configuration that you are testing. Inactive forms are invisible to callers. When a node is inactive, it appears grayed out in the tree view.

Default Action check box

At any given "level" in the tree structure, one node can be marked as the default action. The operation defined by the [default node](#) is performed if the caller does not press a key within the timeout period specified by that menu. The icon for default forms has a green border in the tree structure. Any node below a menu or schedule can be marked as the [default action](#), by checking the form's default action check box.

Enable IVR Reporting

This option determines whether or not reporting data will be collected when control passes through this node. Several IVR Reports summarize this information. IVR Reporting is *disabled* by default. Enable it to capture the date, time and duration of time that the

call remained in the node and its children. This option is hidden when Attendant is connected to a server that does not have reporting installed. For more information about this feature, see [IVR Reporting Option](#).

Add entry to the Interaction Log

When this option is enabled, information about this node is appended to the call's Interaction Log when the call enters this node. This helps track the path that a call took through Attendant. The Interaction Log is maintained for reporting purposes. See [View the Interaction Log](#) for details.

Configure Speech Recognition... button

Select this button to configure words or phrases that can be associated with menu options. Callers can verbally indicate the options they want in the IVR instead of pressing a digit on the phone. You can enter multiple words and phrases for each menu item, just as callers may phrase the same request in different ways. For example, "transfer funds" or "funds transfer". See [Add Speech Recognition keywords or phrases to Inbound Call Operations](#).

DB Information frame

Options in this frame identify the data source and table that the database operation will apply to.

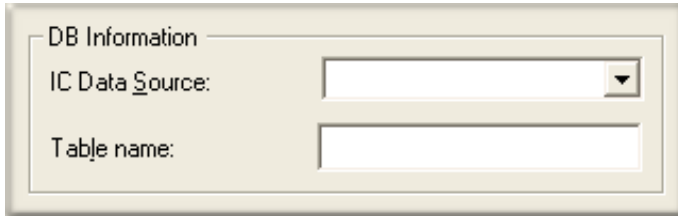

IC Data Source

Select the name of a database as it is defined in Interaction Administrator. See [IC Data Source Configuration](#) in the Interaction Administrator help to find out data sources are defined for CIC and its subsystems. Typically, this list contains I3Text White Pages, CIC Contacts, CIC Report Logging, CIC Report Logs, Tracker, and custom databases defined by your organization.

Table Name

Records will be selected from the table whose name you enter here. If you do not know the names of tables in your database, contact your Database Administrator.

Record Selection button

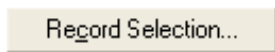

This button opens the [DB Record Selection Dialog](#) so that you can define criteria that Attendant will use to select a database record.

Query Information frame

This section identifies the name of the column that will be retrieved from the record.



Column to Retrieve

Enter the name of the column that will be retrieved by the database query. If you do not know its exact name, contact your Database Administrator. Note that the column name is case-sensitive.

Results Processing button

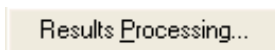

This button opens the [Results Processing](#) dialog, so that you can define actions to take when results are returned, and actions to take if no results are returned. This dialog also determines whether the query result is read back to the caller.

Action When Finished frame

These options set the processing that occurs after the operation completes successfully, when flow of control leaves the node. You can return control to the previous menu, disconnect the call, transfer to an operator profile, or jump to any node or action that has been defined for the current server.

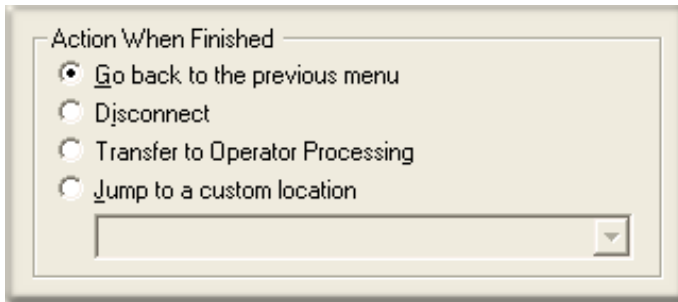

Go back to previous menu

This option returns control to the parent menu. This sets up a simple loop that "reruns" the menu from the top.

Disconnect

This option disconnects the call when the database operation completes successfully.

Transfer to Operator Processing

Transfers the call for evaluation by operator profiles defined for this server.

Jump to a custom location

This option allows you to jump to any [profile](#), [schedule](#), [menu](#), or [operation](#) that is defined for the current server.

DB Update

This operation updates a single field in one database record. For example, you might create a menu that allows callers to update survey information in a database (1=agree, 2=disagree). Database Update is limited. It can't do more than replace the contents of a field. For instance, it cannot add, subtract, increment numeric values, or update a row.

To update a field in a database table, follow these simple steps:

Identify the *data source* and *table* name.

Perform Record Selection, by opening the [DB Record Selection](#) dialog to select a record to update.

Identify the *Update Action*, by opening the Update Column dialog to specify which column (field) will be updated and the data that will be assigned to the field.

Define flow-of-control actions that take place when this menu operation finishes.

Node Characteristics frame

Options in this frame name the node, assign the digit used to select it, and establish whether or not it is active, used by default, logged, or tracked for reporting purposes.

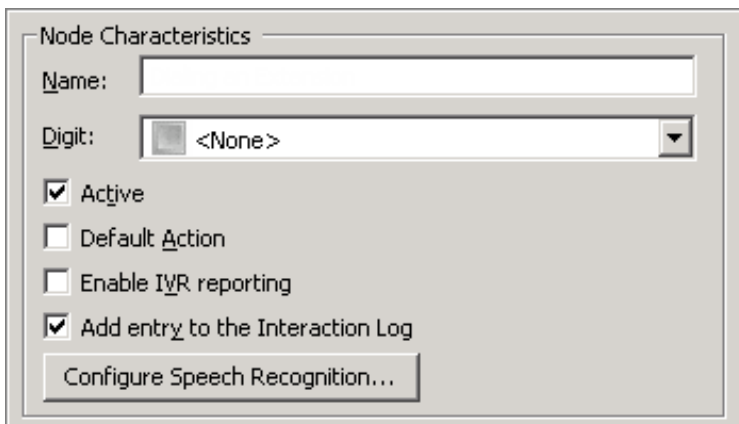

Name field

The label you enter here becomes the name of the node in the tree structure.

Digit list box

Use this list to select the key that callers press to enter a caller data entry operation. When you assign a digit, the list displays only available digits—those that are not already in use at this level of the tree. If no digit is assigned, callers cannot invoke the operation

directly. It is possible to create menu options that are invoked by a routing process, rather than by a user selection. For details, see [invoke a menu operation automatically](#).

Active check box

By default, forms are "on", or "active", which means that Interaction Attendant will process them. If you uncheck a form's Active check box, the name of the node turns gray in the tree to indicate that the form is inactive. Interaction Attendant and its [handlers](#) will thereafter ignore the form and its children. Use this feature to save a configuration that you are testing. Inactive forms are invisible to callers. When a node is inactive, it appears grayed out in the tree view.

Default Action check box

At any given "level" in the tree structure, one node can be marked as the default action. The operation defined by the [default node](#) is performed if the caller does not press a key within the timeout period specified by that menu. The icon for default forms has a green border in the tree structure. Any node below a menu or schedule can be marked as the [default action](#), by checking the form's default action check box.

Enable IVR Reporting

This option determines whether or not reporting data will be collected when control passes through this node. Several IVR Reports summarize this information. IVR Reporting is *disabled* by default. Enable it to capture the date, time and duration of time that the call remained in the node and its children. This option is hidden when Attendant is connected to a server that does not have reporting installed. For more information about this feature, see [IVR Reporting Option](#).

Add entry to the Interaction Log

When this option is enabled, information about this node is appended to the call's Interaction Log when the call enters this node. This helps track the path that a call took through Attendant. The Interaction Log is maintained for reporting purposes. See [View the Interaction Log](#) for details.

Configure Speech Recognition... button

Select this button to configure words or phrases that can be associated with menu options. Callers can verbally indicate the options they want in the IVR instead of pressing a digit on the phone. You can enter multiple words and phrases for each menu item, just as callers may phrase the same request in different ways. For example, "transfer funds" or "funds transfer". See [Add Speech Recognition keywords or phrases to Inbound Call Operations](#).

DB Information frame

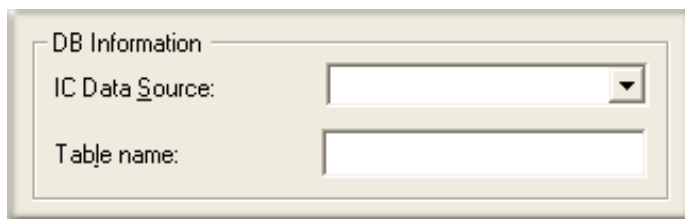

The image shows a graphical user interface element titled "DB Information". It contains two input fields: "IC Data Source" which is a dropdown menu, and "Table name" which is a text input field.

IC Data Source

Select the name of a database as it is defined in Interaction Administrator. See *IC Data Source Configuration* in the Interaction Administrator help to find out data sources are defined for CIC and its subsystems. Typically, this list contains I3Text White Pages, CIC Contacts, CIC Report Logging, CIC Report Logs, Tracker, and custom databases defined by your organization.

Table Name

Records will be updated in the table whose name you enter here. If you do not know the names of tables in your database, contact your Database Administrator.

Record Selection button

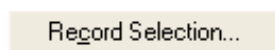

This button opens the [DB Record Selection](#) dialog, so that you can define criteria that Attendant will use to select a database record.

Update Action button

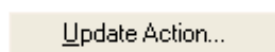

Opens the [Update Column](#) dialog so that you can specify which field that will be updated, and the content that will be assigned to the field.

Action When Finished frame

These options set the processing that occurs after the operation completes successfully, when flow of control leaves the node. You can return control to the previous menu, disconnect the call, transfer to an operator profile, or jump to any node or

action that has been defined for the current server.

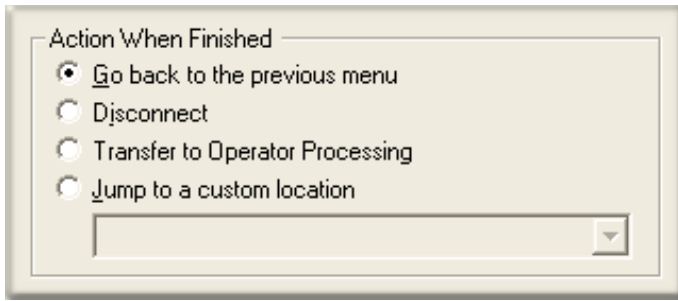

Action When Finished

- Go back to the previous menu
- Disconnect
- Transfer to Operator Processing
- Jump to a custom location

_____ ▾

Go back to previous menu

This option returns control to the parent menu. This sets up a simple loop that "reruns" the menu from the top.

Disconnect

This option disconnects the call when the database operation completes successfully.

Transfer to Operator Processing

Transfers the call for evaluation by operator profiles defined for this server.

Jump to a custom location

This option allows you to jump to any [profile](#), [schedule](#), [menu](#), or [operation](#) that is defined for the current server.

Queue Operations

Queue operations interact with callers who are waiting in queues.

Queue Operation	Description
Continue waiting in this queue	Allows a caller to elect to remain on hold in a queue.
Play a message to the Caller	Plays a message for a caller in a queue. This message indicates the caller's position in the queue, estimated wait time, or is any custom message that you have recorded.
Present a Menu to the Caller	Presents the caller with menu choices while he or she waits in the queue. A queue menu works like a standard menu, except that a limited set of operations can be attached to it.
Repeat a Sequence of Queue operations	Loops back to a previous node (of type queue) during the queue processing.
Transfer the call out of this queue	Transfers a call directly to a user, workgroup, or station queue.
Callback Request	Allows a caller to request a callback. ANI data about the call is examined at runtime to capture the caller's telephone number, and a new callback request object is placed on the workgroup queue specified in the form. The callback occurs when an agent picks up the callback from the queue. The caller does not have to wait on hold or possibly incur long distance charges while waiting to speak with an agent.

Queue operations are disabled until a **Group Transfer** node is configured to transfer the call to an ACD (or custom) workgroup. Queue Stay and Queue Transfer are disabled until a Queue Menu node is selected. The figure below illustrates these relationships:

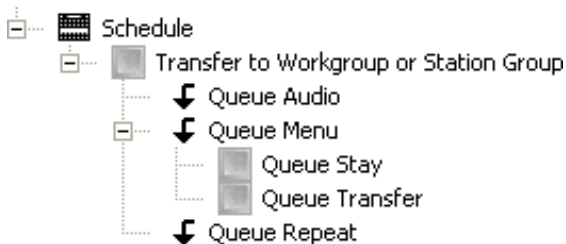

Add and Remove Skills from an In-Queue Call

You can modify skill requirements while a call is in-queue by adding the Queue Update Skills action as an in-queue action under a workgroup transfer. This action allows you to add or remove skills without transferring the call to a different queue.

Warning: Due to current ACD Server limitations, when you update skills in an in-queue call, Interaction Attendant temporarily removes the interaction from the workgroup queue when updating the ACD skills. The interaction is reprocessed when Attendant returns it to the queue, and resets any existing ACD statistics such as Queue Timeout and the interaction's position in queue.

To add or remove skills from an in-queue call:

1. From a workgroup transfer node, click the Queue Update Skills icon or select Add/Remove skills for the interaction from the Queue Operations menu. The Queue Update Skills form appears below the transfer action.

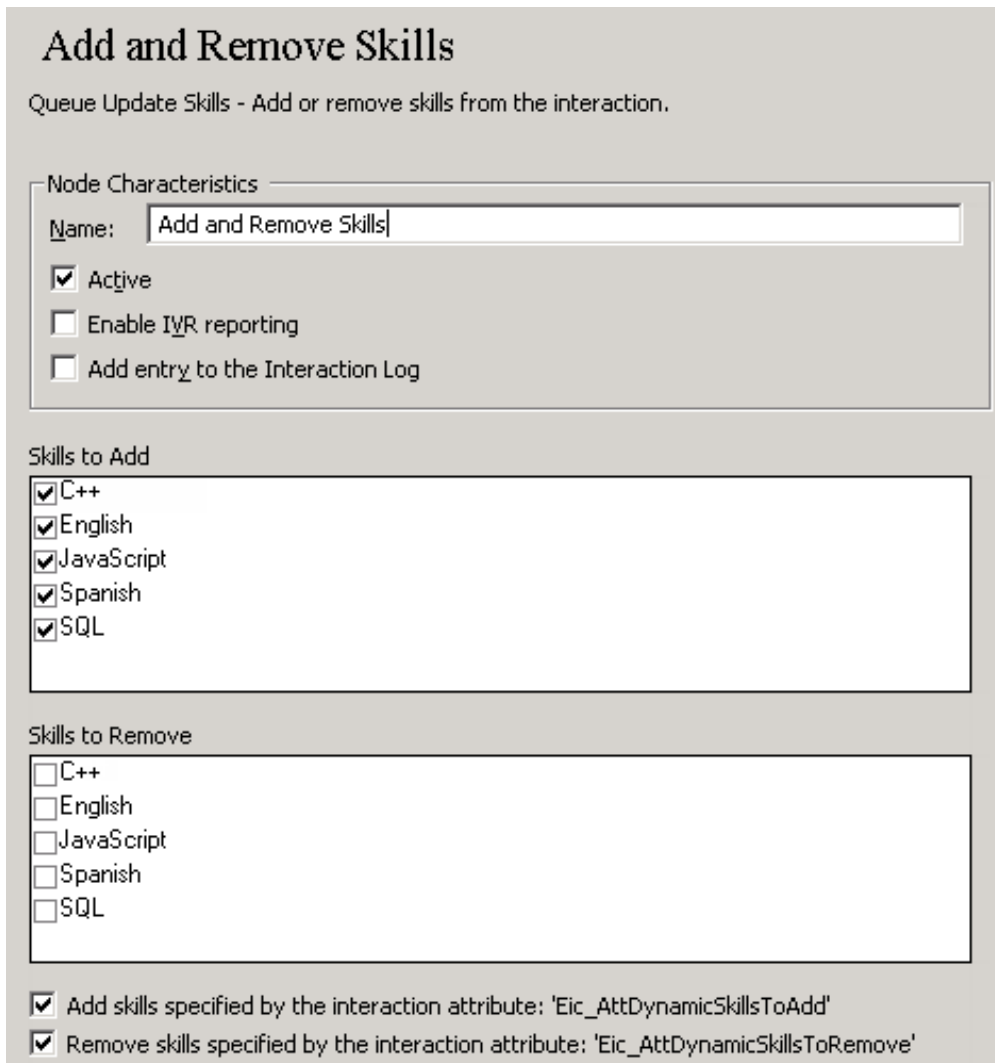

Add and Remove Skills

Queue Update Skills - Add or remove skills from the interaction.

Node Characteristics

Name:

Active

Enable IVR reporting

Add entry to the Interaction Log

Skills to Add

C++

English

JavaScript

Spanish

SQL

Skills to Remove

C++

English

JavaScript

Spanish

SQL

Add skills specified by the interaction attribute: 'Eic_AttDynamicSkillsToAdd'

Remove skills specified by the interaction attribute: 'Eic_AttDynamicSkillsToRemove'

2. In the Node Characteristics area, name the node, establish whether or not it is active, logged, or tracked for reporting purposes.
 - Name field. the label you enter here becomes the name of the node in the tree structure.
 - Active check box. By default, forms are "on", or "active", which means Interaction Attendant will process them. If you uncheck a form's Active check box, the name of the node turns gray in the tree to indicate that the form is inactive. Interaction Attendant and its [handlers](#) will therefore ignore the form and its children. Use this feature to save a configuration that you are testing. Inactive forms are not visible to callers. When a node is inactive, it appears grayed out in the tree view.
 - Default Action check box. At any given "level" in the tree structure, one node can be marked as the default action. The operation defined by the [default node](#) is performed if the caller does not press a key within the timeout period specified by that menu. The icon for default forms has a green border in the tree structure. Any node below a menu or schedule can be marked as the [default action](#) by checking the form's default action check box.
 - Enable IVR Reporting. This option determines whether or not reporting data will be collected when control passes through this node. Several IVR Reports summarize this information. IVR Reporting is disabled by default. Enable it to capture the date, time, and duration of time that the call remained in the node and its children. This option is hidden when Attendant is connected to a server that does not have reporting installed. For more information, see [IVR Reporting Option](#).
 - Add entry to the Interaction Log. When this option is enabled, tracking information about this node is appended to the call's Interaction Log when the call enters this node. This helps track the path that a call took through Attendant. The Interaction Log is maintained for reporting purposes. See [View the Interaction Log](#) for details.
3. To add a skill to the interaction, in the Skills to Add area click to place a check mark next to the skill you want to add to this interaction.
4. To remove a skill from the interaction, in the Skills to Remove area click to remove the check mark next to the skill you want to delete from the interaction.
5. To add skills from a list specified by the dynamic interaction attribute 'Eic_AttDynamicSkillsToAdd', place a check mark in the box next to this option.

6. To remove skills from a list specified by the dynamic interaction attribute 'Eic_AttDynamicSkillsToRemove', place a check mark in the box next to this option.

Ⓢ Continue waiting in this queue

This option allows a caller to elect to remain on hold in a queue. This operation is disabled until you create a [queue menu](#) below a [Group transfer](#). When you select the queue menu, you will be able to add this operation. This operation has no configurable options, except for general node characteristics. This operation is also called Queue Stay.

This operation must be the child of a Queue Menu node.

Node Characteristics frame

Options in this frame name the node, assign the digit used to select it, and establish whether or not it is active, used by default, logged, or tracked for reporting purposes.

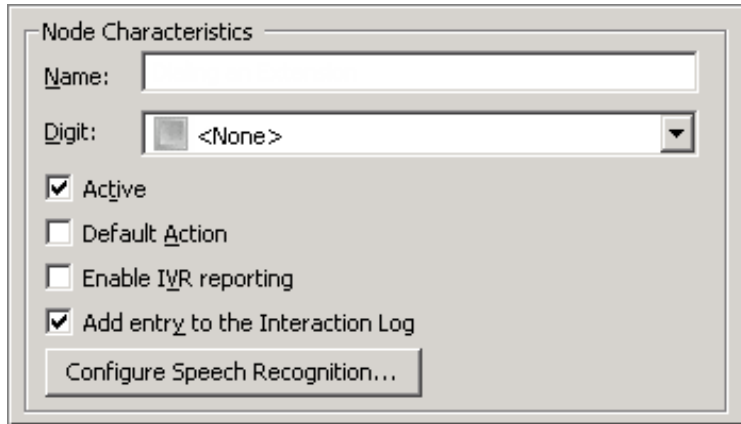

The screenshot shows a dialog box titled "Node Characteristics". It has a "Name:" text input field. Below it is a "Digit:" dropdown menu currently showing "<None>". There are four checkboxes: "Active" (checked), "Default Action" (unchecked), "Enable IVR reporting" (unchecked), and "Add entry to the Interaction Log" (checked). At the bottom is a button labeled "Configure Speech Recognition...".

Name field

The label you enter here becomes the name of the node in the tree structure.

Digit list box

Use this list to select the key that callers press to enter a caller data entry operation. When you assign a digit, the list displays only available digits—those that are not already in use at this level of the tree. If no digit is assigned, callers cannot invoke the operation directly. It is possible to create menu options that are invoked by a routing process, rather than by a user selection. For details, see [invoke a menu operation automatically](#).

Active check box

By default, forms are "on", or "active", which means that Interaction Attendant will process them. If you uncheck a form's Active check box, the name of the node turns gray in the tree to indicate that the form is inactive. Interaction Attendant and its [handlers](#) will thereafter ignore the form and its children. Use this feature to save a configuration that you are testing. Inactive forms are invisible to callers. When a node is inactive, it appears grayed out in the tree view.

Default Action check box

At any given "level" in the tree structure, one node can be marked as the default action. The operation defined by the [default node](#) is performed if the caller does not press a key within the timeout period specified by that menu. The icon for default forms has a green border in the tree structure. Any node below a menu or schedule can be marked as the [default action](#), by checking the form's default action check box.

Enable IVR Reporting

This option determines whether or not reporting data will be collected when control passes through this node. Several IVR Reports summarize this information. IVR Reporting is *disabled* by default. Enable it to capture the date, time and duration of time that the call remained in the node and its children. This option is hidden when Attendant is connected to a server that does not have reporting installed. For more information about this feature, see [IVR Reporting Option](#).

Add entry to the Interaction Log

When this option is enabled, information about this node is appended to the call's Interaction Log when the call enters this node. This helps track the path that a call took through Attendant. The Interaction Log is maintained for reporting purposes. See [View the Interaction Log](#) for details.

Configure Speech Recognition... button

Select this button to configure words or phrases that can be associated with menu options. Callers can verbally indicate the options they want in the IVR instead of pressing a digit on the phone. You can enter multiple words and phrases for each menu item, just as callers may phrase the same request in different ways. For example, "transfer funds" or "funds transfer". See [Add Speech Recognition keywords or phrases to Inbound Call Operations](#).



Play a Message to the caller

This operation plays a message to a caller who is waiting in a queue. This operation is disabled unless one of the other [queue operations](#) is selected in the tree view. This operation is also called *Queue Audio*.

Tip—Queue operations that require ACD workgroups (queue audio, queue menu, queue repeat) are disabled when a non-ACD workgroup queue is selected. These operations are automatically enabled in toolbars and menus when an ACD workgroup is selected in the node that the operation is attached to. In previous releases, it was possible to create queue nodes did not execute for sequential or group workgroups.

For example, one could have set a queue audio node to play a .wav file under a sequential or group ring group transfer node. When a call came into that queue, the caller heard the default hold music while any available agents are alerted. If the call was not answered, it was forwarded to the group's Voicemail. On a sequential workgroup, when there were no available agents, the call went directly to Voicemail and the queue audio was never played.

Queue Audio frame

Options in this frame name the node and establish whether or not it is active, logged, or tracked for reporting purposes. You cannot configure this node as a default action, since this operation is not invoked in response to a key press.

Name field

The label you enter here becomes the name of the node in the tree structure.

Active check box

By default, forms are "on", or "active", which means that Interaction Attendant will process them. If you uncheck a form's Active check box, the name of the node turns gray in the tree to indicate that the form is inactive. Interaction Attendant and its [handlers](#) will thereafter ignore the form and its children. Use this feature to save a configuration that you are testing. Inactive forms are invisible to callers. When a node is inactive, it appears grayed out in the tree view.

Enable IVR Reporting

This option determines whether or not reporting data will be collected when control passes through this node. Several IVR Reports summarize this information. IVR Reporting is *disabled* by default. Enable it to capture the date, time and duration of time that the call remained in the node and its children. This option is hidden when Attendant is connected to a server that does not have reporting installed. For more information about this feature, see [IVR Reporting Option](#).

Add entry to the Interaction Log

When this option is enabled, information about this node is appended to the call's Interaction Log when the call enters this node. This helps track the path that a call took through Attendant. The Interaction Log is maintained for reporting purposes. See [View the Interaction Log](#) for details.

Audio Message to play to the caller frame

You can play a standard message that tells the caller his or her position in the queue, or the estimated wait time. Alternately, you can play a custom message to the caller.

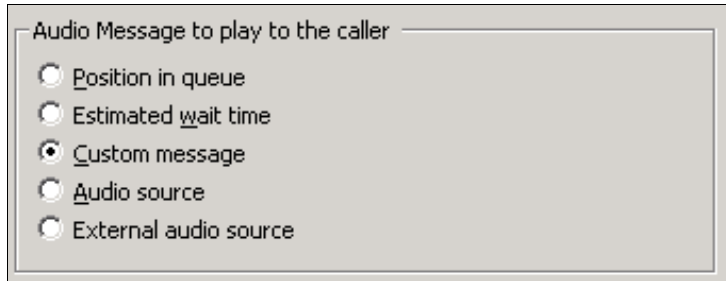

Position in Queue

Plays a message that tells the caller his position in the queue.

Estimated wait time

Plays a message that tells the caller how long it may be until his call is answered.

Custom Message

Enables embedded audio controls in the Audio File frame, so that you can record or select a previously record .wav file. For procedural details, see [manage voice prompts](#).

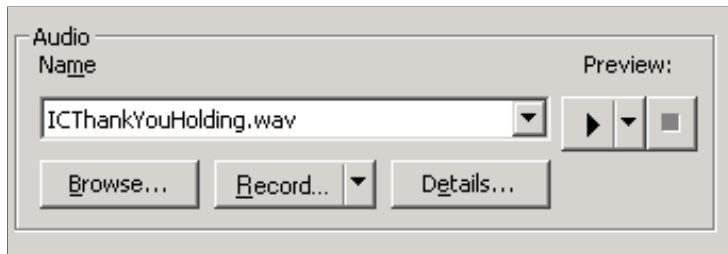

Audio Source

When you select *Audio Source*, the embedded audio controls allow the selection of any audio source defined in Interaction Administrator. In the *Audio Source Settings* area, optionally select the Play Source Continually to play the audio source on a continues loop or set a Timeout value to indicate the number of seconds to play the audio source before exiting playback.

Setting a Timeout of 0 seconds or choosing Play Source Continuously plays the audio source until the call is answered or the Group Transfer node reaches a configured timeout and passes control to its action.

Each play of an audio source begins from a random location.

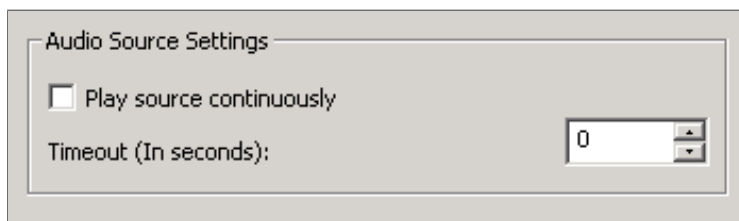

Note: The maximum Timeout is 600 seconds for Audio source.

Below the *Audio Source Settings* area, in the *Audio* area click the Name dropdown list to select any audio source that is defined in Interaction Administrator, all other functions are disabled.

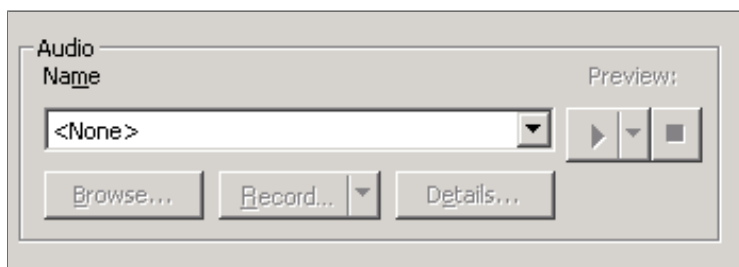

External audio source

If you click *External Audio Source*, in the Audio Source Settings area optionally select the Play Source Continually to configure Interaction Attendant to play the external audio repeatedly. In the Timeout area, use the up and down arrows to select the configurable number of seconds to repeat the audio before exiting playback.

Below the Audio Source Settings, click the arrow at the end of the Name field dropdown list and select the appropriate source (for example, iPod or Pandora). Interaction Attendant will play audio from a file or audio source to a user in the IVR. These external audio sources must be defined and configured in Interaction Administrator before you can select them in the Queue Audio node.

After you select the external audio source, in the *Timeout* area use the up and down arrows to select how many seconds to play the external audio source before control is passed to Action When Finished processing.

Present a Menu to the caller

This operation (also called Queue Menu) presents the caller with menu choices while he or she waits in the queue. The message is configurable. A queue menu works like a standard menu, except that a limited set of operations can be attached to it. The supported operations are *Callback Request*, *Disconnect*, *Queue Operations*, *Transfer to a Different Menu*, *Transfer to Voicemail*, and *Transfer to an Attendant Profile*.

All Queue operations are disabled until a [Group Transfer](#) node is configured to transfer to an ACD workgroup. This operation is disabled in the toolbar unless one of the other [queue operations](#) is selected in the tree view.

Node Characteristics frame

Options in this frame name the node, assign the digit used to select it, and establish whether or not it is active, logged, or tracked for reporting purposes. You cannot configure this node as a default action, since this operation is not invoked in response to a key press.

Name field

The label you enter here becomes the name of the node in the tree structure.

Digit list box

Use this list to select the key that callers press to enter a caller data entry operation. When you assign a digit, the list displays only available digits—those that are not already in use at this level of the tree. If no digit is assigned, callers cannot invoke the operation directly. It is possible to create menu options that are invoked by a routing process, rather than by a user selection. For details, see [invoke a menu operation automatically](#).

Active check box

By default, forms are "on", or "active", which means that Interaction Attendant will process them. If you uncheck a form's Active check box, the name of the node turns gray in the tree to indicate that the form is inactive. Interaction Attendant and its [handlers](#) will thereafter ignore the form and its children. Use this feature to save a configuration that you are testing. Inactive forms are invisible to callers. When a node is inactive, it appears grayed out in the tree view.

Default Action check box

At any given "level" in the tree structure, one node can be marked as the default action. The operation defined by the [default node](#) is performed if the caller does not press a key within the timeout period specified by that menu. The icon for default forms has a green border in the tree structure. Any node below a menu or schedule can be marked as the [default action](#), by checking the form's default action check box.

Enable IVR Reporting

This option determines whether or not reporting data will be collected when control passes through this node. Several IVR Reports summarize this information. IVR Reporting is *disabled* by default. Enable it to capture the date, time and duration of time that the call remained in the node and its children. This option is hidden when Attendant is connected to a server that does not have reporting installed. For more information about this feature, see [IVR Reporting Option](#).

Add entry to the Interaction Log

When this option is enabled, information about this node is appended to the call's Interaction Log when the call enters this node. This helps track the path that a call took through Attendant. The Interaction Log is maintained for reporting purposes. See [View the Interaction Log](#) for details.

Configure Speech Recognition... button

Select this button to configure words or phrases that can be associated with menu options. Callers can verbally indicate the options they want in the IVR instead of pressing a digit on the phone. You can enter multiple words and phrases for each menu item, just as callers may phrase the same request in different ways. For example, "transfer funds" or "funds transfer". See [Add Speech Recognition keywords or phrases to Inbound Call Operations](#).

Note: Speech Recognition will not be executed for Queue Operation after a Workgroup transfer in the IVR. Audio File frame

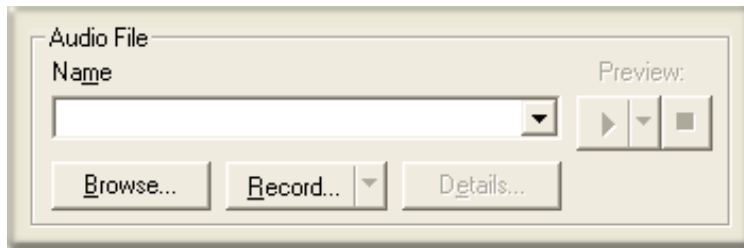

The [embedded audio controls](#) in this frame manage a prompt that plays when the menu is invoked. In most cases this voice prompt tells the caller which keys to press to make menu choices. See [manage voice prompts](#) for procedural details.

Timeout frame

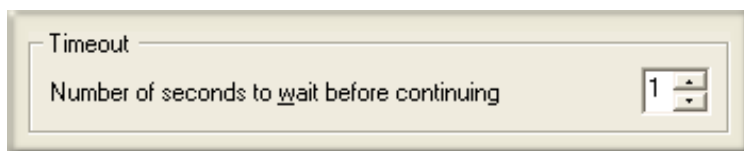

Number of seconds to wait before continuing spin control

This spin control sets the interval that Interaction Attendant will wait after playing an audio message, before moving to the next queue operation if the caller does not make a menu selection.

In xIC 2.3 and later, queue operations that require ACD workgroups (queue audio, queue menu, queue repeat) are disabled when a non-ACD workgroup queue is selected. These operations are automatically enabled in toolbars and menus when an ACD workgroup is selected in the node that the operation is attached to.

In previous releases, it was possible to create queue nodes that did not execute for sequential or group workgroups. For example, one could have set a queue audio node to play a .wav file under a sequential or group ring group transfer node. When a call came into that queue, the caller heard the default hold music while any available agents are alerted. If the call was not answered, it was forwarded to the group's Voicemail. On a sequential workgroup, when there were no available agents, the call went directly to Voicemail and the queue audio was never played.

Repeat a sequence of Queue operations

This operation loops back to a previous Queue Menu node in the queue processing. This operation is disabled in the toolbar unless one of the other [queue operations](#) is selected in the tree. This operation is also called Queue Repeat.

Queue Repeat repeats the node it points to the number of times selected before continuing with the queue processing. This is typically used for things like playing 15 second hold music for 45 seconds before repeating the position in queue audio.

In xIC 2.3 and later, queue operations that require ACD workgroups (queue audio, queue menu, queue repeat) are disabled when a non-ACD workgroup queue is selected. These operations are automatically enabled in toolbars and menus when an ACD workgroup is selected in the node that the operation is attached to.

In previous releases, it was possible to create queue nodes did not execute for sequential or group workgroups. For example, one could have set a queue audio node to play a .wav file under a sequential or group ring group transfer node. When a call came into that queue, the caller heard the default hold music while any available agents are alerted. If the call was not answered, it was forwarded to the group's Voicemail. On a sequential workgroup, when there were no available agents, the call went directly to Voicemail and the queue audio was never played.

Node Characteristics frame

Options in this frame name the node, assign the digit used to select it, and establish whether or not it is active, logged, or tracked for reporting purposes. You cannot configure this node as a default action, since this operation is not invoked in response to a key press.

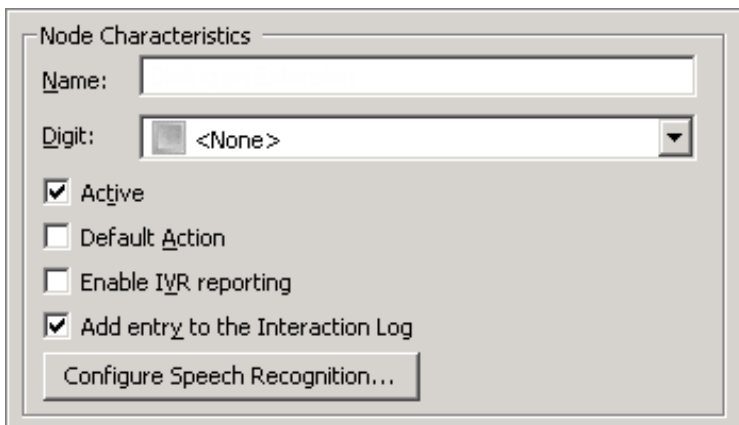

The screenshot shows a dialog box titled "Node Characteristics". It contains the following elements:

- A text field labeled "Name:".
- A dropdown menu labeled "Digit:" with "<None>" selected.
- Four checkboxes:
 - Active
 - Default Action
 - Enable IVR reporting
 - Add entry to the Interaction Log
- A button labeled "Configure Speech Recognition..."

Name field

The label you enter here becomes the name of the node in the tree structure.

Digit list box

Use this list to select the key that callers press to enter a caller data entry operation. When you assign a digit, the list displays only available digits—those that are not already in use at this level of the tree. If no digit is assigned, callers cannot invoke the operation directly. It is possible to create menu options that are invoked by a routing process, rather than by a user selection. For details, see [invoke a menu operation automatically](#).

Active check box

By default, forms are "on", or "active", which means that Interaction Attendant will process them. If you uncheck a form's Active check box, the name of the node turns gray in the tree to indicate that the form is inactive. Interaction Attendant and its [handlers](#) will thereafter ignore the form and its children. Use this feature to save a configuration that you are testing. Inactive forms are invisible to callers. When a node is inactive, it appears grayed out in the tree view.

Default Action check box

At any given "level" in the tree structure, one node can be marked as the default action. The operation defined by the [default node](#) is performed if the caller does not press a key within the timeout period specified by that menu. The icon for default forms has a green border in the tree structure. Any node below a menu or schedule can be marked as the [default action](#), by checking the form's default action check box.

Enable IVR Reporting

This option determines whether or not reporting data will be collected when control passes through this node. Several IVR Reports summarize this information. IVR Reporting is *disabled* by default. Enable it to capture the date, time and duration of time that the call remained in the node and its children. This option is hidden when Attendant is connected to a server that does not have reporting installed. For more information about this feature, see [IVR Reporting Option](#).

Add entry to the Interaction Log

When this option is enabled, information about this node is appended to the call's Interaction Log when the call enters this node. This helps track the path that a call took through Attendant. The Interaction Log is maintained for reporting purposes. See [View the Interaction Log](#) for details.

Configure Speech Recognition... button

Select this button to configure words or phrases that can be associated with menu options. Callers can verbally indicate the options they want in the IVR instead of pressing a digit on the phone. You can enter multiple words and phrases for each menu item, just as callers may phrase the same request in different ways. For example, "transfer funds" or "funds transfer". See [Add Speech Recognition keywords or phrases to Inbound Call Operations](#).

Transfer the call back to this location frame

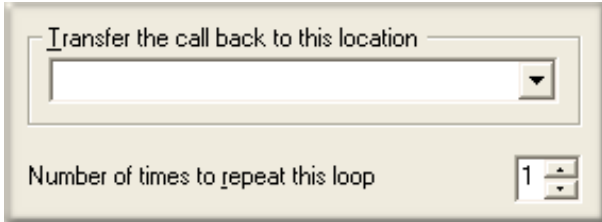

Transfer list box

Selects a queue node to transfer the call to.

Number of times to repeat this loop spin control

Sets the maximum number of times that the loop will be executed before control is passed to the error handler for the schedule.

Related Topics

- [Queue Operations](#)



Transfer the call out of this queue

This operation transfers a call directly to a user, workgroup, or station queue. It transfers the call out of this queue and into another queue. If the call is not picked up, the call will wait in the workgroup queue until it is answered. This operation is also called Queue Transfer. It is disabled in the toolbar unless one of the other [queue operations](#) is selected in the tree.

This operation must be the child of a Queue Menu node.

Node Characteristics frame

Options in this frame name the node, assign the digit used to select it, and establish whether or not it is active, used by default, logged, or tracked for reporting purposes.

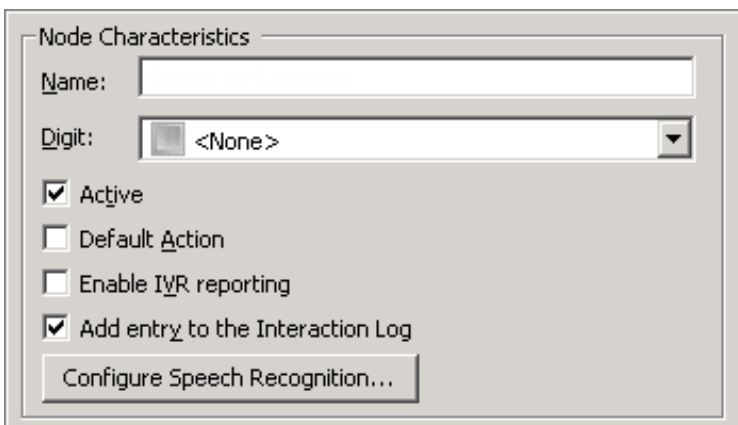

Name field

The label you enter here becomes the name of the node in the tree structure.

Digit list box

Use this list to select the key that callers press to enter a caller data entry operation. When you assign a digit, the list displays only available digits—those that are not already in use at this level of the tree. If no digit is assigned, callers cannot invoke the operation directly. It is possible to create menu options that are invoked by a routing process, rather than by a user selection. For details, see [invoke a menu operation automatically](#).

Active check box

By default, forms are "on", or "active", which means that Interaction Attendant will process them. If you uncheck a form's Active check box, the name of the node turns gray in the tree to indicate that the form is inactive. Interaction Attendant and its [handlers](#) will thereafter ignore the form and its children. Use this feature to save a configuration that you are testing. Inactive forms are invisible to callers. When a node is inactive, it appears grayed out in the tree view.

Default Action check box

At any given "level" in the tree structure, one node can be marked as the default action. The operation defined by the [default node](#) is performed if the caller does not press a key within the timeout period specified by that menu. The icon for default forms has a green border in the tree structure. Any node below a menu or schedule can be marked as the [default action](#), by checking the form's default action check box.

Enable IVR Reporting

This option determines whether or not reporting data will be collected when control passes through this node. Several IVR Reports summarize this information. IVR Reporting is *disabled* by default. Enable it to capture the date, time and duration of time that the call remained in the node and its children. This option is hidden when Attendant is connected to a server that does not have reporting installed. For more information about this feature, see [IVR Reporting Option](#).

Add entry to the Interaction Log

When this option is enabled, information about this node is appended to the call's Interaction Log when the call enters this node. This helps track the path that a call took through Attendant. The Interaction Log is maintained for reporting purposes. See [View the Interaction Log](#) for details.

Configure Speech Recognition... button

Select this button to configure words or phrases that can be associated with menu options. Callers can verbally indicate the options they want in the IVR instead of pressing a digit on the phone. You can enter multiple words and phrases for each menu item, just as callers may phrase the same request in different ways. For example, "transfer funds" or "funds transfer". See [Add Speech Recognition keywords or phrases to Inbound Call Operations](#).

Workgroup, Call Priority and Skill Settings

Selects the queue that the call is transferred to, allowing you to set priority and skill settings.

Call processing behavior after the call is transferred to a queue is affected by post-queue-transfer [IVR](#) handlers (handlers and subsequent handlers called from System_CallOfferingNonSystemQueue.ihd). For example, if you add a workgroup queue in Interaction Administrator and make a call to that queue from Interaction Attendant, the call will not be processed unless you have modified the CustomIVRWorkgroup queue to process calls sent to that workgroup. In short, Interaction Attendant tells CIC that a call is being transferred to a non-system queue, and System_CallOfferingNonSystemQueue.ihd takes over from there.

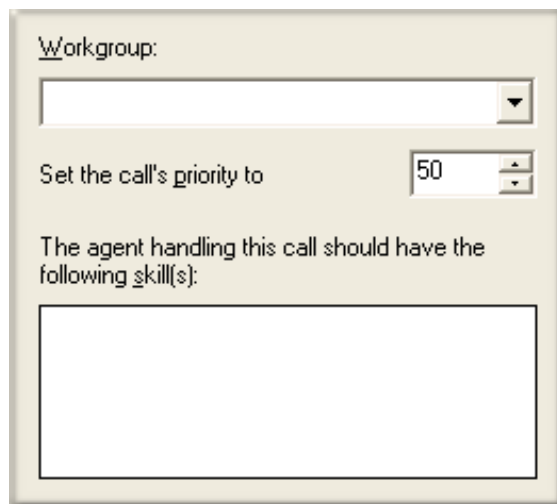

Workgroup list box

This list box contains the names of destination workgroups.

Set the calls priority to

You can change the priority of the call before sending it to the queue. (0=lowest, 1000=highest). By default, the call priority is 50.

Agent Skills

These check boxes are used in conjunction with ACD to route the call to an agent whose skills match the profiles you select.

Callback Request

The **Request Callback** node allows a caller to request a callback. ANI data about the call is examined at runtime to capture the caller's telephone number, and a new callback request object is placed on the workgroup queue specified in the form. The callback occurs when an agent picks up the callback from the queue. Attendant currently does not allow callers to schedule callbacks to occur at a specific date or time.

Callbacks increase customer satisfaction, since a caller does not have to wait on hold or possibly incur long distance charges while waiting to speak with an agent.

Callers who are on hold for a workgroup can transfer to another group, disconnect, leave a Voicemail message, or request that an agent return the call. If the existing call is ACD, the call will be replaced with a callback object, and the ACD stats will be copied over to the callback object: priority, time in queue, workgroup queue, and skills. This can be confirmed by examining the ACDServer logs. If the existing call is NOT ACD, a new callback object will be created on the specified workgroup queue. If the Request Callback node is not part of queue operations, you are presented with the option to select a target workgroup.

>In-Queue menus

If the **Request Callback** node is part of queue operations, you can configure a prompt to inform the caller that the system successfully processed and scheduled the callback. This frame only appears in an in-queue menu.

If the **Request Callback** is part of an in-queue menu that includes a **Caller Data Entry** node, the caller can enter a specific telephone number during a callback request and Interaction Attendant will pull that number from the Caller Data Entry node when processing the callback request. In the **Callback Number** frame, select the **Callback to the phone number entered by the caller in this Caller Data Entry** node radio button and from the dropdown list select the **Caller Data Entry** node listed in the in-queue menu.

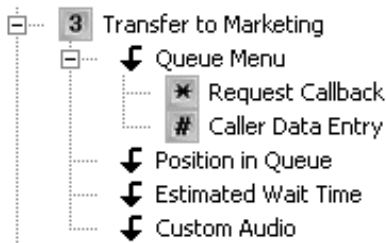

Note: Make sure you also configure the **Caller Data Entry** node's **Action When Finished** frame to jump to the appropriate **Request Callback** node listed in the in-queue menu.

Node Characteristics frame

Options in this frame name the node, assign the digit used to select it, and establish whether or not it is active, used by default, logged, or tracked for reporting purposes.

Name field

The label you enter here becomes the name of the node in the tree structure.

Digit list box

Use this list to select the key that callers press to enter a caller data entry operation. When you assign a digit, the list displays only available digits—those that are not already in use at this level of the tree. If no digit is assigned, callers cannot invoke the operation directly. It is possible to create menu options that are invoked by a routing process, rather than by a user selection. For details, see [invoke a menu operation automatically](#).

Active check box

By default, forms are "on", or "active", which means that Interaction Attendant will process them. If you uncheck a form's Active check box, the name of the node turns gray in the tree to indicate that the form is inactive. Interaction Attendant and its [handlers](#)

will thereafter ignore the form and its children. Use this feature to save a configuration that you are testing. Inactive forms are invisible to callers. When a node is inactive, it appears grayed out in the tree view.

Default Action check box

At any given "level" in the tree structure, one node can be marked as the default action. The operation defined by the [default node](#) is performed if the caller does not press a key within the timeout period specified by that menu. The icon for default forms has a green border in the tree structure. Any node below a menu or schedule can be marked as the [default action](#), by checking the form's default action check box.

Enable IVR Reporting

This option determines whether or not reporting data will be collected when control passes through this node. Several IVR Reports summarize this information. IVR Reporting is *disabled* by default. Enable it to capture the date, time and duration of time that the call remained in the node and its children. This option is hidden when Attendant is connected to a server that does not have reporting installed. For more information about this feature, see [IVR Reporting Option](#).

Add entry to the Interaction Log

When this option is enabled, information about this node is appended to the call's Interaction Log when the call enters this node. This helps track the path that a call took through Attendant. The Interaction Log is maintained for reporting purposes. See [View the Interaction Log](#) for details.

Configure Speech Recognition... button

Select this button to configure words or phrases that can be associated with menu options. Callers can verbally indicate the options they want in the IVR instead of pressing a digit on the phone. You can enter multiple words and phrases for each menu item, just as callers may phrase the same request in different ways. For example, "transfer funds" or "funds transfer". See [Add Speech Recognition keywords or phrases to Inbound Call Operations](#).

Audio File frame

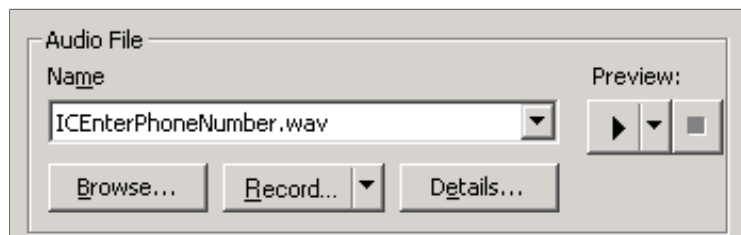

Controls in this frame set a prompt to play when control is passed to this form. If you do not select or record a prompt using the [embedded audio controls](#), no voice prompting will occur. See [manage voice prompts](#) for details.

Announce Callback Scheduled frame (In-Queue menus only)

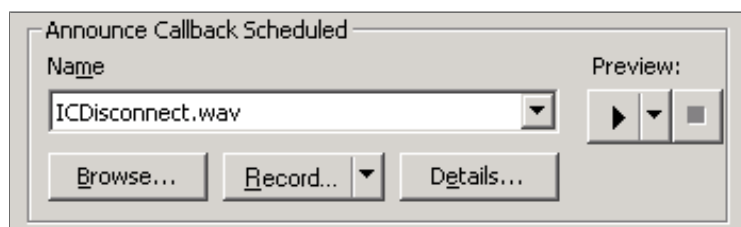

If the callback node is part of queue operations, you can configure a prompt that confirms to the caller the system processed and scheduled the callback. This frame only appears in an in-queue menu.

Callback Number frame

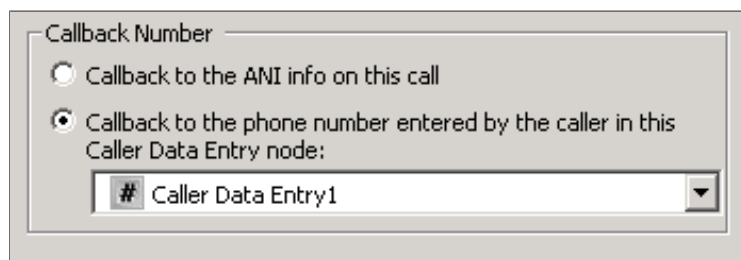

The settings in this frame determine the telephone number used to call back the user, which can be:

Callback to the ANI info on this call

The return call will be placed to the caller's telephone number.

Callback to the phone number entered by the call in this Call Data Entry node

Places a call to the number entered in the selected *Caller Data Entry* node, which prompted the caller to enter a string of digits using their telephone keypad.

Workgroup Queue (not available within In-Queue menus)

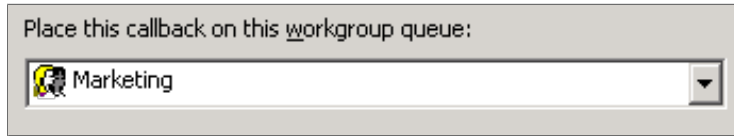

If the callback node is not part of queue operations, you are presented with the option to select a target workgroup:

Place this callback on this workgroup queue list box

This list selects the queue that the callback will be placed on.

Microsoft Dynamics CRM Operations

Email Operations

The following nodes perform actions on Email objects:

Node	Action
Build Email Reply	Allows the user to configure specific attributes of a message that will be sent in response to the inbound email. Additionally, the user can select the processing that will occur after the reply has been built.
Email - Disconnect	Stops processing an email message. Messages can optionally be stored in a folder.
Email Transfer	Branches between two possible operations based upon the result of a <i>rule</i> . A rule is a logical expression based on the email address, subject, or body text that evaluates to True or False. If the rule evaluates as True, then the flow will jump to one node; if the rule is False, then the flow will jump to another node.
Email - Run Subroutine	Passes the current email object to a custom handler. The processing that the subroutine performs occurs is up to the handler author.
Email - Logging	Writes free-form text, the date and time, or selected parts of the email to the interaction log.
Email - Set Attribute	Assigns a named item of information to the email which travels with it throughout the Customer Interaction Center.
Email - Set Routing Options	These options assign required agent skills and/or queue priority used for Workgroup routing in advance of actually performing the Email Workgroup Transfer.
Email - Transfer to an Agent	Sends an email interaction to a specific user queue .
Email - Transfer to a Different Menu	Jumps to any location in the configuration tree.
Email - Transfer to a Workgroup	Transfers an email interaction to a workgroup. If the destination workgroup is an ACD workgroup, you can optionally select skills that the Agent handling the interaction must have to receive the Interaction.

Related Topics

- [Email Profiles](#)
- [Email Schedules](#)
- [Email Operations](#)

Email - Build Reply

The Build Reply form allows the user to configure specific attributes of a message that will be sent in response to the inbound Email. Additionally, the user can select the processing that will occur after the reply has been built.

- Send the reply and then stop processing (strictly an auto-response)
- Send the reply and continue processing (for things like "We got your message and we will respond soon...")

Email nodes are processed in top-to-bottom order under a schedule.

Node Characteristics frame

Options in this frame name the node, and establish whether or not it is active, logged, or tracked for reporting purposes.

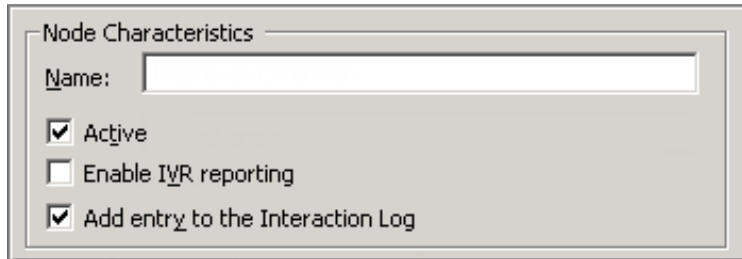

Name field

The label you enter here becomes the name of the node in the tree structure.

Active check box

By default, forms are "on", or "active", which means that Interaction Attendant will process them. If you uncheck a form's Active check box, the name of the node turns gray in the tree to indicate that the form is inactive. Interaction Attendant and its [handlers](#) will thereafter ignore the form and its children. Use this feature to save a configuration that you are testing. Inactive forms are invisible to callers. When a node is inactive, it appears grayed out in the tree view.

Enable IVR Reporting

This option determines whether or not reporting data will be collected when control passes through this node. Several IVR Reports summarize this information. IVR Reporting is *disabled* by default. Enable it to capture the date, time and duration of time that the call remained in the node and its children. This option is hidden when Attendant is connected to a server that does not have reporting installed. For more information about this feature, see [IVR Reporting Option](#).

Add entry to the Interaction log

When this option is enabled, information about this node is appended to the call's Interaction Log when the call enters this node. This helps track the path that a call took through Attendant. The Interaction Log is maintained for reporting purposes. See [View the Interaction Log](#) for details.

Reply to Sender frame

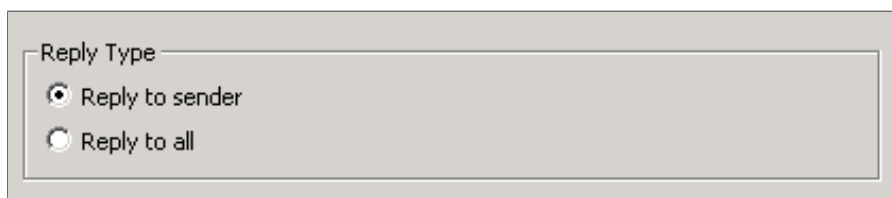

Reply to sender

Sends the reply using the address of the person who sent the Email.

Reply to all

Sends the reply to all persons who originally received the Email.

Reply Process frame

Reply Process

Send reply now and disconnect

Send reply now and continue processing

Send reply now and disconnect

Sends reply and terminates the interaction. No other nodes will process this Email.

Send reply now and continue processing

Sends the Email but does not terminate the interaction. Control is passed to the next node below the current one.

Routing and Message Body Options

You can manually type an Email address in any of the address fields in the form *username@somedomain.com*. However, no address validation occurs unless you use the [Email Address Selection dialog](#) to select an address.

Send Message From ->

Reply To Address(es) ->

Add Cc: Address(es) ->

Add Bcc: Address(es) ->

Include original message in reply

Include original attachments in reply

Message Text

Send Message From

Click the **Send Message From** button to open the [Email Address Selection dialog](#) and search for and select Email addresses. The resulting text string specifies the address that will be used as the From address.

In the **Send Message From** field, you can enter a string of the email address or a string of the display name with the email address.

Examples:

bojo@xyz.com

Boris Johnson|bojo@xyz.com

Reply To Address(es)

Click the **Reply To Address(es)** button to open the [Email Address Selection dialog](#) and search for and select addresses. The resulting text string specifies the addresses that should be used as the Reply To address.

In the **Reply to Address(es)** field, you can enter a string of the email address or a string of the display name with the email address.

Examples:

bojo@xyz.com

bojo@xyz.com;tsmith@abc.com

Boris Johnson|bojo@xyz.com

Boris Johnson|bojo@xyz.com;tsmith@abc.com

margin-left: .25in; margin-right: 0in;

Important: "Reply to Address(es)" specifies the person that the message is sent to by Attendant, not the original sender. When a user opens the message in a client application, and chooses to reply, the Reply To address (specified in the Build Reply node) is not used. The message is sent to the sender of the original Email, or to all persons who received the original Email, based on whether "Reply to Sender" or "Reply to all" was selected in the Build Reply node.

Add Cc: Address(es)

Click the **Add Cc: Address(es)** button to open the [Email Address Selection dialog](#) and search for and select addresses. The resulting text string specifies address(es) that will be appended to the end of the current list of carbon copy (Cc) addresses for the reply.

In the **Add Cc: Address(es)** field, you can enter a string of the email address or a string of the display name with the email address.

Examples:

bojo@xyz.com

bojo@xyz.com;tsmith@abc.com

Boris Johnson|bojo@xyz.com

Boris Johnson|bojo@xyz.com;tsmith@abc.com

Add Bcc: Address(es)

Click the **Add Bcc: Address(es)** button to open the [Email Address Selection dialog](#) and search for and select addresses. The resulting text string specifies address(es) that will be appended to the end of the current list of blind carbon copy (Bcc) addresses for the reply.

In the **Add Bcc: Address(es)** field, you can enter a string of the email address or a string of the display name with the email address.

Examples:

bojo@xyz.com

bojo@xyz.com;tsmith@abc.com

Boris Johnson|bojo@xyz.com

Boris Johnson|bojo@xyz.com;tsmith@abc.com

Include original message in reply

Use this option to include the text of the original message in the response message. If you select this checkbox,

Include original attachments in reply

Use this option to include the original message file attachments with the response message.

Message Text field

The text you enter in this field becomes the body text of the reply that is being built, replacing the original body text of the message. The text will appear in plain text format. HTML tags are not supported and although they may work as desired, the tags will appear in the plain text body of the message.

If you choose to include the original text in the message body by selecting the *Include original message in reply* check box, the text you enter into the Message Text field will be added to the body of the message.

Related Topics

- [Email Profiles](#)
- [Email Schedules](#)
- [Email Operations](#)

Email - Disconnect

The email disconnect node stops processing an email message. Messages can optionally be stored in a folder.

Node Characteristics frames

Options in this frame name the node, and establish whether or not it is active, logged, or tracked for reporting purposes.

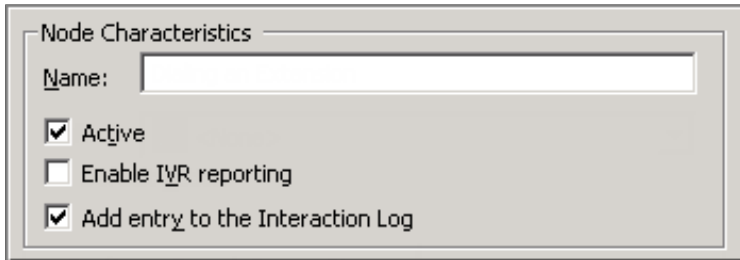

Name field

The label you enter here becomes the name of the node in the tree structure.

Active check box

By default, forms are "on", or "active", which means that Interaction Attendant will process them. If you uncheck a form's Active check box, the name of the node turns gray in the tree to indicate that the form is inactive. Interaction Attendant and its [handlers](#) will thereafter ignore the form and its children. Use this feature to save a configuration that you are testing. Inactive forms are invisible to callers. When a node is inactive, it appears grayed out in the tree view.

Enable IVR Reporting

This option determines whether or not reporting data will be collected when control passes through this node. Several IVR Reports summarize this information. IVR Reporting is *disabled* by default. Enable it to capture the date, time and duration of time that the call remained in the node and its children. This option is hidden when Attendant is connected to a server that does not have reporting installed. For more information about this feature, see [IVR Reporting Option](#).

Add entry to the Interaction log

When this option is enabled, information about this node is appended to the call's Interaction Log when the call enters this node. This helps track the path that a call took through Attendant. The Interaction Log is maintained for reporting purposes. See [View the Interaction Log](#) for details.

Action on Disconnect frame



Move the e-mail to a folder

You can optionally move an email to a folder, rather than discard it. This option stores the message until it can be manually processed, and allows Attendant to be configured as a lightweight "spam filter". The logic for determining what is spam must be user-configured by creating additional Email Profiles or by using [Email Transfer nodes](#).

Mailbox

Select a destination mailbox by pressing the browse (...) button. The [Mailbox Selection](#) dialog will appear. Select a mailbox, and then press OK to dismiss the dialog.

Note: If you use Microsoft Exchange Web Services, select a folder in the same mailbox from which the email was queued.

Folder

When the drop list is enabled, you can select from a list of destination folders in the selected mailbox. The message will be transferred to the selected folder and processing of the interaction will be halted.

Related Topics

- [Email Profiles](#)
- [Email Schedules](#)
- [Email Operations](#)

Email - Transfer

An *Email Transfer* node branches between two flow of control paths based upon the result of a rule. This works like a Logical Transfer for a call, except that an email message is transferred instead of a telephone call. A rule is a logical expression based on the email address, subject, or body text that evaluates to True or False. If the rule evaluates as True, then the flow will jump to one node; if the rule is False, then the flow will jump to another node.

Node Characteristics frame

Options in this frame name the node, and establish whether or not it is active, logged, or tracked for reporting purposes.

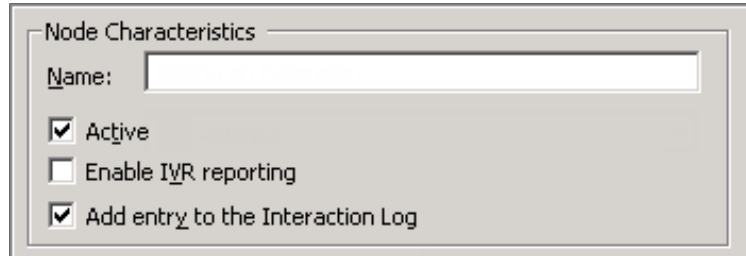

Name field

The label you enter here becomes the name of the node in the tree structure.

Active check box

By default, forms are "on", or "active", which means that Interaction Attendant will process them. If you uncheck a form's Active check box, the name of the node turns gray in the tree to indicate that the form is inactive. Interaction Attendant and its [handlers](#) will thereafter ignore the form and its children. Use this feature to save a configuration that you are testing. Inactive forms are invisible to callers. When a node is inactive, it appears grayed out in the tree view.

Enable IVR Reporting

This option determines whether or not reporting data will be collected when control passes through this node. Several IVR Reports summarize this information. IVR Reporting is *disabled* by default. Enable it to capture the date, time and duration of time that the call remained in the node and its children. This option is hidden when Attendant is connected to a server that does not have reporting installed. For more information about this feature, see [IVR Reporting Option](#).

Add entry to the Interaction log

When this option is enabled, information about this node is appended to the call's Interaction Log when the call enters this node. This helps track the path that a call took through Attendant. The Interaction Log is maintained for reporting purposes. See [View the Interaction Log](#) for details.

Email conditions frame

This frame displays the rule that was previously created using the Email Rule wizard, or "No email conditions defined", if the rule has not been created yet.

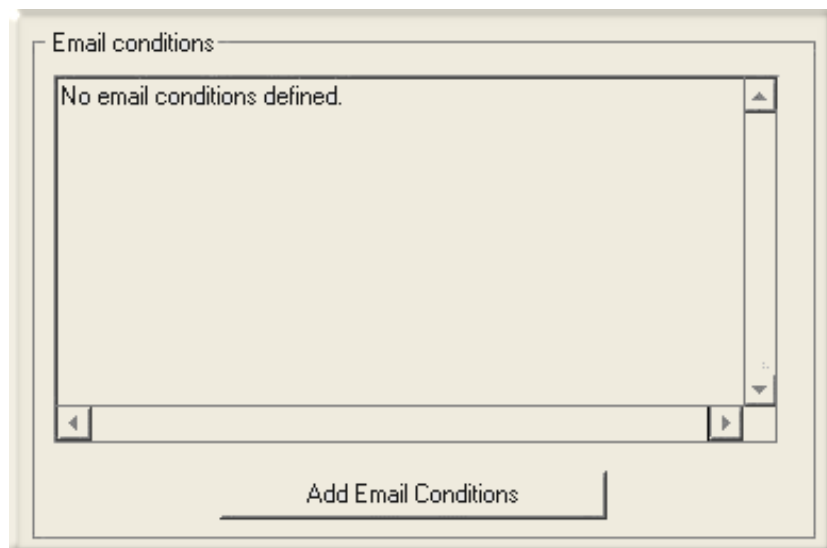

Add Email Conditions button

Opens the [Rules](#) wizard for emails. Once an expression has been defined, the button caption changes to "Modify Email Condition". If you press the button a second time, you are given the opportunity to change you selections.

Transfer Location frame

This frame sets the paths that are taken after the logical expression is evaluated. One path is taken when the expression is True. The other path is taken when the expression is False.

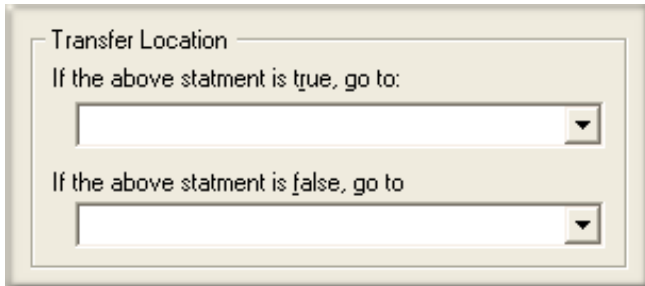

If the above statement is true, go to...

This list box allows you to select the path that is taken when the expression is True. You can select any [profile](#), [schedule](#), [menu](#), or [operation](#) that is defined for the current server.

If the above statement is false, go to...

This list box allows you to select the path that is taken when the expression is False. You can select any [profile](#), [schedule](#), [menu](#), or [operation](#) that is defined for the current server.

Related Topics

- [Email Rules Wizard](#)
- [Email Profiles](#)
- [Email Schedules](#)
- [Email Operations](#)

Email - Run Subroutine

This node passes the current email object to a custom handler. The processing that the subroutine performs occurs is up to the handler author. This node is sometimes called "Subroutine Initiator", since it allows a custom handler to take over processing of an interaction. The custom handler usually accomplishes functionality outside of the scope of Attendant's built-in nodes.

Important: Before using Run Subroutine in Interaction Attendant, you must modify the CustomSubroutineInitiatorRouter handler using Interaction Designer. See [Modify CustomSubroutineInitiator.ihd](#) for procedural details. Interaction Designer's online help provides comprehensive information about handlers and subroutines.

Node Characteristics frame

Options in this frame name the node, and establish whether or not it is active, logged, or tracked for reporting purposes.

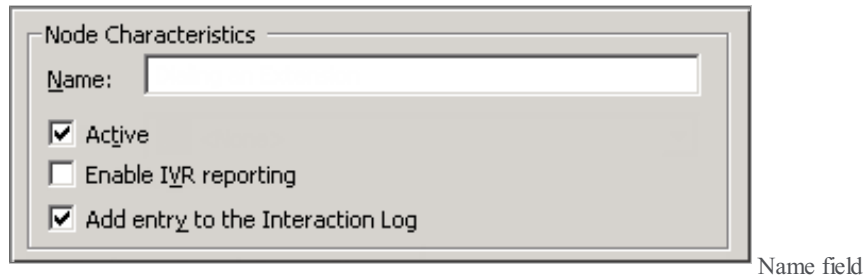

The label you enter here becomes the name of the node in the tree structure.

Active check box

By default, forms are "on", or "active", which means that Interaction Attendant will process them. If you uncheck a form's Active check box, the name of the node turns gray in the tree to indicate that the form is inactive. Interaction Attendant and its [handlers](#) will thereafter ignore the form and its children. Use this feature to save a configuration that you are testing. Inactive forms are invisible to callers. When a node is inactive, it appears grayed out in the tree view.

Enable IVR Reporting

This option determines whether or not reporting data will be collected when control passes through this node. Several IVR Reports summarize this information. IVR Reporting is *disabled* by default. Enable it to capture the date, time and duration of time that the call remained in the node and its children. This option is hidden when Attendant is connected to a server that does not have reporting installed. For more information about this feature, see [IVR Reporting Option](#).

Add entry to the Interaction log

When this option is enabled, information about this node is appended to the call's Interaction Log when the call enters this node. This helps track the path that a call took through Attendant. The Interaction Log is maintained for reporting purposes. See [View the Interaction Log](#) for details.

Subroutine Name

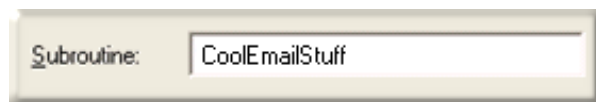

Subroutine name field

Type the name of the subroutine to run in this field. Attendant does not validate this entry, so be careful to enter a valid subroutine name. At runtime, the Subroutine Initiator will pass the interaction's identifier and the supplied subroutine name to a handler named CustomSubroutineInitiatorRouter, which in turn, invokes the subroutine.

Once control is passed to the subroutine, it does not return to Attendant. From Attendant's point of view, the interaction ends once the email is passed to the handler.

Related Topics

- [Email Profiles](#)
- [Email Schedules](#)
- [Email Operations](#)

Email – Logging

This node writes free-form text, the date and time, or selected parts of the email message to the interaction log.

Node Characteristics frame

Options in this frame name the node, and establish whether or not it is active, logged, or tracked for reporting purposes.

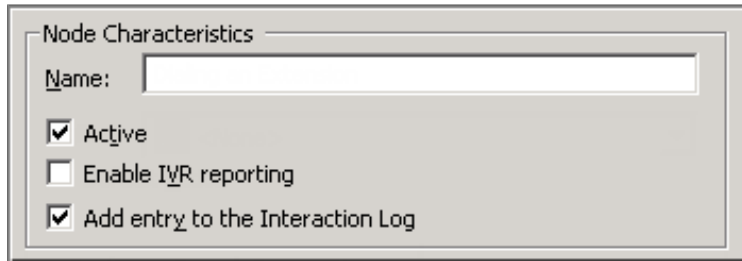

Name field

The label you enter here becomes the name of the node in the tree structure.

Active check box

By default, forms are "on", or "active", which means that Interaction Attendant will process them. If you uncheck a form's Active check box, the name of the node turns gray in the tree to indicate that the form is inactive. Interaction Attendant and its [handlers](#) will thereafter ignore the form and its children. Use this feature to save a configuration that you are testing. Inactive forms are invisible to callers. When a node is inactive, it appears grayed out in the tree view.

Enable IVR Reporting

This option determines whether or not reporting data will be collected when control passes through this node. Several IVR Reports summarize this information. IVR Reporting is *disabled* by default. Enable it to capture the date, time and duration of time that the call remained in the node and its children. This option is hidden when Attendant is connected to a server that does not have reporting installed. For more information about this feature, see [IVR Reporting Option](#).

Add entry to the Interaction log

When this option is enabled, information about this node is appended to the call's Interaction Log when the call enters this node. This helps track the path that a call took through Attendant. The Interaction Log is maintained for reporting purposes. See [View the Interaction Log](#) for details.

Logging Information frame

Options in this frame control what is written to the log file.

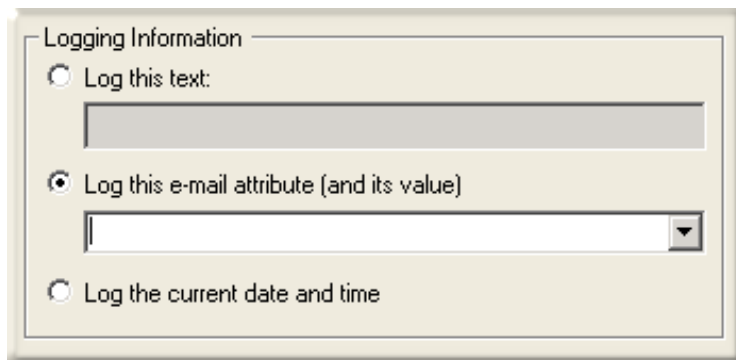

Log this text

Select this option to append free-form text to the interaction log.

Log this e-mail attribute (and its value)

This option writes one of the following attributes to the interaction log:

Data from the 'To:' field	Writes contents of the "To:" field to the log.
Data from the 'From:' field	Writes contents of the "From:" field to the log.
Date from the 'Cc:' field	Writes contents of the "Cc:" field to the log.
The subject line of the message	Writes the subject line of the email to the log.
The text of the message	Writes the entire email body to the log.
The subject line and message body	Writes the header, subject and body to the log.

Log the current date and time

This option appends the current date and time to the interaction log.

Related Topics

- [Email Profiles](#)
- [Email Schedules](#)
- [Email Operations](#)

Email - Set Attribute

An attribute is a piece of information about an object that travels with it throughout the Customer Interaction Center. Email interactions, like other objects in CIC, often have *attributes* assigned to them. Attributes are usually assigned by handlers, but Attendant allows the attributes of an object to be added or updated.

For example, one attribute of a call object is the telephone number of the person who placed the call. Attributes are name/value pairs. To set an attribute, specify its name, and a string value that you wish to assign to the attribute.

Setting an attribute does not modify the email message in any way, since the attribute is added to the interaction object, which carries the email message as a payload. Hence, attributes are characteristics of the email object, but not the email message.

The Set Attribute operation can assign a value to any attribute, including attributes that are reserved for use by important handlers in the Customer Interaction Center. If you modify a reserved attribute, you can adversely affect the performance or reliability of the server, so you should set attributes carefully.

The *Interaction Attributes Technical Reference* reports attributes that are reserved by CIC, including those which should not be changed.

Node Characteristics frame

Options in this frame name the node, and establish whether or not it is active, logged, or tracked for reporting purposes.

The screenshot shows a dialog box titled "Node Characteristics". It has a "Name:" label followed by a text input field. Below the input field are three checkboxes: "Active" (checked), "Enable IVR reporting" (unchecked), and "Add entry to the Interaction Log" (checked).

Name field

The label you enter here becomes the name of the node in the tree structure.

Active check box

By default, forms are "on", or "active", which means that Interaction Attendant will process them. If you uncheck a form's Active check box, the name of the node turns gray in the tree to indicate that the form is inactive. Interaction Attendant and its [handlers](#) will thereafter ignore the form and its children. Use this feature to save a configuration that you are testing. Inactive forms are invisible to callers. When a node is inactive, it appears grayed out in the tree view.

Enable IVR Reporting

This option determines whether or not reporting data will be collected when control passes through this node. Several IVR Reports summarize this information. IVR Reporting is *disabled* by default. Enable it to capture the date, time and duration of time that the call remained in the node and its children. This option is hidden when Attendant is connected to a server that does not have reporting installed. For more information about this feature, see [IVR Reporting Option](#).

Add entry to the Interaction log

When this option is enabled, information about this node is appended to the call's Interaction Log when the call enters this node. This helps track the path that a call took through Attendant. The Interaction Log is maintained for reporting purposes. See [View the Interaction Log](#) for details.

Attribute and Value fields

These fields identify the attribute to set, and assign a value to it.



Attribute text box

Type the name of the attribute in this text box. This name can be anything you like, or it can be the name of a reserved attribute. For example, a custom name might be "My Email Attribute".

For more information about attributes, refer to the *Interaction Attributes Technical Reference*, which is located in the PureConnect Documentation Library.

Value

Type the text you wish to assign to the attribute in this field. This can be anything you like. For example, "This interaction was processed by Attendant."

Tip for Advanced Users

Since the handler that supports Set Attribute node processes values through the ReplaceAttributes tool before it sets the target attribute, the Set Attribute node can be used to assign one attribute value to another, or you can use it to insert the value of an attribute along with a string literal. The syntax for inserting an attribute value is "\${attributename}".

To copy one attribute value into another:

Attribute name: SOME_ATTRIB
Value: \${SOME_OTHER_ATTRIB}

To copy literal text and an attribute value into another attribute:

Attribute name: SOME_ATTRIB
Value: The phone number is \${SOME_OTHER_ATTRIB}

Related Topics

- [Email Profiles](#)
- [Email Schedules](#)
- [Email Operations](#)

Email - Set Routing Options

This node sets required agent skills and/or queue priority used for Workgroup routing in advance of actually performing the Email Workgroup Transfer. This node makes it simpler to use the [Email Logical Transfer](#) node to determine if a call is high priority or needs certain skills and to route it appropriately.

The configuration options for this node are almost identical to options in the [Advanced Workgroup Properties Dialog \(Email\)](#) dialog. The user can select a priority between 1 and 100 to prioritize the email, and can select one or more skills that the agent taking the email should have. However, this node offers these additional features:

- A check box allows the user to control whether the message's priority should be set. This allows the user to set skills and leave the priority unaffected.
- Conversely, users can elect not to set skills, and set only priority, or they can append selected skills (to add more skills to the message), or "set to the selected skills", overwriting whatever skills were on the message with the skills selected in this node.

Node Characteristics frame

Options in this frame name the node, and establish whether or not it is active, logged, or tracked for reporting purposes.

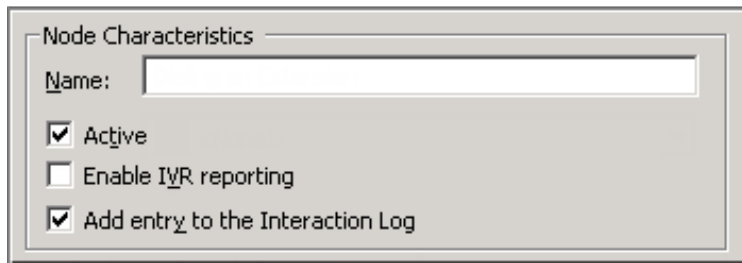
A configuration window titled "Node Characteristics" with a "Name:" label and an empty text input field. Below the input field are three checked checkboxes: "Active", "Enable IVR reporting", and "Add entry to the Interaction Log".

Name field

The label you enter here becomes the name of the node in the tree structure.

Active check box

By default, forms are "on", or "active", which means that Interaction Attendant will process them. If you uncheck a form's Active check box, the name of the node turns gray in the tree to indicate that the form is inactive. Interaction Attendant and its [handlers](#) will thereafter ignore the form and its children. Use this feature to save a configuration that you are testing. Inactive forms are invisible to callers. When a node is inactive, it appears grayed out in the tree view.

Enable IVR Reporting

This option determines whether or not reporting data will be collected when control passes through this node. Several IVR Reports summarize this information. IVR Reporting is *disabled* by default. Enable it to capture the date, time and duration of time that the call remained in the node and its children. This option is hidden when Attendant is connected to a server that does not have reporting installed. For more information about this feature, see [IVR Reporting Option](#).

Add entry to the Interaction log

When this option is enabled, information about this node is appended to the call's Interaction Log when the call enters this node. This helps track the path that a call took through Attendant. The Interaction Log is maintained for reporting purposes. See [View the Interaction Log](#) for details.

Priority frame

A configuration window titled "Priority" with a checked checkbox labeled "Enable priority" and a "Set email priority to:" label followed by a numeric input field containing the value "0".

Enable priority check box

This check box determines whether the message's priority is set. This allows you to set skills and leave the priority unaffected.

Set email priority to

Sets the priority of the email in a queue. Valid values range from 0 (lowest priority) to 100 (highest priority). The default is zero, which is the same as having no priority assigned.

Skills frame

Ignore skills

Select this option when you want to set priority, but not skills.

Append the selected skills

Add the skills you have selected to skills required to receive the message.

Set to the selected skills

Overwrites whatever skills are on the message with the skills selected.

Email - Transfer to an Agent

Agent Transfer sends an email interaction to a specific [user queue](#). This is the email equivalent of the [Transfer to an Agent](#) node for calls. The difference is that email messages cannot be transferred to stations.

To transfer email messages to a workgroup, use [Group Transfer](#) instead of *Transfer to an Agent*.

Node Characteristics frame

Options in this frame name the node, and establish whether or not it is active, logged, or tracked for reporting purposes.

Name field

The label you enter here becomes the name of the node in the tree structure.

Active check box

By default, forms are "on", or "active", which means that Interaction Attendant will process them. If you uncheck a form's Active check box, the name of the node turns gray in the tree to indicate that the form is inactive. Interaction Attendant and its [handlers](#) will thereafter ignore the form and its children. Use this feature to save a configuration that you are testing. Inactive forms are invisible to callers. When a node is inactive, it appears grayed out in the tree view.

Enable IVR Reporting

This option determines whether or not reporting data will be collected when control passes through this node. Several IVR Reports summarize this information. IVR Reporting is *disabled* by default. Enable it to capture the date, time and duration of time that the call remained in the node and its children. This option is hidden when Attendant is connected to a server that does not have reporting installed. For more information about this feature, see [IVR Reporting Option](#).

Add entry to the Interaction log

When this option is enabled, information about this node is appended to the call's Interaction Log when the call enters this node. This helps track the path that a call took through Attendant. The Interaction Log is maintained for reporting purposes. See [View the Interaction Log](#) for details.

Transfer To frame

The options in this frame determine whether email is transferred to a user queue or to an agent defined in the 'Eic_AttDynamicAgentName' interaction attribute. In general, you should specify a user queue when you need to route email to a specific person, and you should select the 'Eic_AttDynamicAgentName' interaction attribute when the user has been defined within the interaction attribute.

Note: The 'Eic_AttDynamicAgentName' interaction attribute is helpful for environments that contain a large number of users and allows you to designate a single user to the attribute, thereby alleviating the task of searching through the queue lists. See [Set Attribute](#) for details.

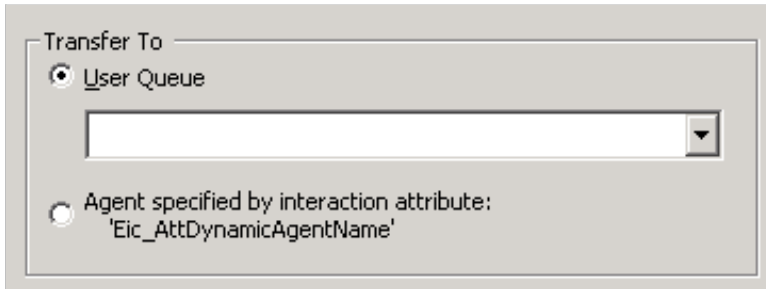

User Queue button

This radio button enables the User Queue drop down list.

User Queue drop down list

This drop down list contains the names of [user queues](#) defined for the current server. The queue you select becomes the destination for the call. Use this drop list to select a destination user queue.

Agent specified by interaction attribute radio button

This radio button specifies the user as defined in the 'Eic_AttDynamicAgentName' interaction attribute. The user defined in this interaction attribute becomes the destination for the email.

Park Interaction check box

Select this check box to allow email messages to be parked on another person's extension for the agent to receive when he or she has an available status.

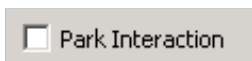

Related Topics

- [Email Profiles](#)
- [Email Schedules](#)
- [Email Operations](#)

Email - Transfer to a Different Menu

The Menu Transfer for calls allow a call to jump from one location in attendant to another. This same functionality is implemented for email routing tools, but, since there are no "menu" nodes in an email call flow, the Menu Transfer node allows the interaction to jump to any location in the configuration tree.

Node Characteristics frame

Options in this frame name the node, and establish whether or not it is active, logged, or tracked for reporting purposes.

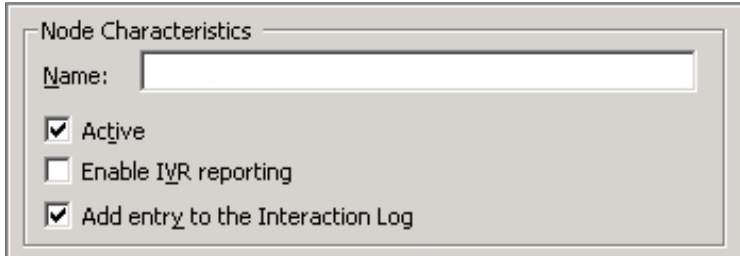

Name field

The label you enter here becomes the name of the node in the tree structure.

Active check box

By default, forms are "on", or "active", which means that Interaction Attendant will process them. If you uncheck a form's Active check box, the name of the node turns gray in the tree to indicate that the form is inactive. Interaction Attendant and its [handlers](#) will thereafter ignore the form and its children. Use this feature to save a configuration that you are testing. Inactive forms are invisible to callers. When a node is inactive, it appears grayed out in the tree view.

Enable IVR Reporting

This option determines whether or not reporting data will be collected when control passes through this node. Several IVR Reports summarize this information. IVR Reporting is *disabled* by default. Enable it to capture the date, time and duration of time that the call remained in the node and its children. This option is hidden when Attendant is connected to a server that does not have reporting installed. For more information about this feature, see [IVR Reporting Option](#).

Add entry to the Interaction log

When this option is enabled, information about this node is appended to the call's Interaction Log when the call enters this node. This helps track the path that a call took through Attendant. The Interaction Log is maintained for reporting purposes. See [View the Interaction Log](#) for details.

Transfer the call to this menu frame

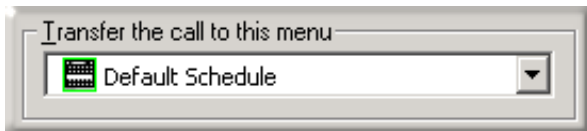

Transfer the call to this menu drop list

The node to which processing should be transferred.

Related Topics

- [Email Profiles](#)
- [Email Schedules](#)
- [Email Operations](#)

Email - Transfer to a Workgroup

This node transfers an email interaction to a workgroup. If the destination workgroup is an ACD workgroup, you can optionally select skills that the Agent handling the interaction must have to receive the Interaction. This node is sometimes called "Group Transfer", since it transfers an interaction to a workgroup queue.

Node Characteristics frame

Options in this frame name the node, and establish whether or not it is active, logged, or tracked for reporting purposes.

Name field

The label you enter here becomes the name of the node in the tree structure.

Active check box

By default, forms are "on", or "active", which means that Interaction Attendant will process them. If you uncheck a form's Active check box, the name of the node turns gray in the tree to indicate that the form is inactive. Interaction Attendant and its [handlers](#) will thereafter ignore the form and its children. Use this feature to save a configuration that you are testing. Inactive forms are invisible to callers. When a node is inactive, it appears grayed out in the tree view.

Enable IVR Reporting

This option determines whether or not reporting data will be collected when control passes through this node. Several IVR Reports summarize this information. IVR Reporting is *disabled* by default. Enable it to capture the date, time and duration of time that the call remained in the node and its children. This option is hidden when Attendant is connected to a server that does not have reporting installed. For more information about this feature, see [IVR Reporting Option](#).

Add entry to the Interaction log

When this option is enabled, information about this node is appended to the call's Interaction Log when the call enters this node. This helps track the path that a call took through Attendant. The Interaction Log is maintained for reporting purposes. See [View the Interaction Log](#) for details.

Workgroup / Attribute radio buttons

These options identify the workgroup or station group queue to which the call is transferred.

Workgroup radio button

This radio button enables the drop down list.

Workgroup drop down list

This drop down list allows you to select the name of any workgroup queue that is defined for the server. The email interaction will be transferred to the group you select.

Workgroup specified by interaction attribute list box

This option allows you to select a specific workgroup by the workgroup ID contained in the interaction attribute 'Eic_AttDynamicWorkgroupName' and defined for the server. This is particularly helpful in environments which contain a large number of workgroups, thereby making it cumbersome to select the appropriate workgroup. For example, you can organize workgroups according to area of expertise, such as web service calls, customer handler calls, etc., and assign names to the workgroups that help identify the specific skill. Then, you can place the workgroup name in the interaction attribute 'Eic_AttDynamicWorkgroupName' and use that attribute for a workgroup transfer operation..

Advanced Workgroup Settings and Threaded Email Options buttons

Use these buttons to specify advanced workgroup settings and to configure threaded email options.

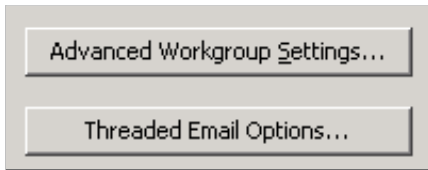

Advanced Workgroup Settings button

This button opens the [Advanced Workgroup Properties Dialog \(Email\)](#), so that you can set priority, needed agent skills, the length of time that the email should remain in the queue before timing out, and processing to perform if the interaction times out. This button is disabled for operator profiles.

Threaded Email Options button

This button opens the [Threaded Email Options dialog](#), where you can specify whether an email interaction is sent to either the first or the last workgroup that handled the email message, and how long it remains in the workgroup queue before it times out and returns to the workgroup queue specified in the Workgroup/Attribute section above. The Threaded Email Options button is disabled if conversation identifier (CID) generation has not been selected in Interaction Administrator and an Interaction Tracker license has not been enabled.

Related Topics

- [Advanced Workgroup Properties Dialog \(Email\)](#)
- [Threaded Email Options Dialog \(Email\)](#)

Configure a Selection Node

A Selection action branches on condition after evaluating one or more expression cases. This action is similar to a [Logical Transfer](#), but is easier to set up when multiple expression cases must be evaluated. Selection nodes are easier to understand because there are no jumps to other nodes in the tree view. The Selection action works like a C++ switch statement, or a Visual Basic Select Case statement, if you are familiar with programming concepts.

For example, a company which offers three levels of technical support (Bronze, Silver, or Gold) could store an interaction's support level in an attribute, and later use a Selection node to examine the value of that attribute to take different actions.

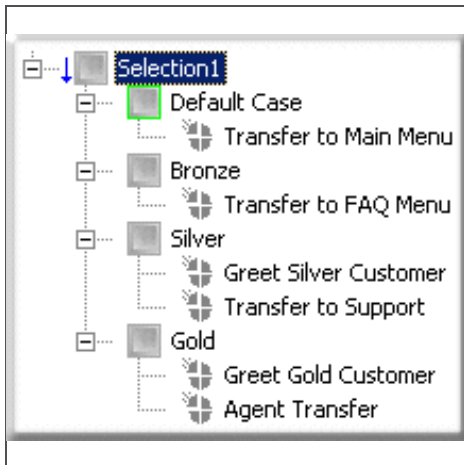
	<p>The figure at left shows Expression Case nodes below the Selection action and displays child operations to perform for each possible case. In this example:</p> <p>Default Case: If the value of the attribute is not Bronze, Silver, or Gold, the Default Case expression case is selected, which in this example transfers the interaction to a Main Menu.</p> <p>Bronze: An expression case was created to transfer Bronze interactions to a FAQ menu.</p> <p>Silver: An expression case was created to direct the system to send Silver interactions (in this example, calls) a customized greeting message on their way to the Support queue.</p> <p>Gold: An expression case was created to direct the system to transfer Gold interactions (in this example, calls) to an Agent's queue after first receiving their own custom greeting.</p>
---	--

Selection actions make it easy to set up multiple branches based upon evaluation of flexible expression criteria.

Configure a Selection Node

1. Add a **Selection** node. In the **Name** field, type a meaningful name for the selection action.
2. Click the **Digit** drop down list and select a number to assign to the selection action. This is the key that callers press to select the menu entry. When you assign a digit, the only available digits are those that are not already in use at this level of the tree. If you do not assign a digit, callers cannot invoke the operation directly.

Note: The **Digit** drop down list is not available for e-mail interactions, and does not appear in E-mail Configuration files.

3. Place a check mark in any **Node Characteristics** that apply:

Checkbox	Description
Active	By default, this field contains a check mark, which means the form is "on", or "active" and Interaction Attendant will process them. If you un-check a form's Active check box, the name of the form turns gray in the tree to indicate that the form is inactive. Interaction Attendant and its handlers will ignore the form and its children. Leave the box unchecked to save a configuration that you are testing. Inactive forms are unavailable to interactions
Default Action	At any given level in the tree structure, one node can be marked as the default action. The operation defined by the default node is performed if callers do not press a key within the timeout period specified by that menu. The icon for default forms has a green border in the tree structure. Any node below a menu or schedule can be marked as the default action , by checking the form's default action check box. Note: The Default Action check box is not available for e-mail interactions, and does not appear in E-mail Configuration files.
Enable IVR Reporting	This option determines whether or not reporting data will be collected when control passes through this node. Several IVR Reports summarize this information. IVR Reporting is <i>disabled</i> by default. Place a check mark in this box to capture the date, time and duration of time that the interaction remained in the node and its children. This option is hidden when Attendant is connected to a server that does not have reporting installed. For more information about this feature, see IVR Reporting Option .
Add entry to the Interaction log	When this option is enabled, information about this node is appended to the interaction's Interaction Log when the interaction enters this node. This helps track the path that an interaction took through Attendant. The Interaction Log is maintained for reporting purposes. See View the Interaction Log for details.
Configure Screen Recognition button	Select this button to configure words or phrases that can be associated with menu options. Callers can verbally indicate the options they want in the IVR instead of pressing a digit on the phone. You can enter multiple words and phrases for each menu item, just as callers may phrase the same request in different ways. For example, "transfer funds" or "funds transfer". See Add Speech Recognition keywords or phrases to Inbound Call Operations .

4. **For Inbound, Outbound, or Operator calls only**, set up the expression criteria:
 - a. Click **Create Expression Criteria** to set up the left hand of the expression, or what is evaluated. The [Expression Type Wizard](#) opens. You can create an expression using the following data types:
 - Data previously entered by the caller
 - Data about the current call
 - The current time
 - Data about a particular workgroup (ACD or Custom)
 - Data from a database
 - b. Select a data type. Then click **Next** or **Finish** based on the options available for the data type selected. You may be prompted to select or enter specific data. For example, if you select *Data about the current call*, you must click *Next* to specify the name of a call attribute (see the following figure). Conversely, if you select *The current time*, you can click *Finish* immediately since no additional information must be supplied.

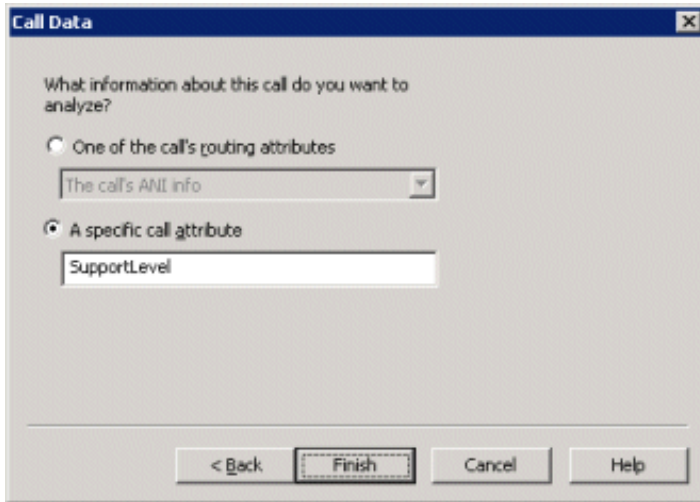

The Call Data dialog opens when you select Data about the current call.

Note: The resulting Expression Criteria will appear as read-only text. Note that the Selection node is in error until valid expression criteria is defined.

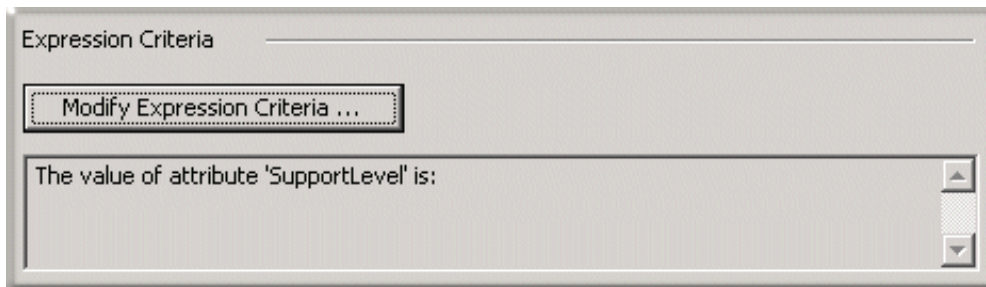

5. The next step is to add expression cases. For instructions, see [Configure an Expression Case](#).

Related Topics

- [Configure an Expression Case](#)

Configure an Expression Case

An Expression Case is a node that contains defined conditional processing for a parent [Selection](#) action. Before you can define case nodes, you must first [Configure a Selection Node](#).

In the tree view, **Expression Cases** appear as nodes underneath the **Selection** action. This makes it easy to see all of the available paths that can be taken. In addition, a **Default Case** appears below the selection node. If all other expression cases evaluate false, routing will take the path below that case. Each case behaves like a multi-action container where actions can be placed underneath, and they are processed in top down order like that of an e-mail profile. Whenever a new selection action is added to the tree view, a default case is added underneath it as well.

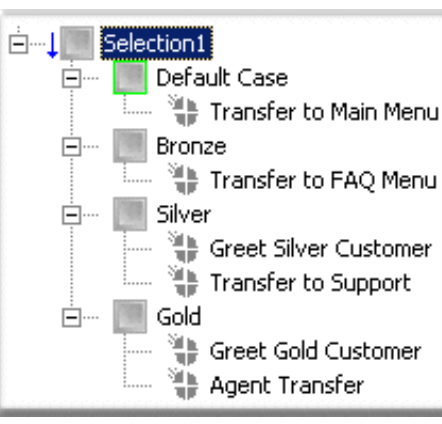
	<p>The figure at left shows Expression Case nodes below the Selection action and displays child operations to perform for each possible case. In this example:</p> <p>Default Case: If the value of the attribute is not Bronze, Silver, or Gold, the Default Case expression case is selected, which in this example transfers the interaction to a Main Menu.</p> <p>Bronze: An expression case was created to transfer Bronze interactions to a FAQ menu.</p> <p>Silver: An expression case was created to direct the system to send Silver interactions (in this example, calls) a customized greeting message on their way to the Support queue.</p> <p>Gold: An expression case was created to direct the system to transfer Gold interactions (in this example, calls) to an Agent's queue after first receiving their own custom greeting.</p>
---	--

Configure an Expression Case

1. Set up a Selection node. For instructions, see [Configure a Selection Node](#).
2. Select the newly created selection node and under Expression Cases click Add. The Case Edit dialog opens.

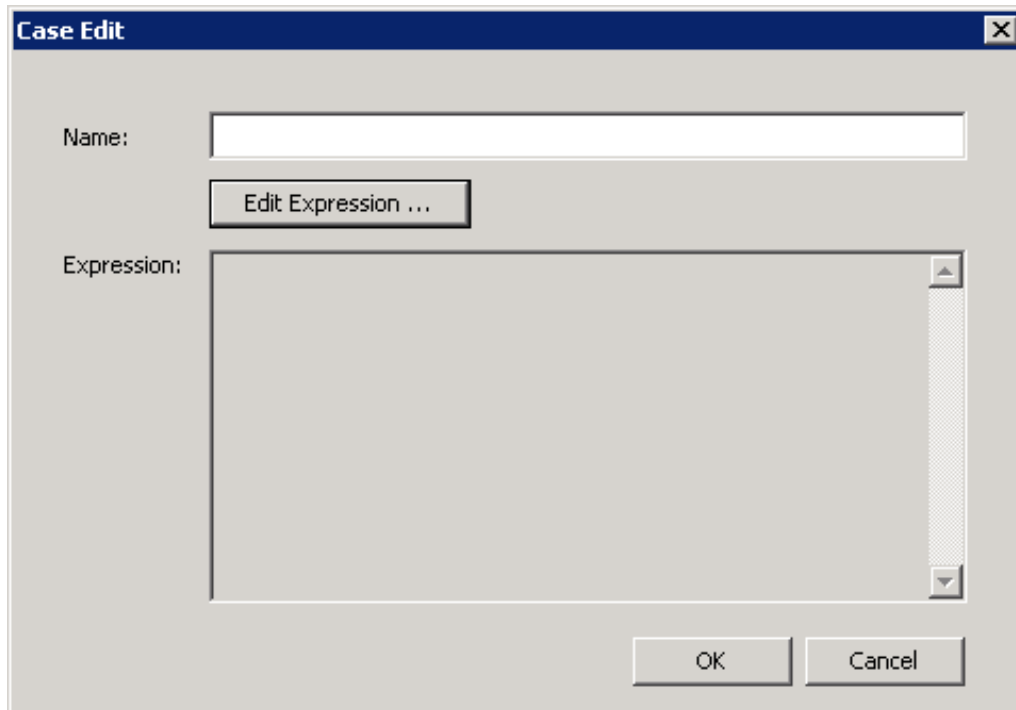

3. Set up the Expression Case:
 - To set up an expression case for **Inbound, Outbound, or Operator Configurations**:
 - In the **Name** field, type a meaningful name for the expression case and then click **Edit Expression**. The **Call Properties** dialog opens.

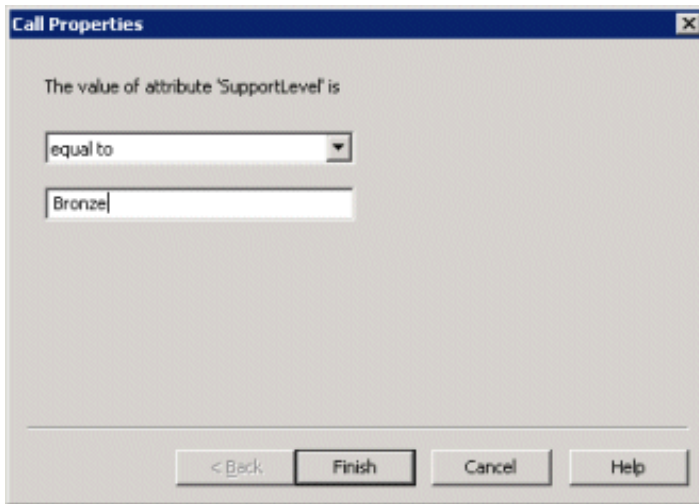

- Click the **The value of attribute '[attribute name]'** drop down list and select one of the following operators:
 - a. Greater than
 - b. Greater than or equal to
 - c. Equal to
 - d. Less than or equal to
 - e. Less than
 - f. Before (applies to data/time criteria only)
 - g. After (applies to data/time criteria only)
- In the field below the **The value of attribute '[attribute name]'** drop down list, enter a value against which to compare the expression criteria (in the example above: Bronze, Silver, or Gold). Click **Finish**.
- To set up an expression case for **E-mail Configurations**:
 - In the **Name** field, type a meaningful name for the expression case and then click **Edit Expression**. The **Email Conditions** dialog opens.

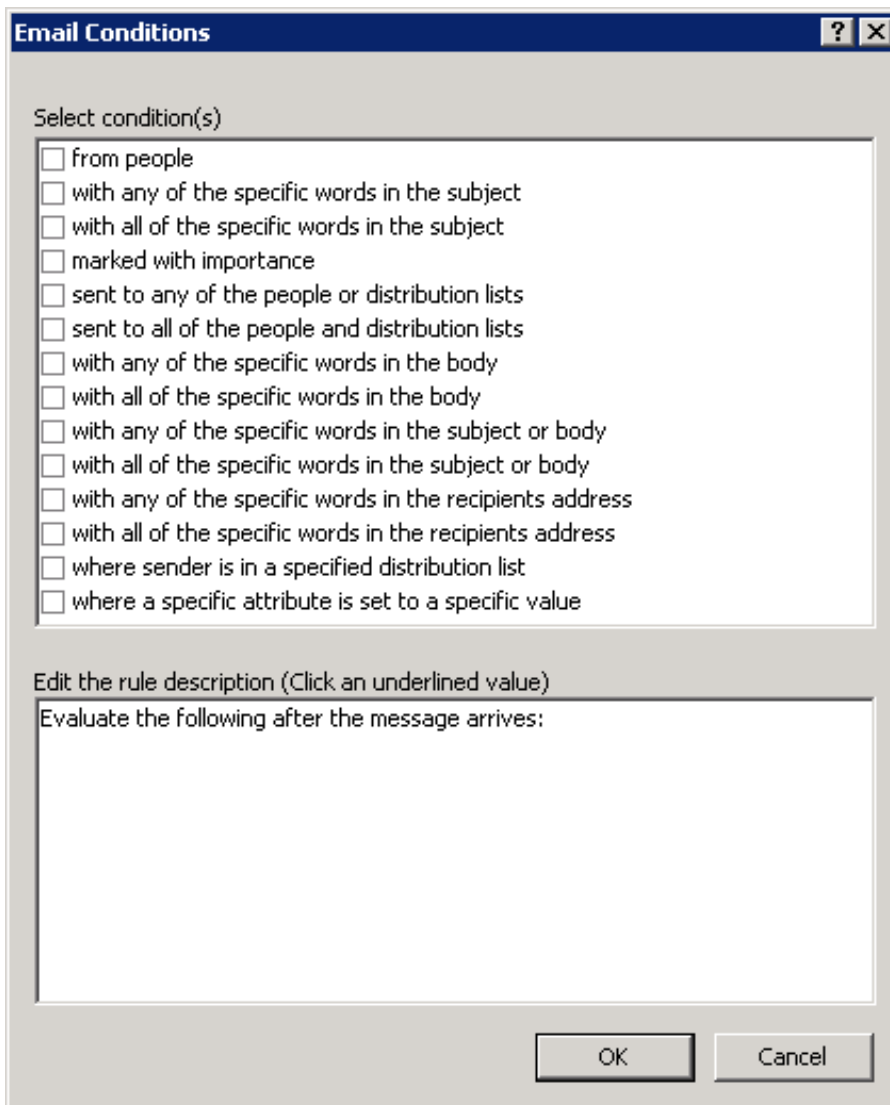

- In the **Select condition(s)** area, select one or more criteria to apply to the expression.
- In the **Edit the rule description (Click an underlined value)** area, click the hyperlink(s) associated with each rule to specify how the e-mail is evaluated upon arrival.

Note: The next dialog box to appear will differ, depending on the criteria you select. For example, if you select the **marked with importance** condition check box, "**and marked with [specific importance](#)**" appears in the **Edit the rule description** area, and the word "[specific](#)" contains a hyperlink. When you click the [specific](#) hyperlink, the **Importance Level** dialog opens, and you can specify the degree of importance to place on the e-mail.

- Configure each rule description and then click **OK** to close the **Email Conditions** dialog.
4. Click **OK** to close the **Case Edit** dialog.
 5. To define additional cases, click the **Selection** node, and then click **Add**. You can only create case nodes by clicking **Add** on the selection node form view. Interaction Attendant does not contain a toolbar or menu item for adding case nodes.
 6. Select an expression case and use the toolbar or Insert menu to **add an operation node** that determines what action each branch should take if an interaction meets the case criteria. Repeat this procedure for each expression case. In the following

example, Play Audio, Menu Transfer, and Agent Transfer nodes were added.

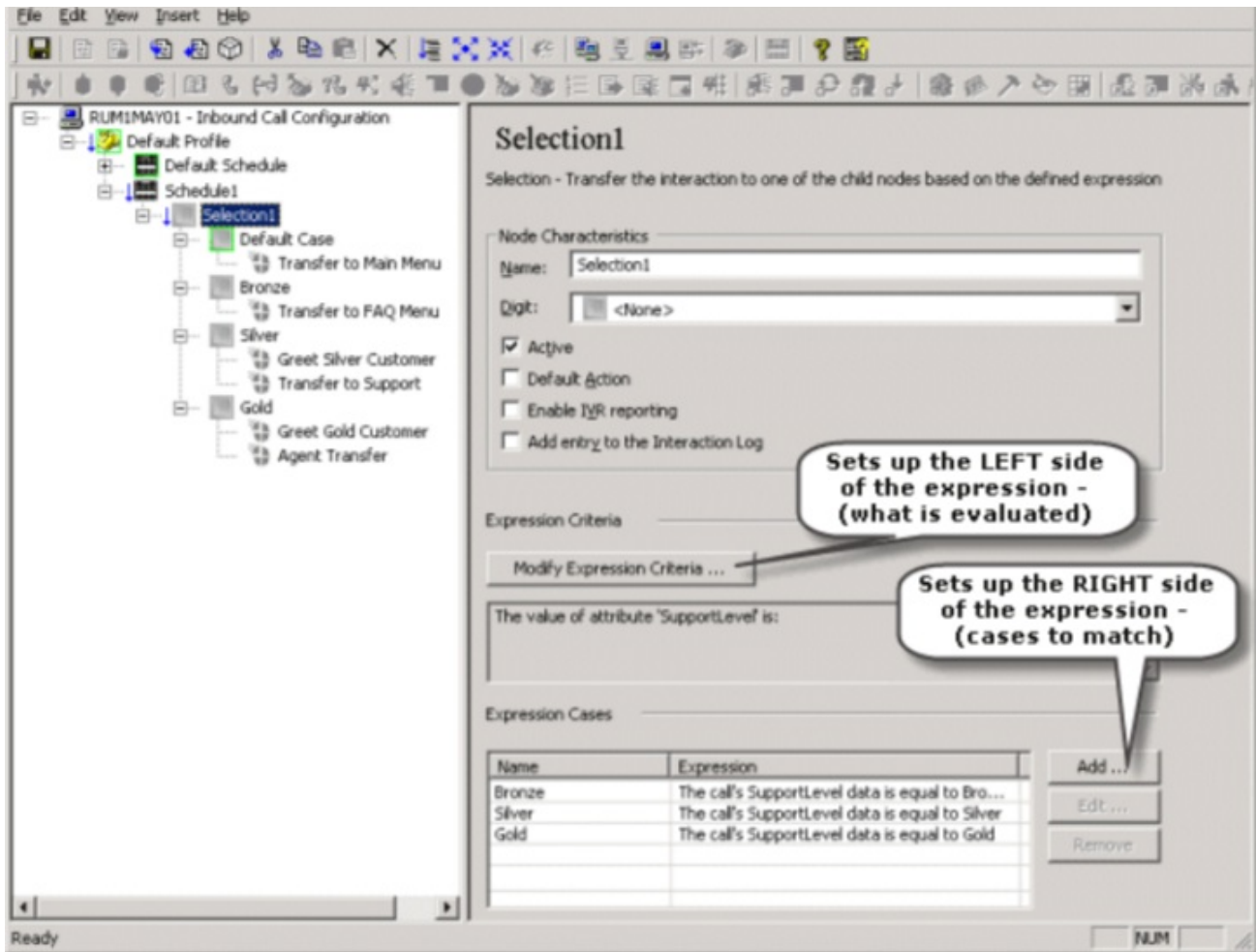

7. Place a check mark in any Node Characteristics that apply:

Checkbox	Description
Active	By default, this field contains a check mark, which means the form is "on", or "active" and Interaction Attendant will process them. If you un-check a form's Active check box, the name of the form turns gray in the tree to indicate that the form is inactive. Interaction Attendant and its handlers will ignore the form and its children. Leave the box unchecked to save a configuration that you are testing. Inactive forms are unavailable to interactions
Default Action	At any given level in the tree structure, one node can be marked as the default action. The operation defined by the default node is performed if callers do not press a key within the timeout period specified by that menu. The icon for default forms has a green border in the tree structure. Any node below a menu or schedule can be marked as the default action , by checking the form's default action check box. Note: The Default Action check box is not available for e-mail interactions, and does not appear in E-mail Configuration files.
Enable IVR Reporting	This option determines whether or not reporting data will be collected when control passes through this node. Several IVR Reports summarize this information. IVR Reporting is <i>disabled</i> by default. Place a check mark in this box to capture the date, time and duration of time that the interaction remained in the node and its children. This option is hidden when Attendant is connected to a server that does not have reporting installed. For more information about this feature, see IVR Reporting Option .
Add entry to the Interaction log	When this option is enabled, information about this node is appended to the interaction's Interaction Log when the interaction enters this node. This helps track the path that an interaction took through Attendant. The Interaction Log is maintained for reporting purposes. See View the Interaction Log for details.
Configure Screen Recognition button	Select this button to configure words or phrases that can be associated with menu options. Callers can verbally indicate the options they want in the IVR instead of pressing a digit on the phone. You can enter multiple words and phrases for each menu item, just as callers may phrase the same request in different ways. For example, "transfer funds" or "funds transfer". See Working with Speech Recognition for details.

Related Topics

- [Configure a Selection Node](#)

Dialogs

This section explains dialogs that you may encounter while working in Attendant.

- [Profiles](#)
- [Schedules](#)
- [Operations](#)

Advanced Workgroup Properties Dialog (Calls)

This dialog appears when the *Advanced Workgroup Settings* button on a [Group Transfer](#) node is pressed. It sets interaction priority, needed skills, the length of time the interaction should remain in the queue before timing out, and processing to perform when the interaction times out.

Properties tab

The Properties tab allows you to assign a priority to the interaction (0= lowest, 1000 = highest) by either setting a static value or by using the value contained in the 'Eic_AttDynamicWorkgroupPriority' interaction attribute.

You can also request that agents who handle the interaction have particular skills, and you can further narrow the eligible agents by routing interactions to agents who have the skill set as defined in the interaction attribute 'Eic_AttDynamicWorkgroupSkills'. Simply check the name of the required skill(s) that appear in the list.

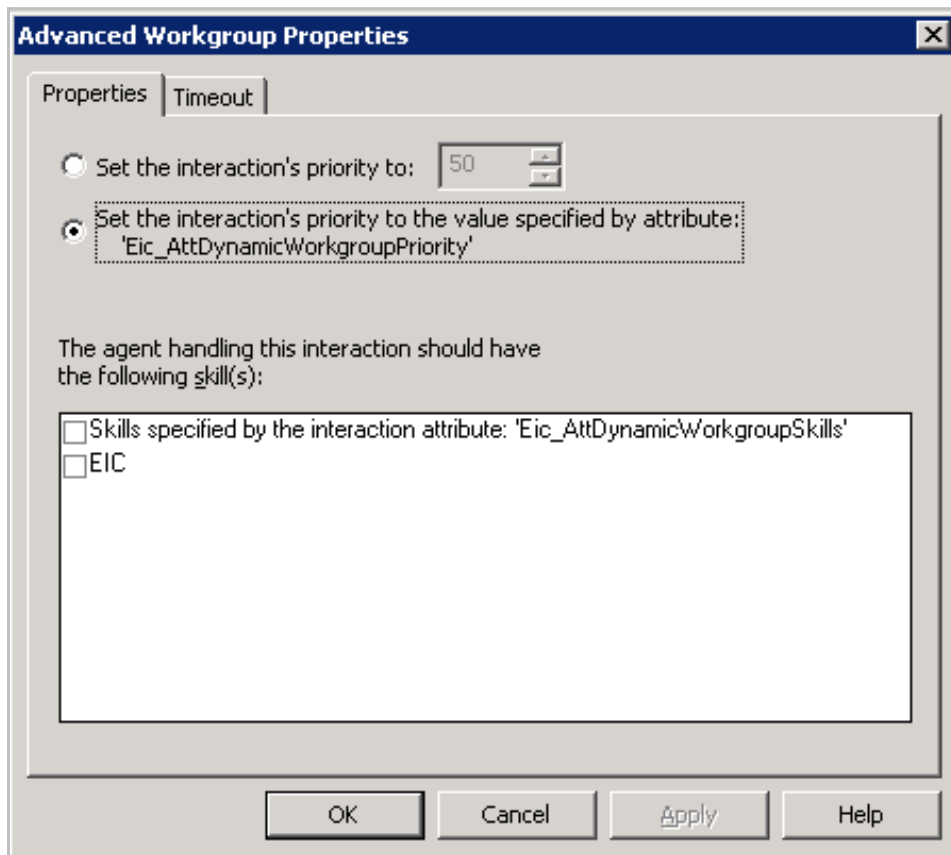

Set the interaction's priority to...

Assigns the priority value of the interaction to any integer between 0 and 1000.

Set the interaction's priority to the value specified by attribute...

Assigns the priority value for the interaction to the value specified in the interaction attribute 'Eic_AttdynamicWorkgroupPriority'.

The agent handling this interaction should have the following skill(s)

Displays a list of skills required for the agent who receives this call. Select the appropriate skill check box, or select the Skills specified by the interaction attribute "Eic_AttdynamicWorkgroupSkills" check box to route interactions to agents who are assigned to this interaction attribute.

Timeout tab

The settings on this tab determine the lifetime of interactions in the queue, and action that occurs on timeout if the interaction is not configured to stay in the queue until it is answered.

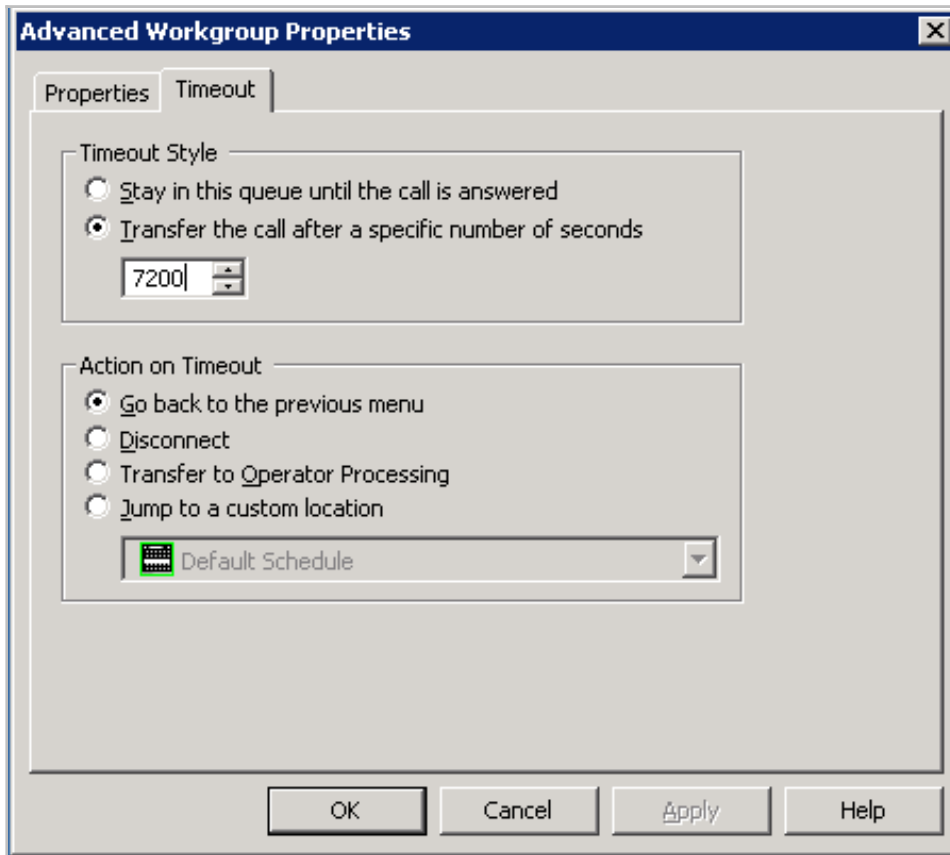

Timeout Style frame

These settings determine whether the interaction stays in the queue until it is answered, or is transferred out after a specified timeout period.

Stay in this queue until the call is answered

Select this option to keep the interaction in the queue until it is answered.

Transfer the call after a specific number of seconds

This option sets a maximum length of time in seconds that the interaction can remain in this queue before it is transferred out. You can specify any duration between 1 and 7200 seconds (two hours).

Action on Timeout frame

You have four flow-of-control options when calls time out:

Go back to the previous menu

Returns flow of control to the previous menu.

Disconnect

Hangs up the interaction when it times out.

Transfer to Operator Processing

Transfers the interaction for evaluation by operator profiles defined for this server.

Jump to a custom location

Transfers control to any profile, schedule, menu, or operation defined for the current server.

Related Topics

- [Email - Transfer to a Workgroup](#)

Advanced Workgroup Properties Dialog (Email)

This dialog appears when the *Advanced Workgroup Settings* button is pressed on the [Transfer to a Workgroup](#) node for an email interaction. This dialog allows the designer to set priority within the queue, needed agent skills, the length of time that the interaction should remain in the queue before timing out, and processing to perform after a time out.

Properties tab

The Properties tab allows you to assign a priority to the interaction (0= lowest, 1000 = highest) by either setting a static value or by using the value contained in the 'Eic_AttDynamicWorkgroupPriority' interaction attribute.

You can also request that agents who handle the interaction have particular skills, and you can further narrow the eligible agents by routing interactions to agents who have the skill set as defined in the interaction attribute 'Eic_AttDynamicWorkgroupSkills'. Simply check the name of the required skill(s) that appear in the list.

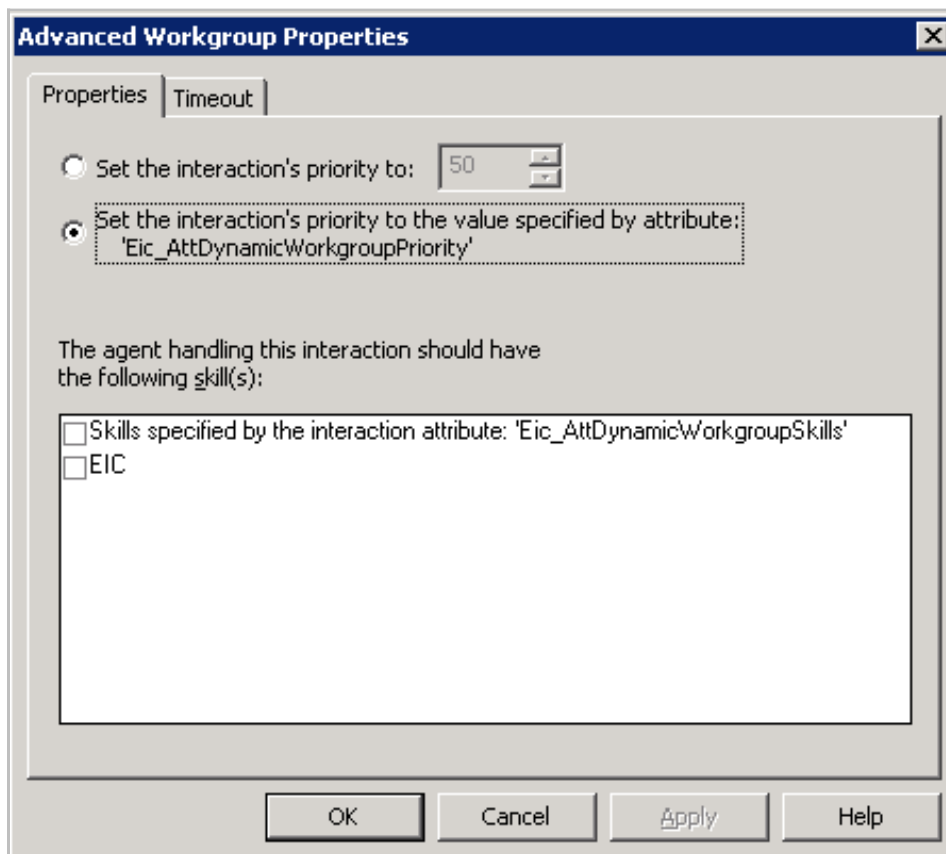

Set the interaction's priority to...

Assigns the priority value of the interaction to any integer between 0 and 1000.

Set the interaction's priority to the value specified by attribute...

Assigns the priority value for the interaction to the value specified in the interaction attribute 'Eic_AttDynamicWorkgroupPriority'.

The agent handling this interaction should have the following skill(s)

Displays a list of skills required for the agent who receives this call. Select the appropriate skill check box, or select the Skills specified by the interaction attribute "Eic_AttDynamicWorkgroupSkills" check box to route interactions to agents who are assigned to this interaction attribute.

Timeout tab

The settings on this tab determine the lifetime of interactions in the queue, and action that occurs on timeout if the interaction is not configured to stay in the queue until it is answered.

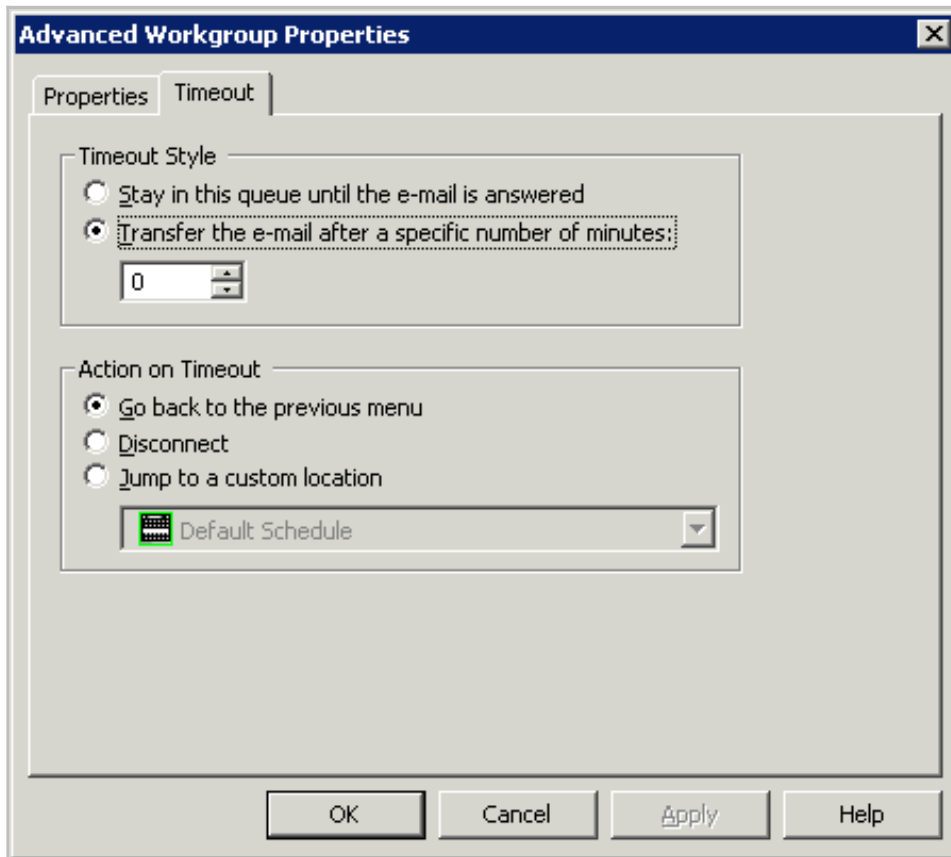

Timeout Style frame

These settings determine whether the interaction stays in the queue until it is answered, or is transferred out after a specified timeout period.

Stay in this queue until the e-mail is answered

Select this option to keep the interaction in the queue until it is answered.

Transfer the e-mail after a specific number of seconds

This option sets a maximum length of time in seconds that the interaction can remain in this queue before it is transferred out. You can specify any duration between 1 and 7200 seconds (two hours).

Action on Timeout frame

You have the following flow-of-control options when email messages time out:

Go back to the previous menu

Returns flow of control to the previous menu.

Disconnect

Hangs up the interaction when it times out.

Jump to a custom location

Transfers control to any profile, schedule, menu, or operation defined for the current server.

Related Topics

- [Email - Transfer to a Workgroup](#)

Attendant In Use Dialog

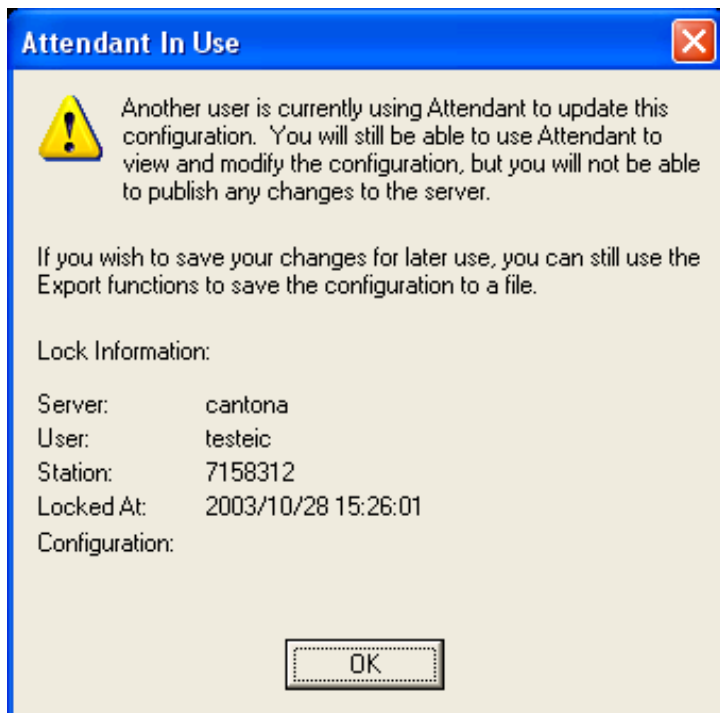

This dialog appears when another person is editing the configuration of the server you are connected to. When you press *OK* to dismiss the dialog, you can use Attendant to view and modify the configuration, but it will not allow you to publish changes to the server.

To save your edits, you must [backup export](#) the configuration to a disk file, and [import](#) it later when no one else is editing. Since importing a configuration will overwrite all changes that the other person is making, a gentler and kinder approach might be to contact the person who is editing the configuration to find out when they will be done.

In rare situations it may be desirable to overwrite this lock. For example, a power outage might have left a lock in place. If you set your PC clock ahead 24 hours and restart Attendant, it will display the [Stale Lock Dialog](#), which provides the option to overwrite the lock.

Server

The name of the server whose configuration is locked.

User

The login ID of the person who is currently editing the configuration.

Station

The station name or telephone number where the user is working from.

OK button

Closes the dialog. Thereafter you may view, edit, export, but not publish configuration data for the server.

Related Topics

- [Connect to a Server](#)
- [Manage Configuration Files](#)

Audio File Details Dialog

The *Audio File Details* dialog displays the language, playback duration, and encoding format of wave audio files for a prompt. This dialog appears when the *Details* button is pressed from a set of [embedded audio controls](#).

Prompt Format

Customers who use Interaction Attendant may choose to have their prompts recorded by a third party and need to know our native prompt format, which is: CCITT u-law, 8kHz, 8 bit, Mono for best results.

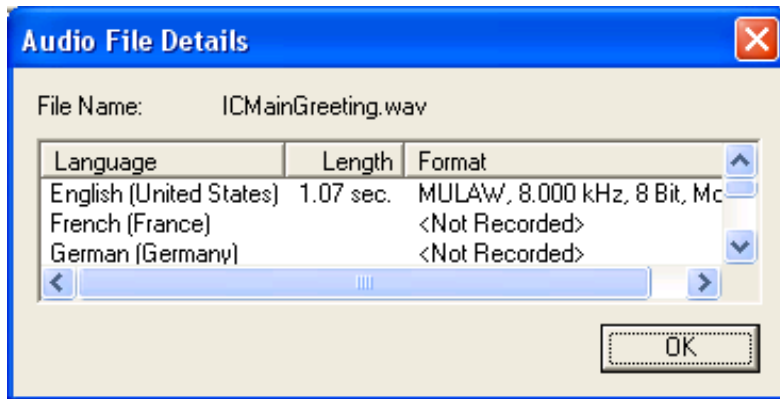

The Audio File Details dialog.

File Name

The name of the prompt file that selected by the user.

Language

This column lists languages that the prompt was (or could be) recorded in.

Length

The duration of the prompt in seconds.

Format

The encoding format of the wave audio file.

OK button

Closes the *Audio File Details* dialog.

Related Topics

- [Manage Voice Prompts](#)
- [Using Embedded Audio Controls](#)

Audio Prompt Name Dialog

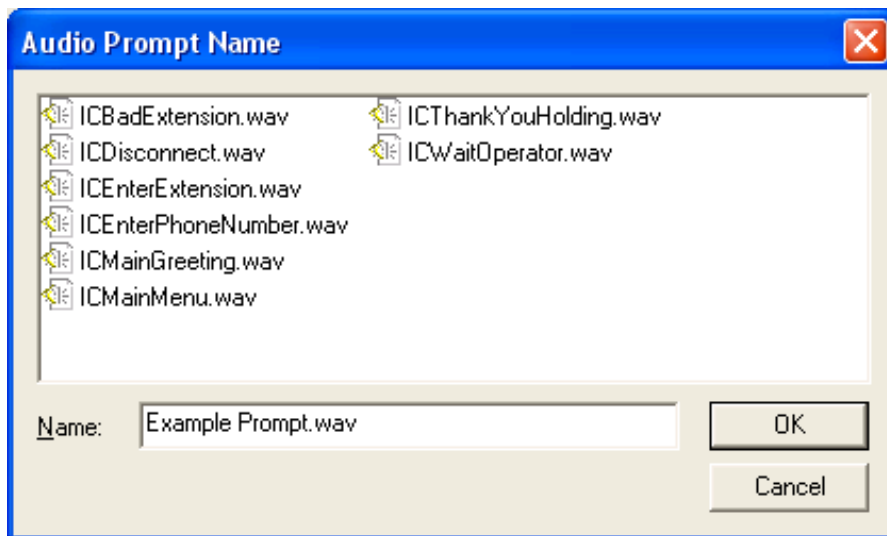

Attendant displays the *Audio Prompt Name* dialog when *Record* is pressed to create a new voice prompt file. Use this dialog to enter a descriptive name for the new prompt. It displays a list of wave audio files found in the default language directory under the AttendantWaves share on the server.

If you type or select the name of an existing file, the default language version of the file will be replaced by your new recording. This does not replace alternate language versions of the file that might exist.

OK button

Establishes the filename that you selected or typed and closes the dialog so that recording can begin.

Cancel button

Closes the dialog and cancels recording of the prompt.

Related Topics

- [Manage Voice Prompts](#)
- [Using Embedded Audio Controls](#)

Call Processing Style Dialog

Call profile forms provide a *Call Processing Style* button. When pushed, it displays the dialog shown below. It determines whether calls are directed to a menu (*Auto Attendant Processing*) or to a User, Station, Workgroup queue, or operator profile (*Direct to Queue Processing*).

Auto Attendant Processing is used by default—inbound calls are directed to the menu attached to the best matching [schedule](#). In other words, *Call Processing Style* determines whether calls are directed to:

- A menu attached to a schedule in this profile. This is the default call processing behavior.
- A user, station, or workgroup queue.
- An operator profile.

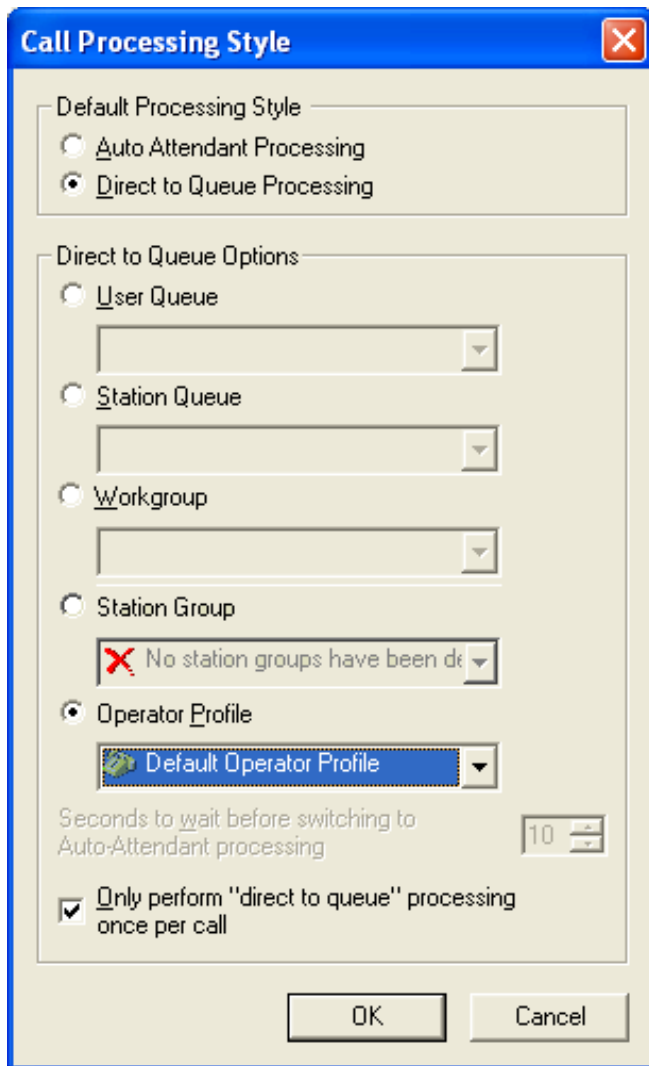

Default Processing Style frame

These options select the call processing style that will be used by default. Inbound calls will be processed using *Auto Attendant Processing* or *Direct to Queue Processing*.

Auto Attendant Processing

Auto Attendant Processing is enabled by default, so that calls are directed to a menu.

Direct to Queue Options

When this option is selected, the call is transferred to a User queue, Station queue, Workgroup queue, Station Group, or to an Operator profile.

Seconds to wait before switching to Auto-Attendant Processing

It specifies how long (in seconds) the call alerts in the following queues before processing returns to the auto-attendant:

- User
- Station
- Station group. A station group with a sequential setting alerts each station sequentially for the number of seconds indicated.

The call will be processed using a profile that you have set up for Auto-Attendant processing. If that profile does not exist, the default profile is used.

Note: This option does not apply to a workgroup queue. The time configured in the workgroup determines the alert time.

Only perform "direct to queue processing" once per call check box

If this check box is selected, a call will only follow the direct-to-queue processing the first time the call enters the system. If it winds up back in that profile again later, it won't ring the queue. If the check box is cleared, calls will follow the direct-to-queue instructions each time they pass through the profile.

Related Topics

- [Profiles](#)

Caller Data Entry Error Handling Options Dialog

The dialog box is titled "Caller Data Entry Error Handling Options" and has a close button (X) in the top right corner. It is divided into two main sections: "Re-prompt the Caller" and "Error Handling".

Re-prompt the Caller

- "Seconds to wait (between digits) before timing out:" is a spin control set to 3.
- "File to play to re-prompt the caller" is a dropdown menu currently showing "<None>". To its right is a "Preview:" section with play, stop, and volume control buttons.
- Below the dropdown are three buttons: "Browse...", "Record..." (with a dropdown arrow), and "Details...".
- "Number of times to re-prompt the caller:" is a spin control set to 3.

Error Handling

- There are two radio buttons:
 - The first is selected and labeled "Use the default error handler for this schedule".
 - The second is labeled "Jump to a custom location".
- Below the radio buttons is an empty text box with a dropdown arrow on the right.

At the bottom of the dialog are "OK" and "Cancel" buttons.

This dialog appears when the *Advanced Error Handling* button is pressed from a [Caller Data Entry](#) form. It defines optional error handling that works in addition to the error handling provided by a Schedule form.

Use this dialog to define the maximum length of time that Interaction Attendant should wait for caller data entry keystrokes before timing out and re-prompting the caller to start over. It also establishes the maximum number of times that the prompt will be repeated before control is passed to the Schedule's error handler, or to a [profile](#), [schedule](#), [menu](#), or [operation](#) defined for the current server.

Re-prompt the Caller

Seconds to wait (between digits) before timing out spin control

This control sets the maximum amount of time that Interaction Attendant will wait between digit presses. There is an initial timeout of 20 seconds if no digits are pressed.

If a user presses the key specified in the Digit list box, he or she has a predetermined amount of time to enter subsequent numbers before the system times out. The system also times out after a set period if a user enters less than the specified number of digits set in the End of Input Condition frame and does not enter a terminating character. Interaction Attendant will wait twice the set timeout value to receive the first digit and waits the exact timeout value for all subsequent digits. For example, if the timeout value

is set to 3 seconds, the system will wait 6 seconds to receive the first digit, and will wait three seconds to receive each subsequent digit.

If Speech Recognition is enabled on the Caller Data Entry node, Interaction Attendant will wait four times the set timeout value to receive the first digit and waits the exact timeout value for all subsequent digits. If Speech Recognition is enabled, you can use the **Reco Input Timeout Multiplier** server parameter to set a multiplier other than four. If advanced customization is required, you can add customization at the beginning of the CustomIntAttVoiceMenuInput handler.

File to play to re-prompt the caller ([embedded audio controls](#))

These controls manage the voice prompt played if users are re-prompted to enter digits. See [Manage Voice Prompts](#) for information about voice prompts.

Number of times to re-prompt the caller spin control

This spin control determines the number of times that the prompt will be repeated before control is passed to Error Handling. If this value is set to zero, Attendant does not re-prompt, so it is good practice to set this value to 1 or higher.

Error Handling

Error Handling options execute when a timeout occurs after the user has been re-prompted the maximum number of times.

Use the default error handler for this schedule

Passes control to error handling provided by the Schedule form that this caller data entry node is attached to.

Jump to a custom location

Passes control to the any [profile](#), [schedule](#), [menu](#), or [operation](#) that is defined for the current server.

Column Information Dialog

This dialog defines the data to insert or update in a database. You must specify the column (field) name to update, and the data that it will contain.

Column Name field

Enter the exact name of the field whose data will be inserted or updated in the database. If you don't know the field names that defined in the database, contact your database administrator, or the CIC system administrator. Column names are case-sensitive.

Column data frame

This frame contains options that define the data that will be inserted or updated in the database.

This string value field

Select this option to assign alphanumeric text to the column.

This numeric value field

Select this option to assign numeric digits to the column. Do not enter alphabetic characters, such as commas or dashes, in this field.

This boolean value

Select this option to assign a Boolean (True or False) value to the column.

This call attribute

Assigns the call attribute that you select to the database column. The choices are:

- ANI—the caller's telephone number.
- Caller ID—the caller's name.
- DNIS—the telephone number that was dialed.
- Interaction ID Key—a unique ID number that identifies a call. This key is always unique, while Call ID number may not be.
- Line Name—the CIC line name that the call came in on.

Data retrieved by the DB query at node

This option allows you to select any [DB Query](#) operation that is defined for the current server in a combo box. The results of that query will be assigned to the field. The combo box is empty unless the server configuration contains at least one DB Query node.

The value entered by the user at

This option assigns the value entered by the caller to the column. The list box is empty unless the server configuration contains at least one [Caller Data Entry](#) node.

The current date

Assigns the current date, based upon the CIC server clock, to the column in (YYYY-MM-DD format).

This date

Assigns the date you select (using a popup calendar control) to the column.

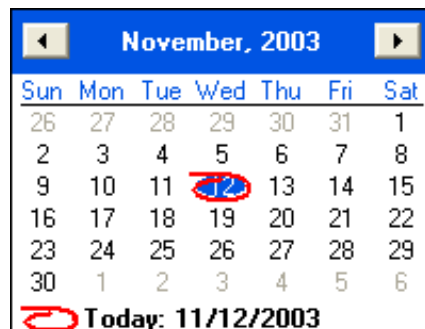

Current date and time

Assigns the current date and time to the column, based upon the CIC server clock, in ISO timestamp format:

YYYY-MM-DD HH:MM:SS

This date and time

Assign the date and time of day that you select using spin controls.

Ok button

Saves the selections that you have made and closes the dialog.

Cancel button

Closes the dialog without saving selections.

Related Topics

- [Database Operations](#)
- [Database Insert](#)
- [Database Update](#)

DB Record Selection Dialog

Several database operations provide a *Record Selection* button that opens the *Database Record Selection* dialog shown below. This dialog constructs the WHERE clause of a SQL query. To use Interaction Attendant, no knowledge of SQL is required. However, you do need to understand the layout of your database, so that you can use this dialog to define criteria that Attendant will use to select database records.

Update the record(s) that match the following criteria:

Column Name:

Contains data which (is)

greater than

This string value

This numeric value

This boolean value

This call attribute

The data retrieved by the DB query at node

The value entered by the user at

The current date

This date

The current date and time

This date and time

OK Cancel

Column Name field

Enter the exact name of the field that you wish to base the query on. If you don't know the field names that defined in the database, contact your database administrator, or the CIC system administrator. Column names are case sensitive.

Contains data which is combo box

This combo box allows you to select the comparison operator that will be used to compare *Column name* to some value that you select later. The comparison operations are:

- greater than
- greater than or equal to
- equal to
- not equal to

- less than or equal to
- less than
- contains
- starts with
- ends with

The last three logical operators deserve special mention—"contains", "starts with", and "ends with" are new in Attendant 2.4. They provide the functionality of SQL's "LIKE" operator, but without requiring any knowledge of SQL.

The value radio buttons allow you to compare the field identified by *Column name* to different types of values:

This string value

Compares the value specified in *Column Name* to any string value that you enter in this field. Column names are case-sensitive.

This numeric value

Compares the value specified in *Column Name* to any number that you enter in this field.

This boolean value

Compares the value specified in *Column Name* to the Boolean value (True or False) that you select from this combo box.

This call attribute

Compares the value specified in *Column Name* to the call attribute that you select from this combo box, or enter manually. The default attributes are: ANI, Caller ID, DNIS, Interaction ID Key, and Line Name. You can type the name of any custom attribute and use its value for database record selection. For more information about attributes, refer to the *Interaction Attributes Technical Reference*. You'll find that in the *System APIs* section of the master library on your CIC server.

Data retrieved by the DB query at node

This option allows you to compare the value specified by *Column Name* to information returned by a query from another node. The combo box is empty unless the server configuration contains at least one [Database query](#) form.

The value entered by the user at

This option compares the column identified by *Column Name* to a string of data collected by a [caller data entry](#) operation. Be careful using this option. It can potentially allow users to delete records based upon a wide range of selection criteria.

The current date

Compares the value specified in *Column Name* to the current date, using YYYY-MM-DD format.

This date

Compares the value specified in *Column Name* to the date you select in a popup calendar control.

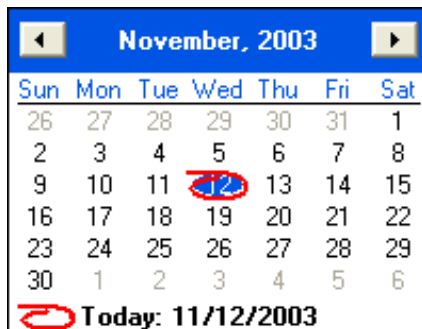

Current date and time

Compares the value specified in *Column Name* to the current date and time.

This date and time

Compares the value specified in *Column Name* to the date and time you select in using spin controls.

Ok button

The OK button applies the selections that you have made to build a query, and closes the dialog.

Cancel button

Press this button to close the dialog without building a new query.

Related Topics

- [Database Operations](#)

Default Error Handler Dialog (Calls)

This dialog appears when the *Schedule Error Handling* button is pressed from a [Call ScheduleXID_SCHEDULES](#) node. It sets up error handling to trap errors that occur when menus are processed. Specifically, it defines error processing that occurs:

- When errors are detected during the execution of a menu operation.
- When a greeting message on a schedule form has been played the maximum number of times without a valid response from the user.
- When the user presses a key that is invalid for the menu. For example, if the user is expected to press keys 1, 2, or 3, and the user presses 4, Attendant ignores the invalid digit and continues to play menu audio. If the desired behavior for a menu is to have an error message played for invalid key presses, an audio node can be set up for all unused digits which can play the error message and then return the caller to the menu.
- The error handler can optionally play a message, before disconnecting or transferring the call to a queue or menu.

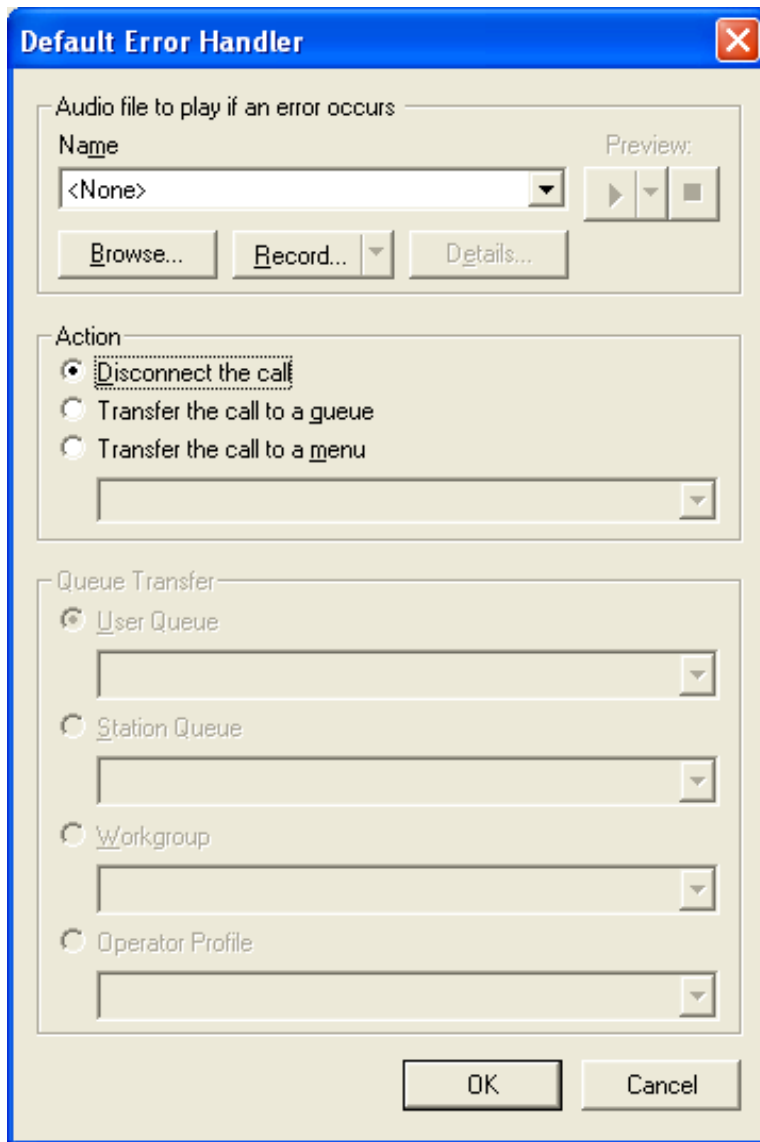

Audio File to play if an error occurs frame

These [embedded audio controls](#) manage the message that plays when an error occurs. See [manage voice prompts](#) to learn how to use these controls.

Action frame

Disconnect the call

Disconnects the call.

Transfer the call to a queue

Enables options in the Queue Transfer frame, to allow the call to be transferred to the User Queue, Station Queue, Workgroup Queue, or Operator Profile that you select.

Transfer the call to a menu

Transfers the call to the profile, schedule, or menu that you select.

Queue Transfer Frame

See Transfer the call to a queue above.

Pushbutton Options

OK button

Closes the dialog and puts your settings into effect.

Cancel button

Closes the dialog without modifying existing error handling settings.

Related Topics

- [Default Error Handler Dialog \(Emails\)](#)
- [Schedules](#)

Default Error Handler Dialog (Emails)

This dialog appears when the *Schedule Error Handling* button is pressed from an [Email ScheduleXID_SCHEDULES](#) node. It sets up error handling to trap errors that occur when menus are processed. Specifically, it defines error processing that occurs:

- When errors are detected during the execution of a menu operation.
- When a greeting message on a schedule form has been played the maximum number of times without a valid response from the user.
- When the user presses a key that is invalid for the menu. For example, if the user is expected to press keys 1, 2, or 3, and the user presses 4, Attendant ignores the invalid digit and continues to play menu audio. If the desired behavior for a menu is to have an error message played for invalid key presses, an audio node can be set up for all unused digits which can play the error message and then return the caller to the menu.
- You can set up this error handler to terminate the interaction, or transfer the Email message to a menu, user queue, or workgroup queue.



Action frame

Disconnect the e-mail

Discards the Email and terminates the interaction.

Transfer the e-mail to a queue

When this option is selected, drop lists in the *Queue Transfer* frame are enabled, so that you can transfer the Email message to the user- or workgroup queue of your choice.

Transfer the e-mail to a menu

Enables a drop list that allows you to select the menu that will receive the transferred Email.

Pushbuttons

OK button

Closes the dialog and puts your settings into effect.

Cancel button

Closes the dialog without modifying existing error handling settings.

Related Topics

- [Default Error Handler Dialog \(Calls\)](#)
- [Custom Email Schedule](#)
- [Schedules](#)

Email Formatting Help dialog

This dialog appears when the *Formatting Help* button is pressed on a [Custom Email Profile](#) form. It displays tips for entering email addresses and for using wildcards to filter a profile based upon "To", "Cc" and "From" fields in an email message. When you are finished, press *OK* to dismiss the dialog.

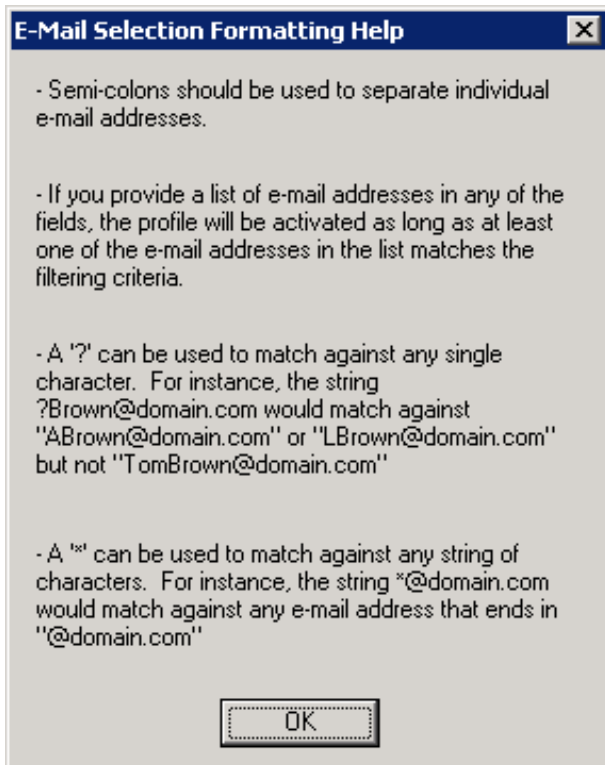

Related Topics

- [Custom Email Profile](#)
- [Profiles](#)

Export Wizard

This wizard appears when an [Export](#) or [Package](#) command is issued. It saves open call flow configurations as Attendant configuration (*.att) files, or the selected portion of the open call flow as an Attendant Package file (*.atp). The wizard prompts you to select the amount of server-specific information to include in the export file. This determines whether the file can be used as a server-specific backup, portable "full" configuration, or as an application template.

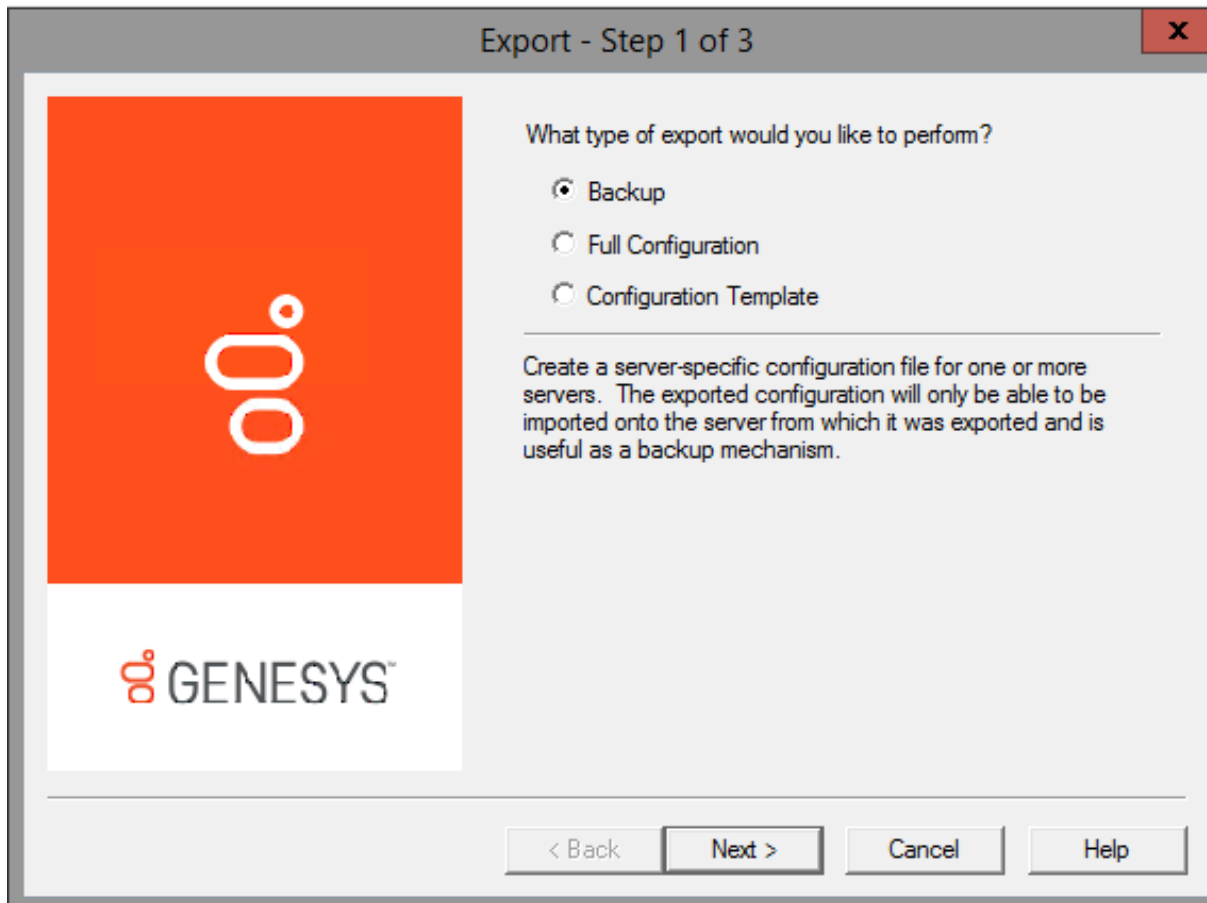

1. The first step is to choose the type of export to perform. Select the type of export to perform. Then press *Next* to proceed.

Backup

This option appears when a configuration is exported, but not when some portion of a call flow is packaged. Backup creates a server-specific configuration file that can be imported only by the server from which it was exported. This type of export saves server name, username, and password. You can backup more than one server at a time.

Full Configuration

For Exported Configurations: A full backup exports an exact copy of one server's configuration that can be loaded onto any other server. This saves the entire server configuration except for the server name and password. This makes it possible to move a configuration from a test server to a production server. The test server must be identical to the production server in terms of line names, workgroup names—everything except server name and password.

When the file is imported, Attendant prompts for a server to connect to, since the file does not contain any information about the origin of the data. Attendant analyzes the configuration and flags nodes that are in error (due to missing prompt files, differences in workgroup settings, etc.). For example, if a wave file was recorded on the test server and does not exist on the production server, Attendant would flag that node so that you can recreate the prompt on the production server.

For Packages: Creates a package file that contains an exact copy of the selected nodes' configuration. This package option is useful for moving part of a call flow from a test environment to a production server.

Configuration Template

For Exported Configurations: exports a generic configuration that can be loaded onto any server. This saves the general Attendant layout, but does not save server-specific information, such as workgroup names, user names, or audio files. The resulting file can be loaded onto a server and customized to match the destination server. This option is geared for partners and administrators who manage multiple sites. It exports a general configuration that does not require servers to be identically configured.

For example, a workgroup might be named Support on one system, and Customer Support on another. When the template is imported, Attendant recreates the call flow tree exactly, but any piece of information that could be server-specific (user names,

workgroup names, audio files, skills, etc.) is left blank. Incomplete nodes are flagged as errors, so that you can customize these nodes to match the destination server. Configuration templates allow developers to build custom solutions for customers, or to deploy an IVR interaction to many servers in an organization.

For Packages: creates a package file that contains a generic copy of the selected nodes' configuration. The package will contain the general Attendant layout of the selected nodes, but will not contain any server specific information such as workgroup or user names, or audio files. This option can be used to create a template call flow that can be loaded onto a server and then customized.

2. If you selected *Backup*, you can optionally back up more than one server at a time. Attendant prompts you to select servers to back up. It lists the names of connected servers, and the call flow type that is open for editing. Select server call flows to back up, and then press *Next* to proceed.

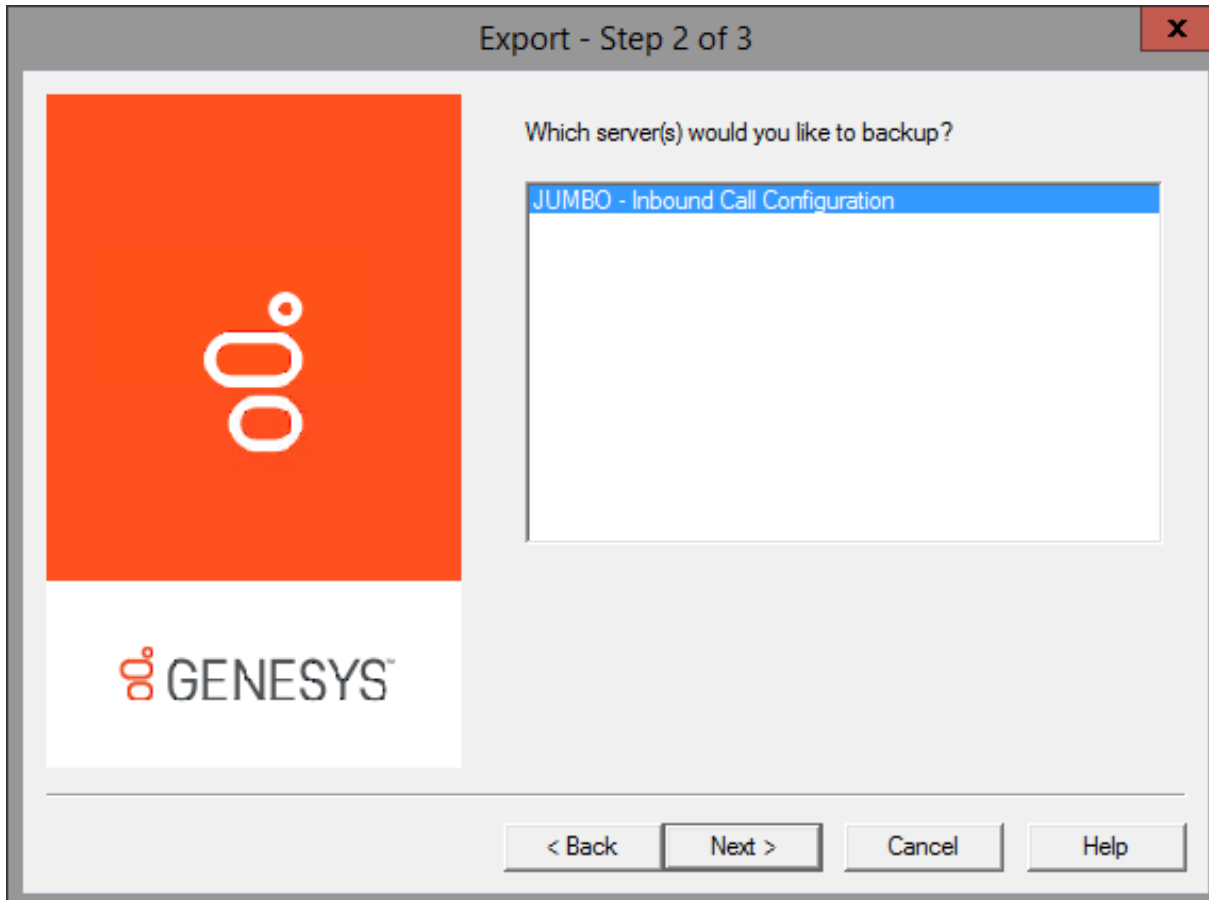

If you selected *Full Configuration* or *Configuration Template* back in step 1, Attendant prompts you to select a single call flow configuration. At this time, inbound, outbound, and operator call flows must be backed up separately for those export types. Select an item. Then press *Next* to proceed.

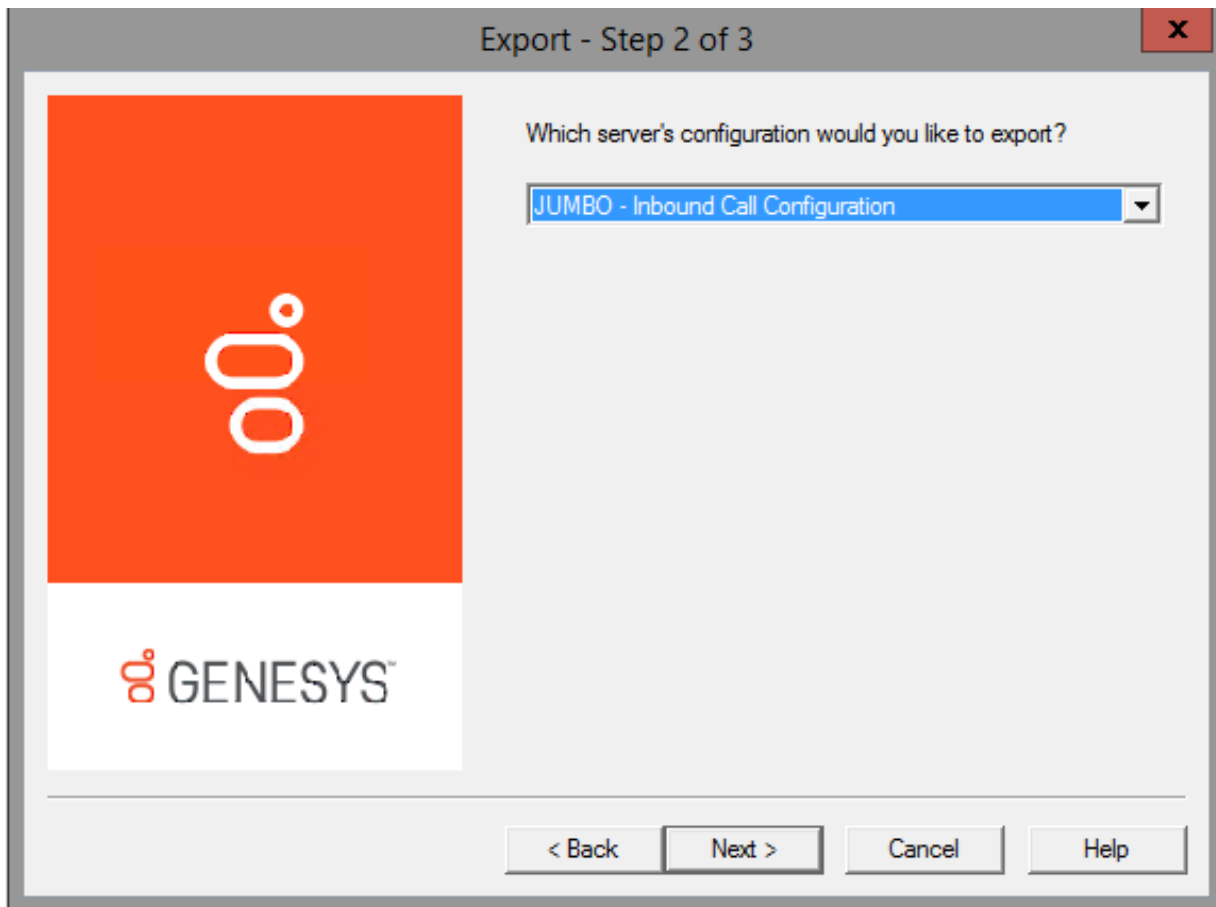

3. The last step is to set the destination path and filename of the export file. Select the destination path and type a meaningful file name. Attendant adds .att to the filename, to identify it as an Attendant configuration file.

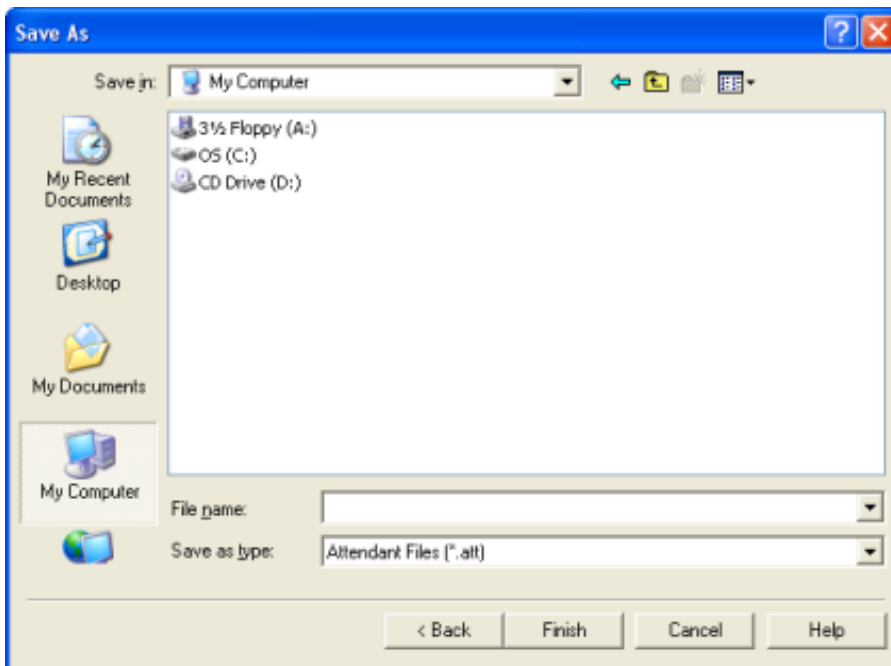

4. Press *Finish*. Attendant creates the export file for you, replacing existing files with the same name, if any exist. This file is in binary format and should not be edited manually.

Related Topics

- [Export a Configuration File](#)
- [Manage Configuration Files](#)

Email Rules Wizard

The Rules Wizard constructs a rule that allows an [Email Transfer](#) node to direct flow of control between two possible destinations, after examining the contents of an email message.

An email rule is a logical expression based upon the address, subject, or body text of an email message. This expression returns a Boolean (True or False) result. If the rule evaluates as True, then the Logical Transfer node will pass control to the "True" transfer location; if the rule is False, then the flow will jump to the alternate transfer location specified in the [Email Transfer](#) node.

To construct a rule:

1. Check a condition in the **Select Conditions** list. You can Ctrl-click to select multiple conditions. See [Condition Types](#) for information about these choices.

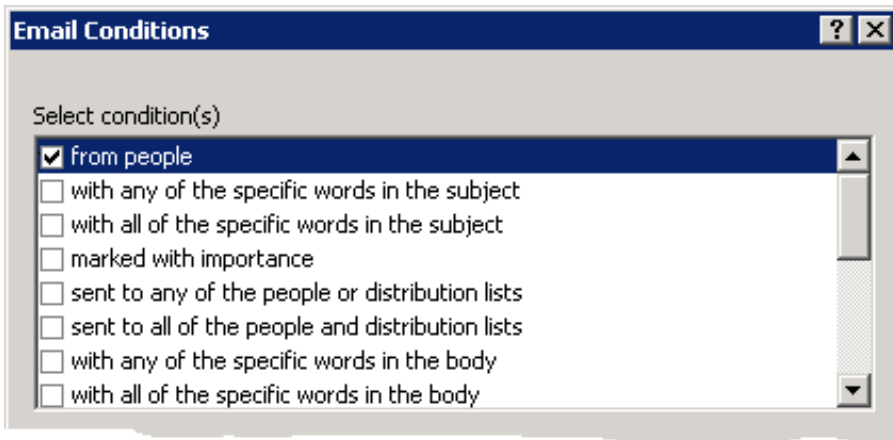

2. Next, click an underlined value in the **Edit the rule description** list.



3. Use the property editor that appears to set values for the rule to evaluate. Property editors are available for search words and phrases, for setting message priority (Importance), for distribution lists, and attributes.

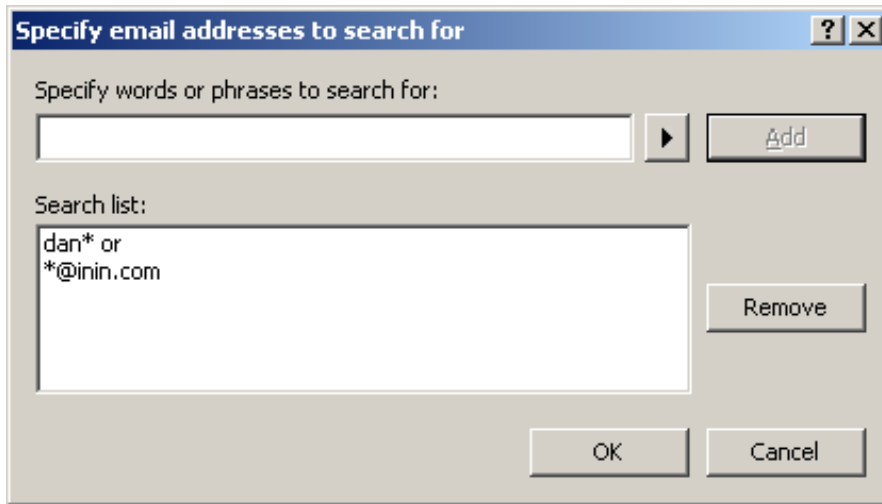

Email Condition Types

The conditions that a rule can examine after the message arrives are listed below.

From people

Compares email addresses in the **From** and **CC** fields to addresses you specify using the [Specify Search Words or Phrases](#) dialog. A match is found when any email addresses match your search criteria.

With any of the specific words in the subject

Compares specific words in the **Subject** field to words or phrases you specify using the [Specify Search Words or Phrases](#) dialog. A match is found when *any* words in the **Subject** field match your search criteria.

With all of the specific words in the subject

Compares specific words in the **Subject** field to words or phrases you specify using the [Specify Search Words or Phrases](#) dialog. A match is found when *all* words in the **Subject** field match your search criteria.

Marked with importance

Compares the email's **Importance** setting (high, low, or normal) to the level you select using the [Importance Level](#) dialog.

Sent to any of the people or distribution lists

Compares contents of the **From** and **CC** fields in a message to addresses or distribution lists you specify using the [Specify Search Words or Phrases](#) dialog. A match is found when *any* people or distribution lists match your search criteria.

Sent to all of the people and distribution lists

Compares contents of the **From** and **CC** fields in a message to addresses or distribution lists you specify using the [Specify Search Words or Phrases](#) dialog. A match is found when *all* people or distribution lists match your search criteria.

With any of the specific words in the body

Compares the body text of an email message to words or phrases you specify using the [Specify Search Words or Phrases](#) dialog. A match is found when *any* search criteria match words in the message body.

With all of the specific words in the body

Compares the body text of an email message to words or phrases you specify using the [Specify Search Words or Phrases](#) dialog. A match is found when *all* search words and phrases are found in the message body.

With any of the specific words in the subject or body

Compares the subject and body text of an email message to words or phrases you specify using the [Specify Search Words or Phrases](#) dialog. A match is found when *any* search words and phrases are found in the subject or message body.

With all of the specific words in the subject or body

Compares the subject and body text of an email message to words or phrases you specify using the [Specify Search Words or Phrases](#) dialog. A match is found when *all* search words and phrases are found in the subject or message body.

With any of the specific words in the recipients address

Compares email recipient addresses in the message with words or phrases you specify using the [Specify Search Words or Phrases](#) dialog. A match is found when *any* search words and phrases are found in the message header.

With all of the specific words in the recipients address

Compares email recipient addresses in the message with words or phrases you specify using the [Specify Search Words or Phrases](#) dialog. A match is found when *all* search words and phrases are found in the message header.

Where sender is in a specified distribution list

Looks to see if the sender's email address appears in the distribution list(s) you specify using the [Specify Distribution Lists](#) dialog. A match is found when the sender's name appears on one or more distribution lists.

Where a specific attribute is set to a specific value

This option looks to see if a specified custom attribute is attached to the email object. It compares the value of that attribute to specific values you specify. For example, you might use the [Email - Set Attribute](#) node to set a custom attribute at various entry points, and later use Email Transfer (with this option) to reroute the email interaction based on its origin.

To set the name and value of the attribute



1. Click on *a specific attribute* in the rule description to set the name of the attribute. The name you enter in the **Specify Attribute** input box can be anything you like, so long as it is not the name of a reserved system attribute. For information about reserved attributes that are used by CIC, refer to the [Interaction Attributes Technical Reference](#), in the PureConnect documentation Library.

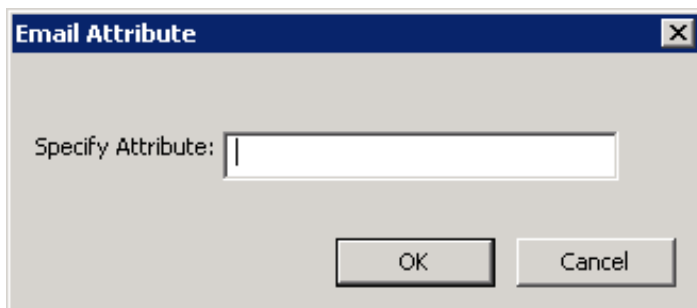

2. Click *a specific value* to [Specify Search Words or Phrases](#). The values you provide will be compared to the value of this attribute in incoming email messages.

Related Topics

- [Email Transfer](#)

Email Address Selection dialog

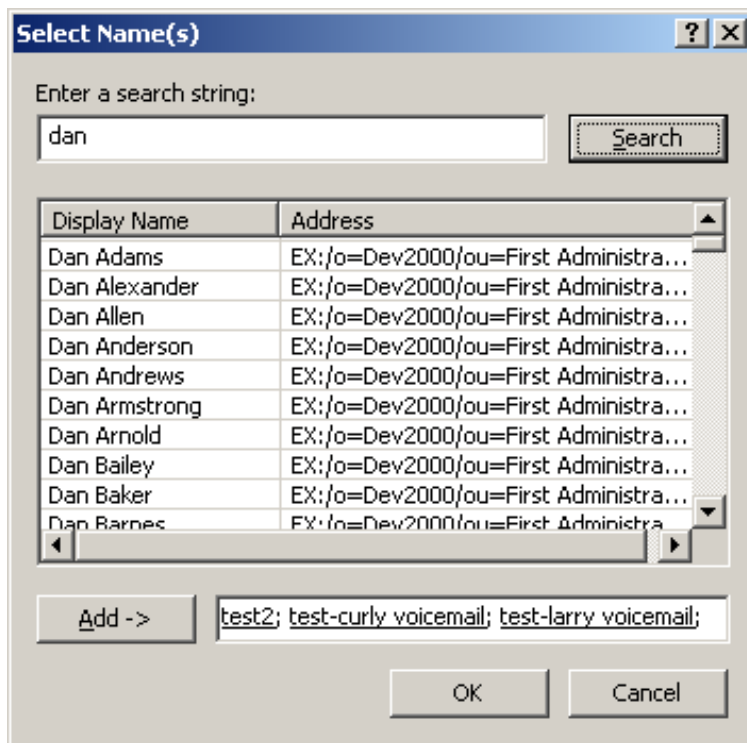

This dialog searches the email server to look up and validate email addresses. To use this dialog:

1. Type a portion of the email address in the **Enter Search String** field. Then press **Search**.
2. **Ctrl+Click** to select names from the list of results.
3. Press the **Add** button.
4. Press **OK** to return email address(es) to the calling dialog.

Related Topics

- [Build Email Reply](#)

Expression Type Wizard

The Expression Type wizard is opened from the property sheet of a call's [Logical Transfer](#) node by selecting the **Create Logical Expression** button. The wizard builds an expression by asking questions based upon the data type that you select.

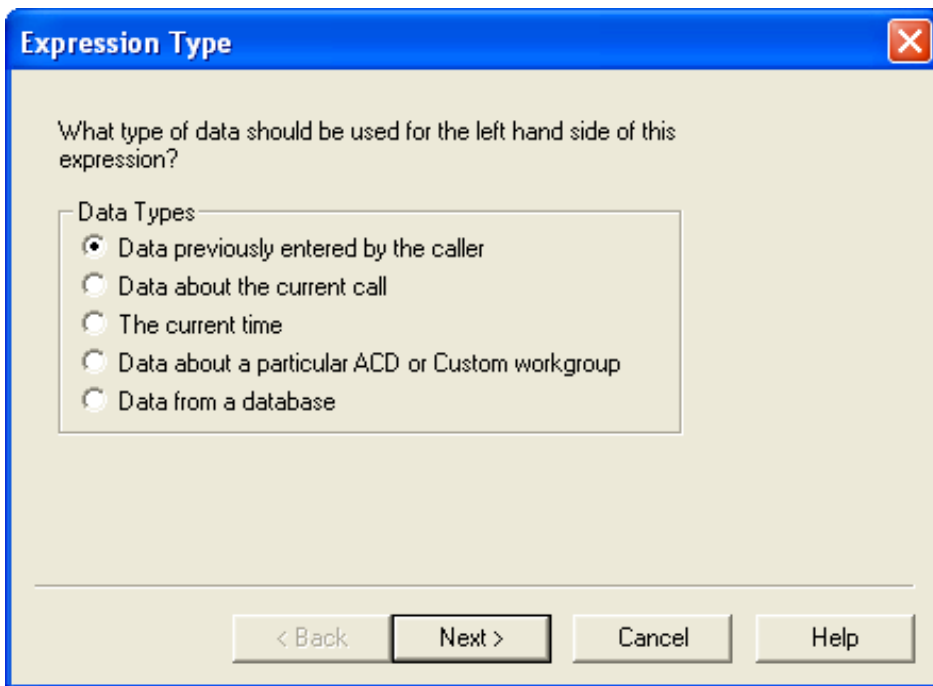

You can create an expression using:

- [Data previously entered by the caller](#)
- [Data about the current call](#)
- [The current time](#)
- [Data about a particular workgroup](#) (ACD or Custom)
- [Data from a database](#)

These options are explained in subsequent topics. When the wizard ends, the result of your expression is displayed in the *Expression to Evaluate* frame of the Logical Transfer node.

Related Topics

- [Logical Transfer \(Calls\)](#)

Data previously entered by the caller

Follow these steps to create a logical expression based upon *Data previously entered by the caller*:

1. If you have not done so already, open the Expression Type wizard by pressing the *Create Logical Expression* button on a [Logical Transfer](#) node.

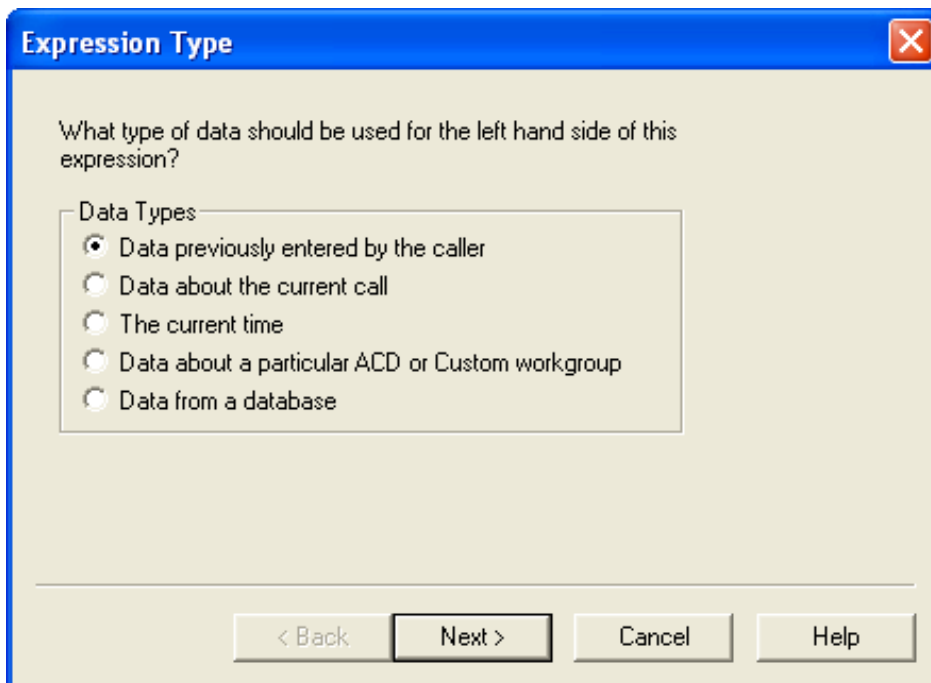

2. Select Data previously entered by the caller. Press Next.

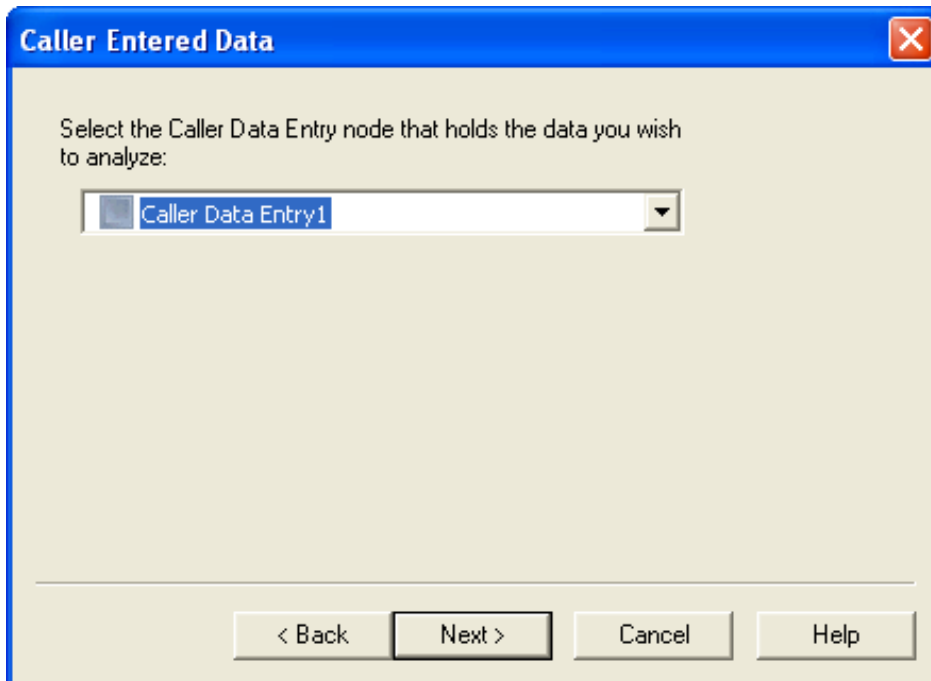

3. Select the [Caller Data Entry](#) node that holds the data you wish to analyze. Press *Next*.

The data entered by the user at node 'Caller Data Entry1' is

greater than

This value Data Type: String

100

The data retrieved by the DB query at node

No DB query nodes have been defined.

The data entered by the caller at node

Profile1

< Back Finish Cancel Help

4. Next, decide which comparison operator should be used to compare the caller data entry result to a value of some sort. Select one of the following:

- greater than
- greater than or equal to
- equal to
- not equal to
- less than or equal to
- less than

The next step is to define what the caller-entered data is compared to. You can enter a string, number, time, or Boolean value, or you can compare the digits entered by the caller to a database query result, or to data entered in another Caller Data Entry node.

For example, you might define Caller Data Entry nodes to prompt the caller for user ID and PIN information, and then use a DB Query to look up the PIN number from a database. Using this information, Logical Transfer can branch based upon whether the PIN entered by the caller matches the PIN stored in the file.

Type a value, select a [DB Query](#) node, or select a [Caller Data Entry](#) node. Use HH:MM:SS to specify a time value, and True or False to specify a Boolean value.

5. Press *Finish*. When the wizard ends, the result of your expression is displayed in the *Expression to Evaluate* frame, back on the [Logical Transfer](#) form.

Expression To Evaluate

The data entered by the user at node 'Caller Data Entry1' is equal to the data retrieved in the DB Query performed at node 'DB Query1'.

Modify Logical Expression

Related Topics

- [Expression Type Wizard](#)
- [Logical Transfer](#)

Data about the current call

Follow these steps to create a logical expression based upon data about the current call:

1. If you have not done so already, open the Expression Type wizard by pressing the *Create Logical Expression* button on a [Logical Transfer](#) node.

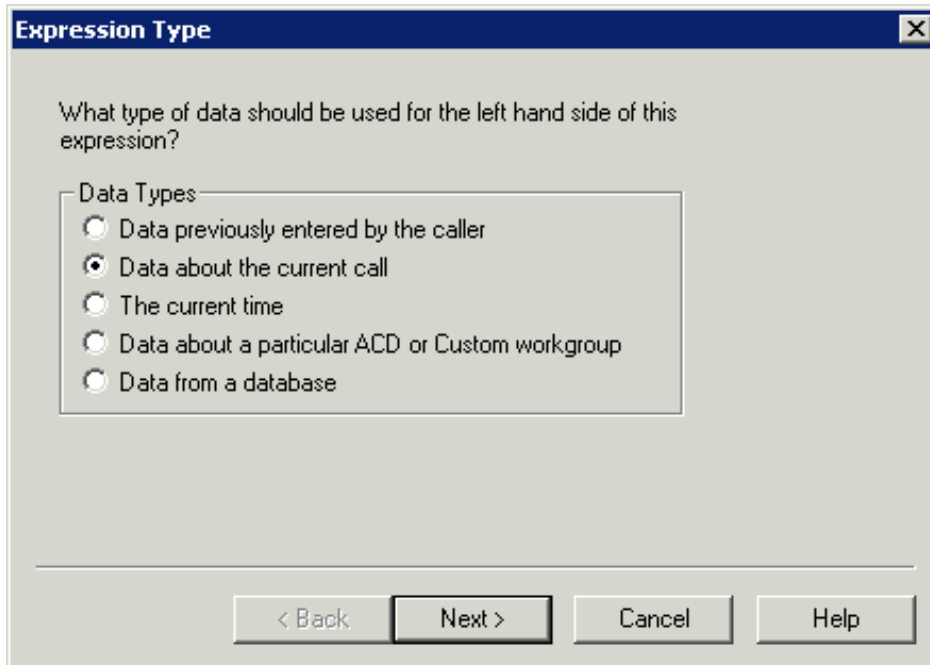

The dialog box is titled "Expression Type" and contains the question "What type of data should be used for the left hand side of this expression?". Below the question is a group box labeled "Data Types" containing five radio button options: "Data previously entered by the caller", "Data about the current call" (which is selected), "The current time", "Data about a particular ACD or Custom workgroup", and "Data from a database". At the bottom of the dialog are four buttons: "< Back", "Next >", "Cancel", and "Help".

2. Select Data about the current call. Press Next.

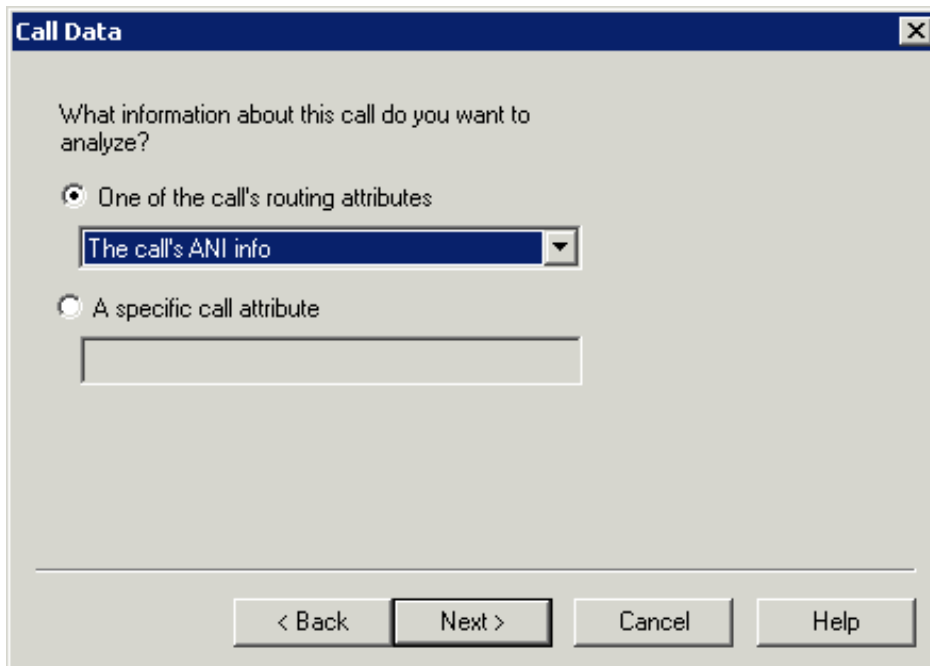

The dialog box is titled "Call Data" and contains the question "What information about this call do you want to analyze?". There are two radio button options: "One of the call's routing attributes" (which is selected) and "A specific call attribute". Below the first option is a dropdown menu with "The call's ANI info" selected. Below the second option is an empty text input field. At the bottom of the dialog are four buttons: "< Back", "Next >", "Cancel", and "Help".

3. The next step is to identify the call information to analyze. You can examine call routing attributes such as ANI, DNIS, or trunk line, or a call attribute. Select information to analyze, and then press *Next*.
4. The dialog that appears next depends upon the type of data you chose to analyze:

Note: You can create comparison operators for call routing attributes such as ANI, DNIS, trunk line, or call attributes, and compare against a value that is either a string value or a numeric value.

The call's ANI info

When you select this option, you are prompted to choose a comparison operator, a value, and a string or numeric data type. The value is the caller's telephone number entered as a string as it exists in the interaction attribute 'Eic_LocalTrn' (set when the call first arrives in the system) and is typically a full SIP address, or entered as a number without dashes in standard numeric telephone number format.

The call's ANI data is

equal to

Value: sip:joe@10.1.1.0

Data Type: String

< Back Finish Cancel Help

This screenshot shows a 'Call Properties' dialog box with a title bar containing a close button. The main area is titled 'The call's ANI data is'. Below this title is a dropdown menu set to 'equal to'. Underneath are two input fields: 'Value:' containing 'sip:joe@10.1.1.0' and 'Data Type:' containing 'String'. At the bottom, there are four buttons: '< Back', 'Finish', 'Cancel', and 'Help'.

The call's DNIS info

When you select this option, you are prompted to choose a comparison operator, a value, and a string or numeric data type. The value is the telephone number the caller dialed entered as a full SIP address, or entered as a number without dashes in standard numeric telephone number format.

The call's DNIS data is

equal to

Value: 111222333

Data Type: Number

< Back Finish Cancel Help

This screenshot shows a 'Call Properties' dialog box with a title bar containing a close button. The main area is titled 'The call's DNIS data is'. Below this title is a dropdown menu set to 'equal to'. Underneath are two input fields: 'Value:' containing '111222333' and 'Data Type:' containing 'Number'. At the bottom, there are four buttons: '< Back', 'Finish', 'Cancel', and 'Help'.

The call's trunk line

When you select this option, you are prompted to choose a comparison operator, and the trunk line that the caller is on.

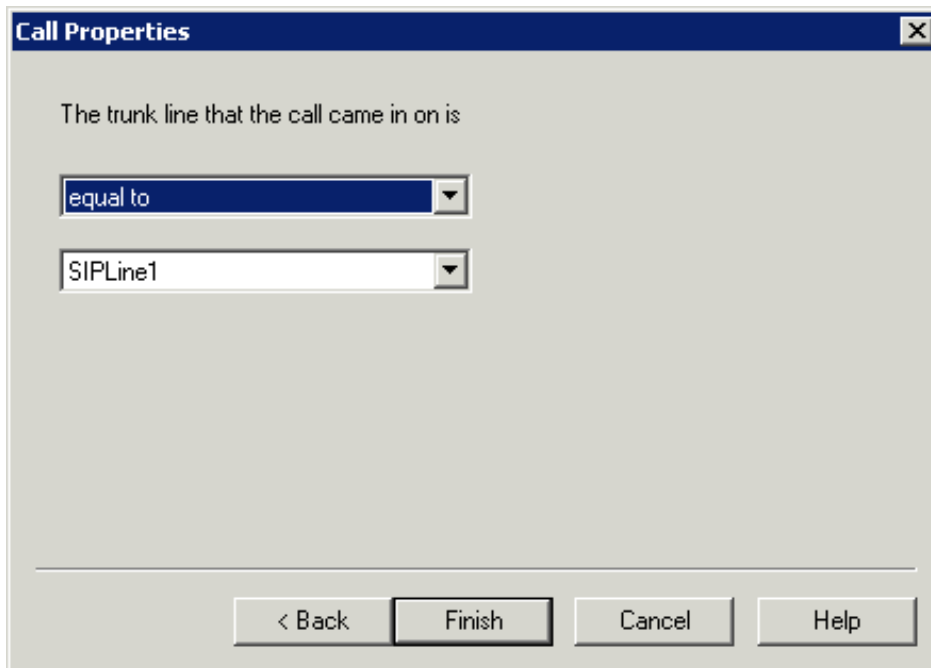

A specific call attribute

When you select this option, you are prompted to enter the name of a call object attribute. Press Next. Then choose a comparison operator, enter the value of the named call attribute, and select a string or numeric data type.

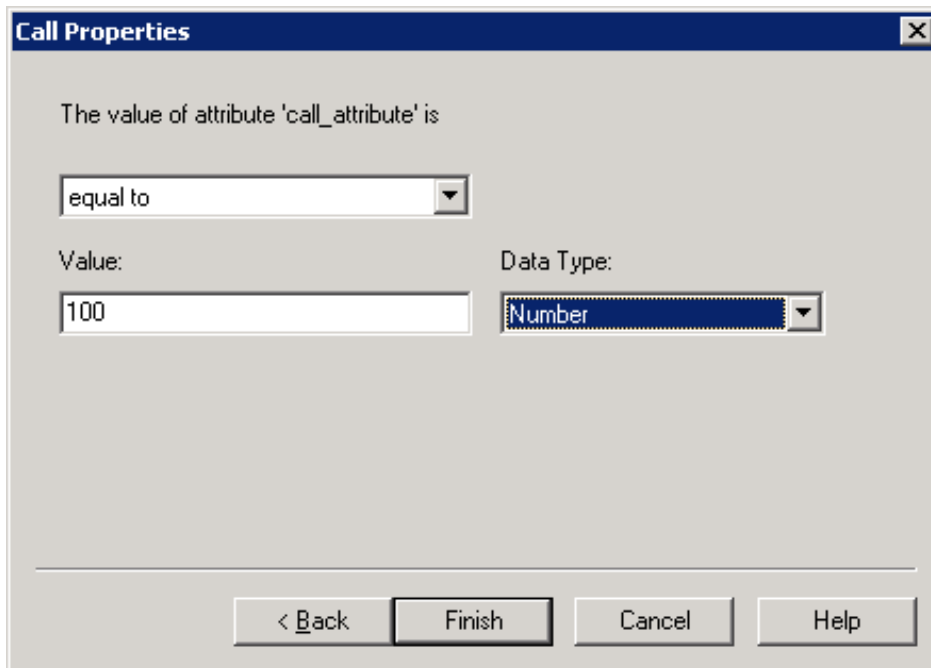

A *call attribute* is a piece of information about an object that travels with it throughout the Customer Interaction Center. For example, one standard attribute of a call object is the telephone number of the person who placed the call. A call object can have as many attributes as are needed. Attributes stay with a call until it is disconnected.

The CIC supports application programming interfaces (API's) that provide access to call object attributes. Dynamic Data Exchange (DDE) is commonly used to accomplish this, as is the Interaction Client Win32 COM API.

Attributes typically store information that is passed to a database or a third-party application. For example, CIC can be set up to "pop" a database application when an incoming call arrives at an agent's workstation.

For information about attributes, DDE and other APIs, see the *System APIs* section of the master documentation library on your CIC server. The *Interaction Attributes Technical Reference* describes attribute names that are reserved by CIC.

5. Press *Finish*. When the wizard ends, the result of your expression is displayed in the *Expression to Evaluate* frame, back on the [Logical Transfer](#) form.

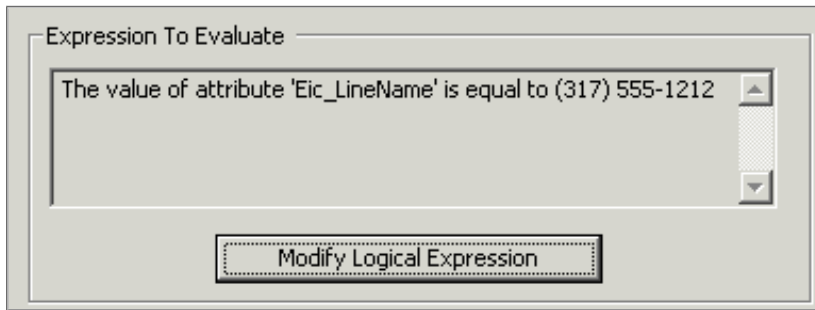

Related Topics

- [Set Attribute](#)
- [Expression Type Wizard](#)
- [Logical Transfer](#)

The current time

Follow these steps to create a logical expression based upon the current time:

1. If you have not done so already, open the Expression Type wizard by pressing the *Create Logical Expression* button on a [Logical Transfer](#) node.

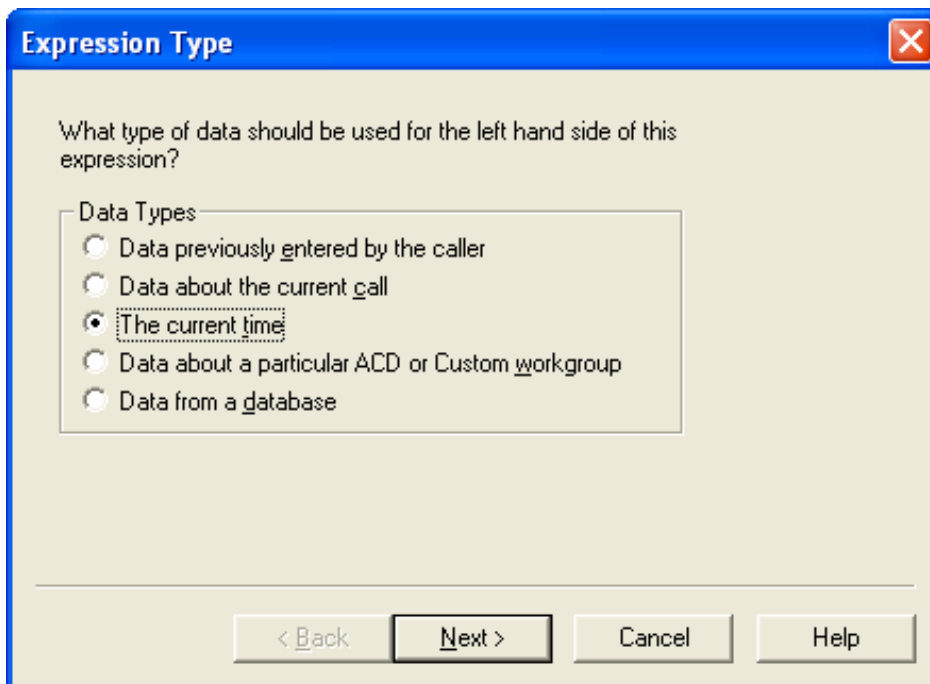

2. Select the current time. Press Next.

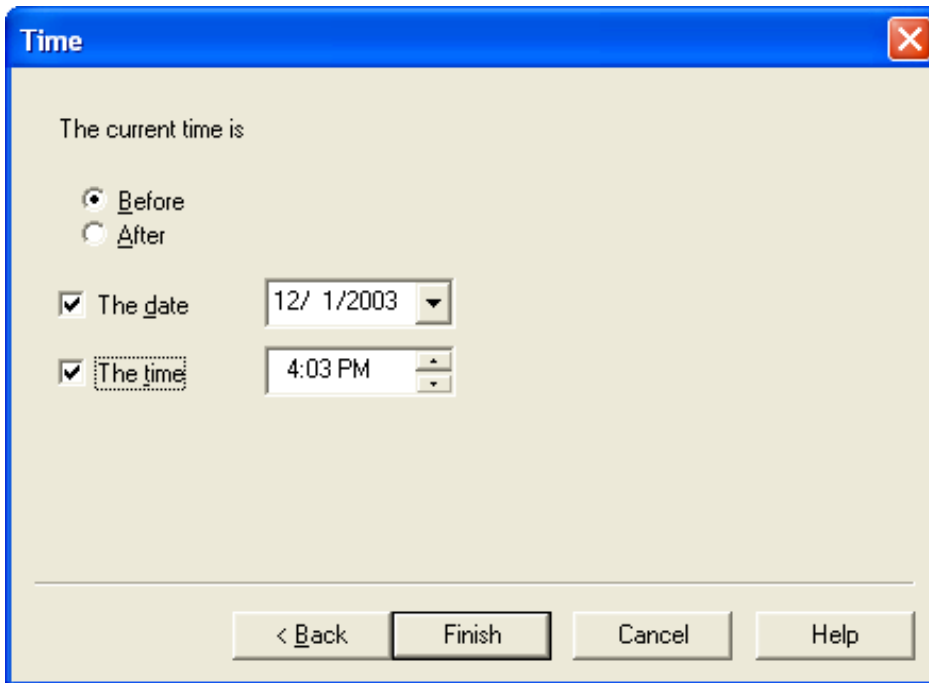

3. Select a comparison operator (Before or After) and date and time values. You must select a date or a time, or both.
4. Press Finish. When the wizard ends, the result of your expression is displayed in the *Expression to Evaluate* frame, back on the [Logical Transfer](#) form.

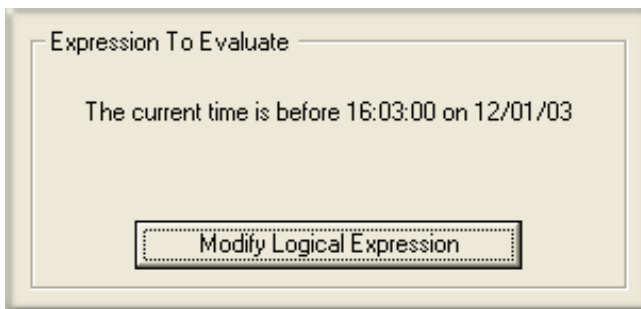

Related Topics

- [Expression Type Wizard](#)
- [Logical Transfer](#)

Data about a particular workgroup (ACD or Custom)

Follow these steps to create a logical expression based upon data about an ACD or custom workgroup:

1. If you have not done so already, open the Expression Type wizard by pressing the *Create Logical Expression* button on a [Logical Transfer](#) node.

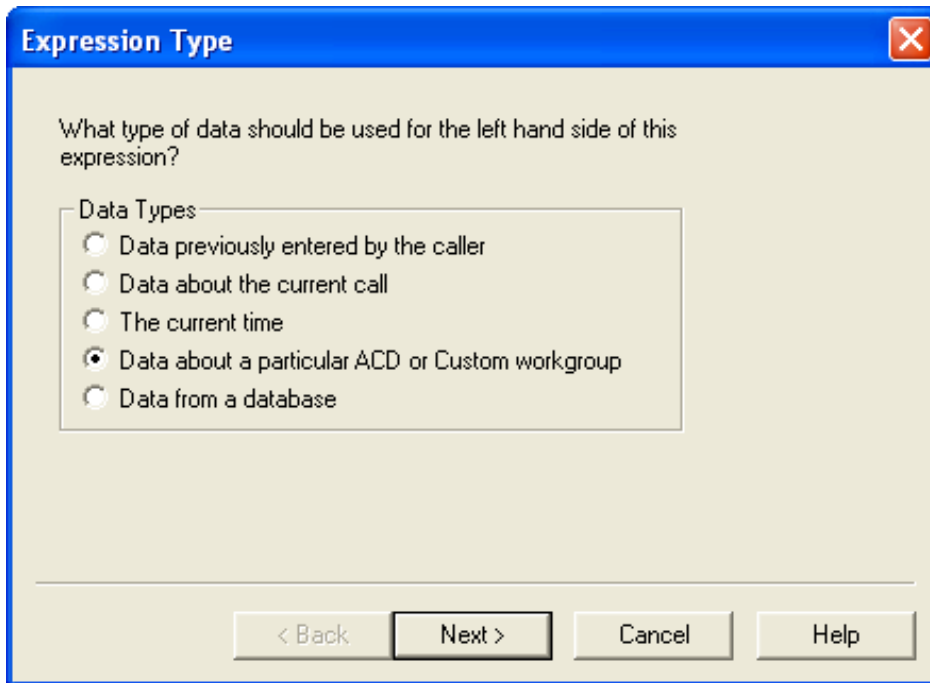

2. Select Data about a particular ACD or Custom workgroup. Press Next.

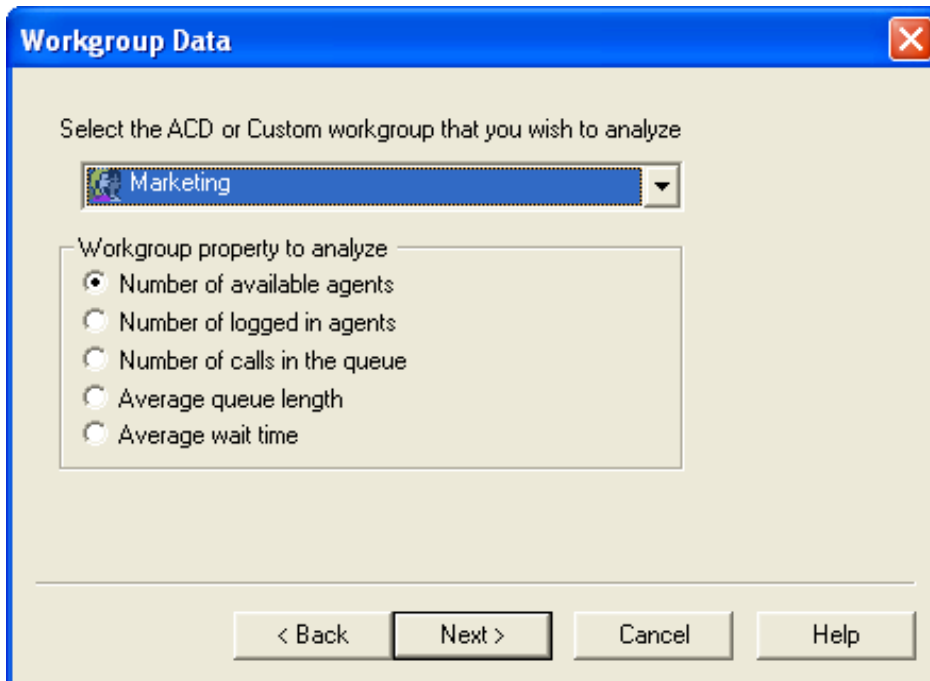

3. Select an ACD or custom workgroup to analyze.
4. Select a Workgroup property to analyze. Press Next to proceed. The dialog that appears next differs for each property selection. You can analyze based upon the number of available agents, the number of logged in agents, the number of calls in the queue, the average queue length, or the average wait time.

When you press *Next*, you are prompted to select a comparison operator for the selected property, and to define what the property is compared to—which can be either a predefined value or a runtime workgroup statistic.

Number of available agents

Select a comparison operator, and then define a value or statistic to compare the workgroup property to.

Number of logged in agents

Select a comparison operator, and then define a value or statistic to compare the workgroup property to.

The number of logged on agents can be inaccurate if the following scenario exists for the workgroup:

- A supervisor is a member of the workgroup
- And the supervisor logs on to IC Business Manager or Interaction Administrator
- And the supervisor logs on to Interaction Desktop or Interaction Connect.

If the workgroup meets this scenario, the CIC server increments the Logged On count due to the supervisor logons. The CIC server does not decrease the Logged On count until the supervisor logs out of both applications. To correct the Logged On count, you can remove the supervisor from the workgroup or set the [SetPersistedStatusOnLastStationLogout](#) server parameter to True.

Number of calls in the queue

The number of calls in workgroup 'Marketing' is

greater than

This value

0

The number of calls in workgroup

Marketing

< Back Finish Cancel Help

Select a comparison operator, and then define a value or statistic to compare the workgroup property to.

Average queue length

The Average Queue Length is the average duration of currently connected calls on the queue in seconds.

The average queue length in workgroup 'Marketing' is

greater than

This value

0

The average queue length in workgroup

Marketing

< Back Finish Cancel Help

Select a comparison operator, and then define a value or statistic to compare the workgroup property to.

Average wait time

Average wait time is calculated by adding the total wait time for all calls answered in a given period (the previous 30 minutes) and dividing that total by the number of calls answered in that period.

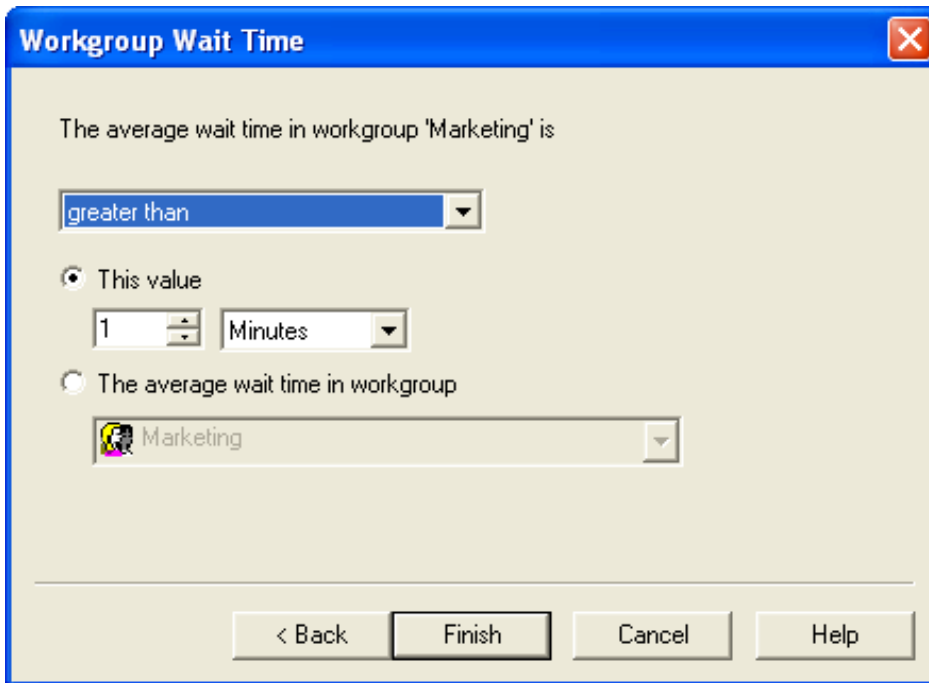

Select a comparison operator, and then define a value or statistic to compare the workgroup property to.

5. Press *Finish*. When the wizard ends, the result of your expression is displayed in the *Expression to Evaluate* frame, back on the [Logical Transfer](#) form.

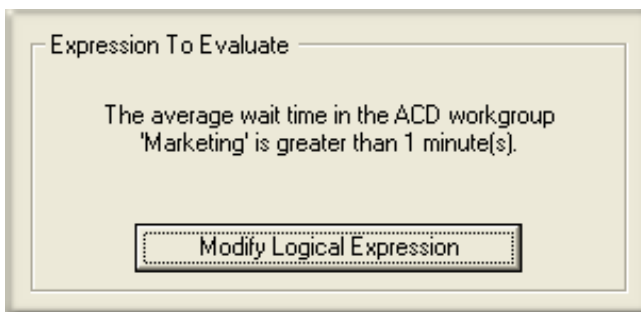

Related Topics

- [Expression Type Wizard](#)
- [Logical Transfer](#)

Data from a database

Follow these steps to create a logical expression based upon data retrieved from a database:

1. If you have not done so already, open the Expression Type wizard by pressing the *Create Logical Expression* button on a [Logical Transfer](#) node.

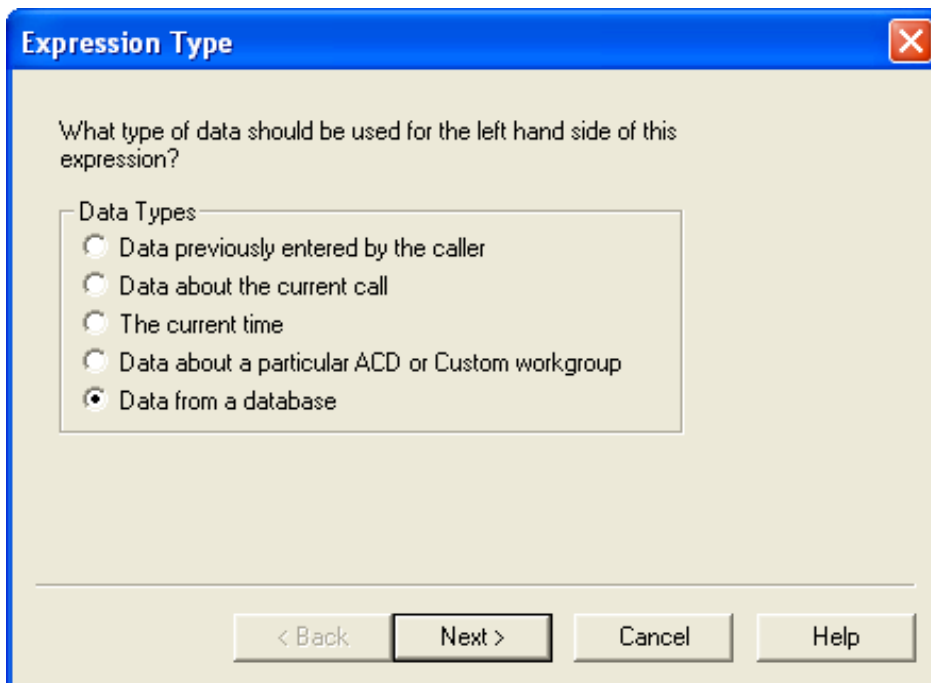

2. Select Data from a database. Press Next.

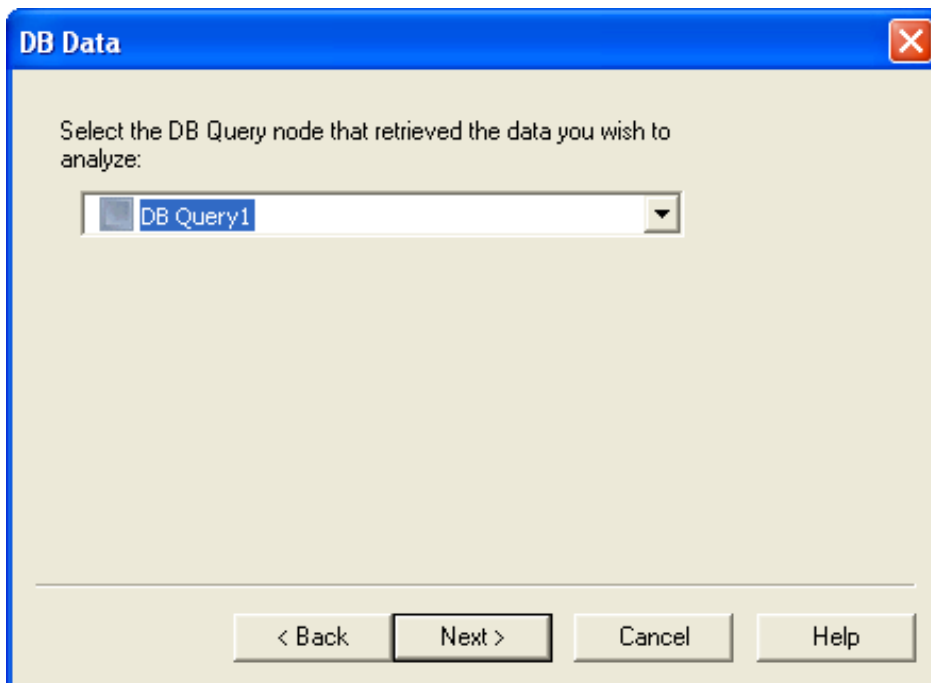

3. Identify the [database query](#) that retrieves the data to be analyzed.

The data retrieved in the DB Query at node 'DB Query1' is

greater than

This value Data Type:

1000 Number

The data retrieved by the DB query at node

The data entered by the caller at node

No data entry nodes have been defined.

< Back Finish Cancel Help

4. Select a comparison operator, and then define the value, query result, or call-entered data that the database query result will be compared to.
5. Press *Finish*. When the wizard ends, the result of your expression is displayed in the *Expression to Evaluate* frame, back on the [Logical Transfer](#) form.

Expression To Evaluate

The data retrieved in the DB Query at node 'DB Query1' is greater than 1000.

Modify Logical Expression

Related Topics

- [Expression Type Wizard](#)
- [Logical Transfer](#)

Fax Listener Options Dialog

This dialog appears when the *Fax Options* button is pressed from a [schedule](#) node.



Fax Listener check box

When this option is enabled, Interaction Attendant listens for Fax tones, so that Fax handling is automatically invoked should a call arrive from a Fax machine. If a fax tone is detected, the fax is received in the Default Mailbox, or in the user or workgroup mailbox that you specify.

Send the fax to frame

The Default Mailbox radio button

Sends incoming Faxes to the default mailbox that was defined for the server using Interaction Administrator.

User's Mailbox radio button

Sends incoming Faxes to the user mailbox that you select.

Workgroup's Mailbox radio button

Sends incoming Faxes to the workgroup mailbox that you select.

Related Topics

- [Default Inbound Call Schedule](#)
- [Custom Inbound Call Schedule](#)

Formatting Help Dialog

This dialog appears when the *Formatting Help* button is pressed on a call profile form. It displays tips for using wildcards and for entering ranges in fields that filter a profile based upon DNIS or ANI values. When you are finished, press *OK* to dismiss the dialog.

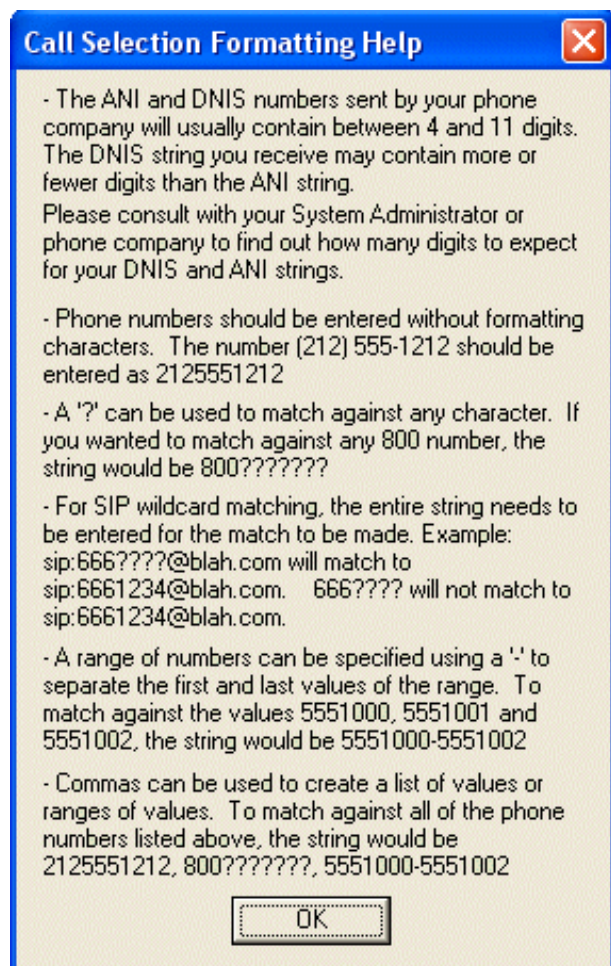

Formatting DNIS/ANI routing for SIP

In a SIP/HMP environment, special care must be taken when formatting wildcards for ANI and DNIS profiles. Matches can fail when wildcards are used, since Wildcard matching compares STRINGS and allows for ? to match.

For example, 666666? does not match sip:6666666@domain.com, since the range matching looks at 6666666 part of the DNIS and treats it as a number. The Wildcard does not. In order to work correctly, the exact string needs to be entered in the DNIS routing:

sip:666????@xxx.x.xx:5060 or sip:666????@domain.com:5060

Range matching always works if you specify an exact telephone number (e.g. 4445555).

Related Topics

- [Custom Inbound Call Profile](#)
- [Custom Operator Profile](#)
- [Profiles](#)

Importance Level dialog

This dialog prompts for a level of importance to match against the *Importance* setting of an Email message. The importance of an Email can be high, low, or normal.

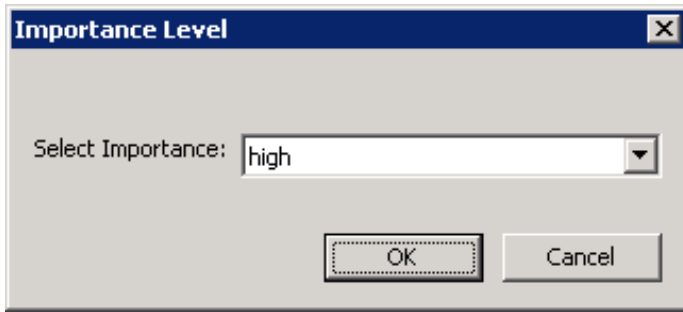

Make a selection from the drop list. Then press *OK* to return your selection to the [Email Rules Wizard](#). If you press *Cancel*, the dialog is dismissed without returning a value to the wizard.

Related Topics

- [Email Transfer](#)
- [Email Rules Wizard](#)

Logon Dialog

The Logon dialog appears when you [connect to a server](#). Connecting to a server allows you to edit its Attendant profiles. To put changes into effect, you must [publish a configuration](#).

Username

A valid Username for the CIC server you are connecting to.

Password

The corresponding password for the CIC username.

Server

The name of the CIC server that you are connecting to.

OK button

Submits login information for authentication by the system. If the login information you enter is valid, the server's configuration is loaded into Interaction Attendant for editing, and a node for the [server](#) appears in the tree structure.

Cancel button

Closes the dialog without attempting to connect to a server.

Related Topics

- [Connect to a server](#)

Mailbox Selection dialog

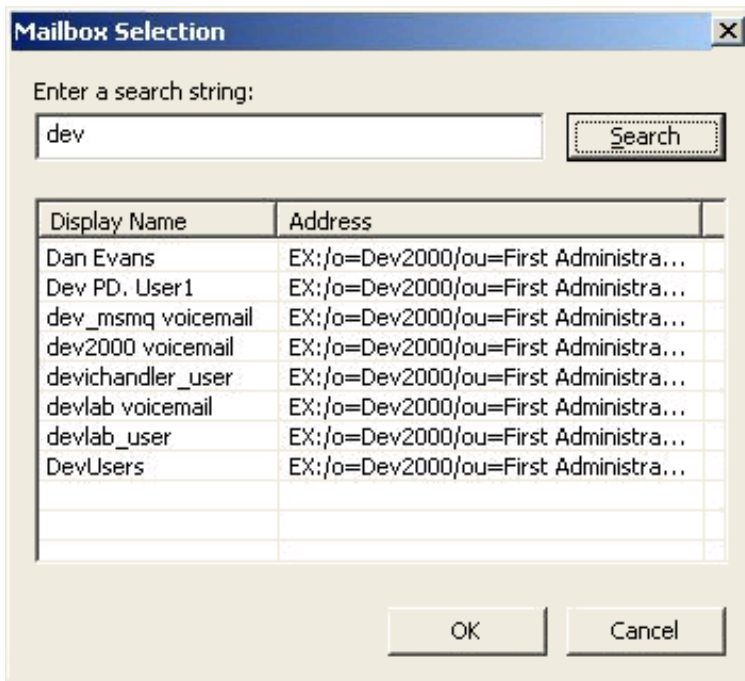

Display Name	Address
Dan Evans	EX:/o=Dev2000/ou=First Administra...
Dev PD, User1	EX:/o=Dev2000/ou=First Administra...
dev_msmq voicemail	EX:/o=Dev2000/ou=First Administra...
dev2000 voicemail	EX:/o=Dev2000/ou=First Administra...
devichandler_user	EX:/o=Dev2000/ou=First Administra...
devlab voicemail	EX:/o=Dev2000/ou=First Administra...
devlab_user	EX:/o=Dev2000/ou=First Administra...
DevUsers	EX:/o=Dev2000/ou=First Administra...

Mailbox selection queries CIC's configured Email server to return a list of matching mailboxes. It allows the user to select a mailbox. When OK is pressed, the name of the selected mailbox is returned to the calling function.

To locate a mailbox

1. Type all or part of a mailbox name in the **Enter a search string** field.
2. Press the **Search** button.
3. Select a mailbox from the list of matching results.
4. Press **OK**. The name of the selected mailbox will be returned to the calling dialog.

Visual Controls

Enter a search string field

This field prompts for all or part of a mailbox name.

Search button

Queries the server to return a list of matching mailboxes.

OK button

Returns the name of the selected mailbox and closes the dialog.

Cancel button

Closes the dialog without returning a mailbox name.

Related Topics

- [Email - Disconnect](#)

Prompt Management Dialog

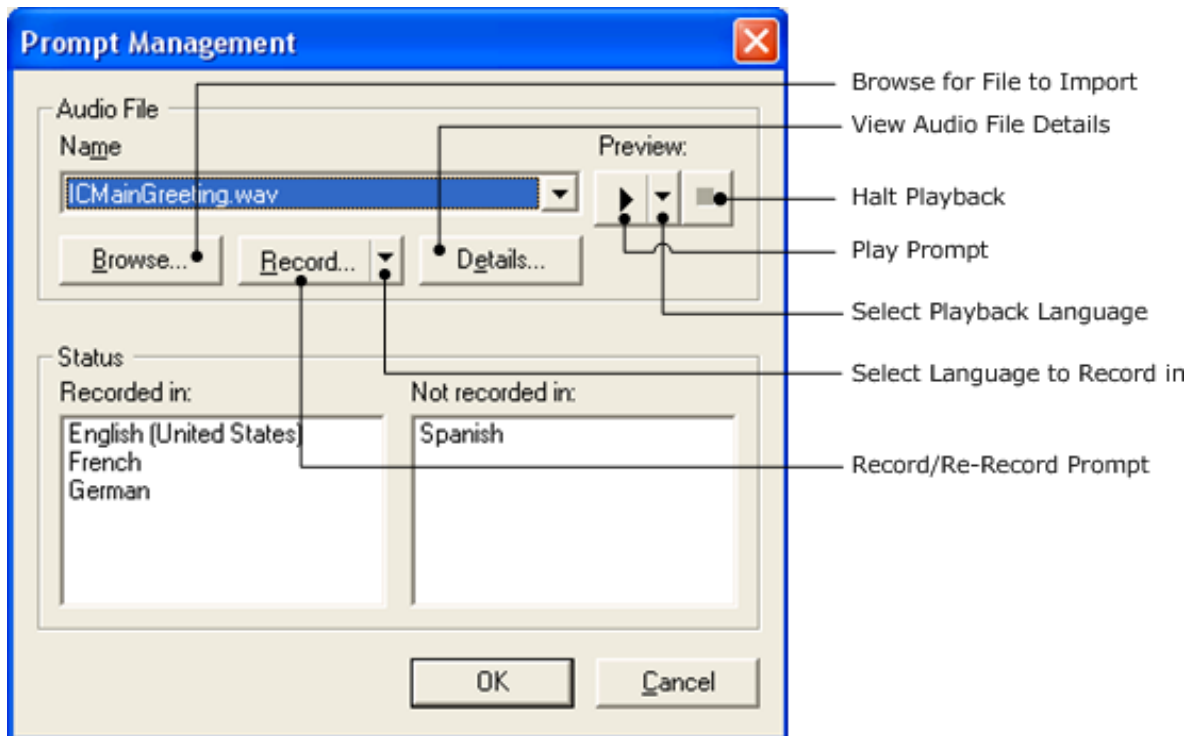

The *Prompt Management* dialog contains the usual embedded audio controls, but also displays which languages a prompt has been recorded in. This makes it easy to manage multi-language prompts at a high level, without having to open forms.

This dialog appears when *Multi-Language Prompts* is selected from the *Edit* menu. Use the *Prompt Management* dialog to:

- Select and play back a prompt in different languages.
- Record, or re-record a prompt in any language defined in Interaction Administrator. If you need to record in a language that does not appear in Interaction Attendant's list of available languages, see [configure CIC to support additional languages](#).
- Using this dialog, prompts can be recorded in additional languages. However, the dialog does not determine which language is used to play a prompt in a menu. (The [current language](#) setting does that.) It merely allows a language to be selected before playing back or recording a prompt.
- Browse for a .wav file.
- View audio file details.
- When you select a prompt using the Name list box, the Status list on the left displays a list of languages that the prompt has been recorded in. The "Not recorded in" list on the right indicates available languages for which the prompt has not been recorded. In the example above, the prompt has been recorded in English, French, and German, but not Spanish.

To Select An Existing Prompt

Select a prompt from the Name list box. The list of languages that the prompt has been recorded in appears in the Status frame.

To Play Back an Existing Prompt

1. Select the name of a prompt from the Name list box. When you make a selection, the list of supported languages that the prompt has been recorded in appears in the Status frame. The list of languages the prompt has not been recorded in appears on the right.
2. Select the playback language by pressing the down arrow to the right of the Play button. Select an item in the list.
3. Press the Play button.

To Record (or Re-record) a Prompt in Another Language

1. Select a prompt from the Name list box.
2. Press the down arrow next to the Record button to display a drop-down list of supported languages.
3. Select the language that you want to record in. Checkboxes in the list (if any) indicate languages that the prompt has already been recorded in. When you make a selection, you are prompted to pick up your telephone:
4. Pick up your telephone, and press OK to proceed. Follow verbal instructions as needed to complete the recording.

To Record a New Prompt

1. When you record a new prompt, you do not need to select a language beforehand. The [default language](#) (as configured in Interaction Administrator) is associated with new prompts recorded in Interaction Attendant.
2. To get started, press the Record button. The Audio Prompt Name dialog appears, so that you can provide a name for the new prompt.
3. Enter a name for the prompt. (The .wav extension will be added if you do not type this in.) Press the OK button to close the Audio Prompt Name dialog.
4. When you press the OK button, Attendant asks you to pick up your telephone:
5. Press OK to proceed. Then follow verbal instructions as needed to complete the recording.

To Browse for a Prompt File

You can browse for an existing .wav file. The file that you select is copied to a directory named C:\IC\Resources\InteractionAttendantWaves\LANGUAGE on the CIC server, where LANGUAGE is the name of the [default language](#) defined in Interaction Administrator. This directory is shared as \AttendantWaves\LANGUAGE.

1. Press the Browse button.
2. Select a .wav file using the Open dialog.
3. Press the Open button.

Usage

The Multi-Language Prompts command is invoked by pulling down the *Edit* menu and selecting *Multi-Language Prompts*.

- [An easier way to manage multi-language prompts](#)
- [Manage Voice Prompts](#)

Results Processing Dialog

This dialog defines actions to take when [DB Query](#) results are returned, and actions to take if the query does not return a result. It also tells the text-to-speech system how to pronounce the results of the query—as text, digits, a date, monetary value, etc.

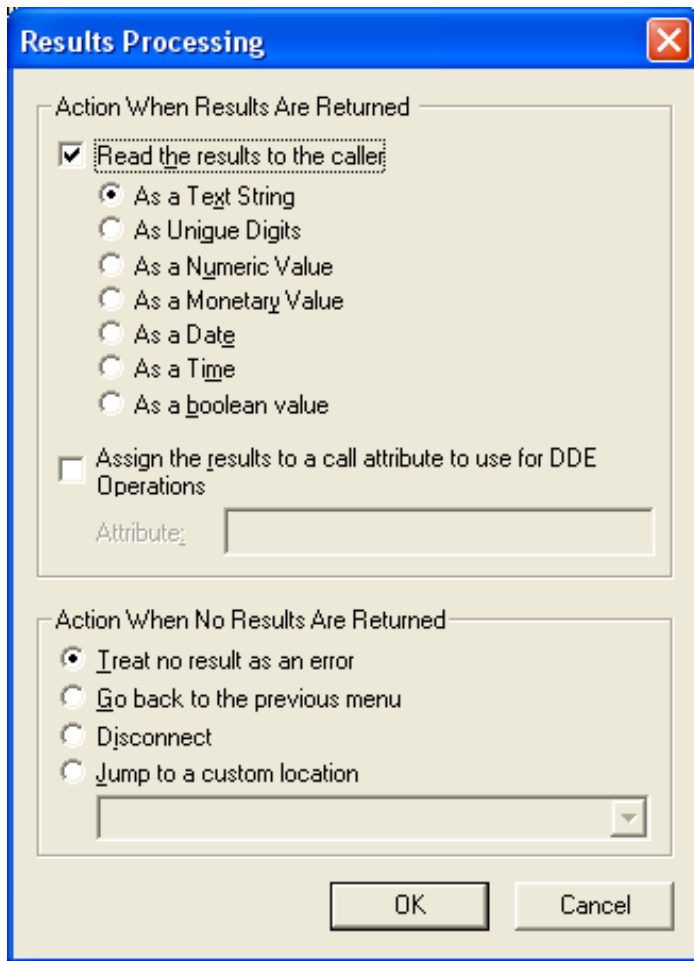

Action When Results Are Returned frame

This frame controls the processing that occurs when a [DB Query](#) returns data—anything other than a null result. It determines whether data is read back to the caller, and assigns the appropriate text-to-speech pronunciation method for that data type. You can optionally assign the query result to a call attribute.

Read results to the caller check box

This option controls whether or not the query result will be converted to speech and read back to the caller.

As a Text String radio button

Choose this option to have the query result read back to the caller as a text string.

As Unique Digits radio button

If you choose "As Unique Digits", 1234 will be read back as "one two three four".

As a Numeric Value radio button

If you choose "As a numeric value", 1234 will be read back as "one thousand, two hundred and thirty four".

As a Monetary Value radio button

If you choose, "As a monetary value", 1234 will be read back as "twelve hundred thirty four dollars and zero cents". 1234.50 is read back as "twelve hundred thirty four collars and fifty cents".

As a Date radio button

Choose this option to have the query result read back to the caller as a date. Dates are pronounced using the names of months instead of numbers. (e.g. 8/2000 is read as "August two thousand".)

As a Time radio button

The query result will be read back as a time of day.

As a boolean Value radio button

The query result will be read back as "True" or "False".

Assign the results to a call attribute to use for DDE Operations check box

Optionally assigns the query result to any call attribute that you specify.

Only the field specified by *Column to Retrieve* (in the DB Query form) can be assigned to a call attribute. You cannot assign a row of data to a call attribute.

An *attribute* is a piece of information about a call object that travels with it throughout the Customer Interaction Center. For example, one standard attribute of a call is the telephone number of the person who placed the call. A call object can have as many attributes as are needed. Attributes stay with the call until it is disconnected.

CIC supports application programming interfaces (API's) that provide access to call object attributes. Dynamic Data Exchange (DDE) is commonly used to accomplish this, as is the Interaction Client Win32 COM API. Attributes typically store information that is passed to a database or a third-party application. For example, CIC can be set up to "pop" a database application when an incoming call arrives at an agent's workstation.

For information about attributes, DDE and other APIs, see the PureConnect Documentation Library. The *Interaction Attributes Technical Reference* describes attribute names that are reserved by CIC, including those whose value you should not change. If you assign data to a standard CIC attribute, you could potentially affect the execution of a handler.

Attribute name field

Enter the name of the attribute that will contain the query result. Every attribute has a *name* (e.g. Account Number) and a *value* (such as the query result). Call attribute names can contain spaces and special characters.

Do not start call attribute names with the letters Eic_, unless you intend to assign the result to an attribute that is reserved by CIC. The CIC uses Eic_ prefixes to identify a standard call attributes. If you overwrite a standard attribute, you could accidentally interfere with normal operation of the CIC server. As mentioned earlier, the *Interaction Attributes Technical Reference* discusses reserved attribute names and whether or not they are safe to update.

Action When No Results Are Returned frame

This frame controls the processing that occurs if a query does not return any data—a null result may not indicate an error condition. Control can be passed to logic that provides "no record found" processing. Alternately, you can treat null results as "real errors" that require standard error handling.

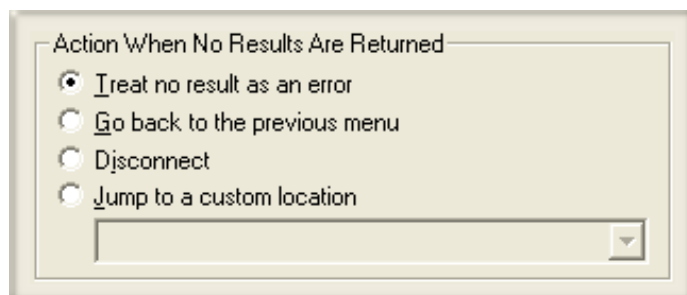

Action When No Results Are Returned

- Treat no result as an error
- Go back to the previous menu
- Disconnect
- Jump to a custom location

_____ ▾

Treat No Result as an error

This option passes control to Attendant's built-in error processing if the query does not return data.

Go back to the previous menu

This option returns control to the menu that is the parent of this operation. This sets up a simple loop that reruns the parent menu from the top.

Disconnect

This option disconnects the call if no query results are returned.

Jump to a custom location

This option passes control to any [profile](#), [schedule](#), [menu](#), or [operation](#) that is defined for the current server.

Ok button

Saves the selections that you have made and closes the dialog.

Cancel button

Closes the dialog without saving selections.

Related Topics

- [Database Operations](#)
- [DB Query](#)

Same User Lock Dialog

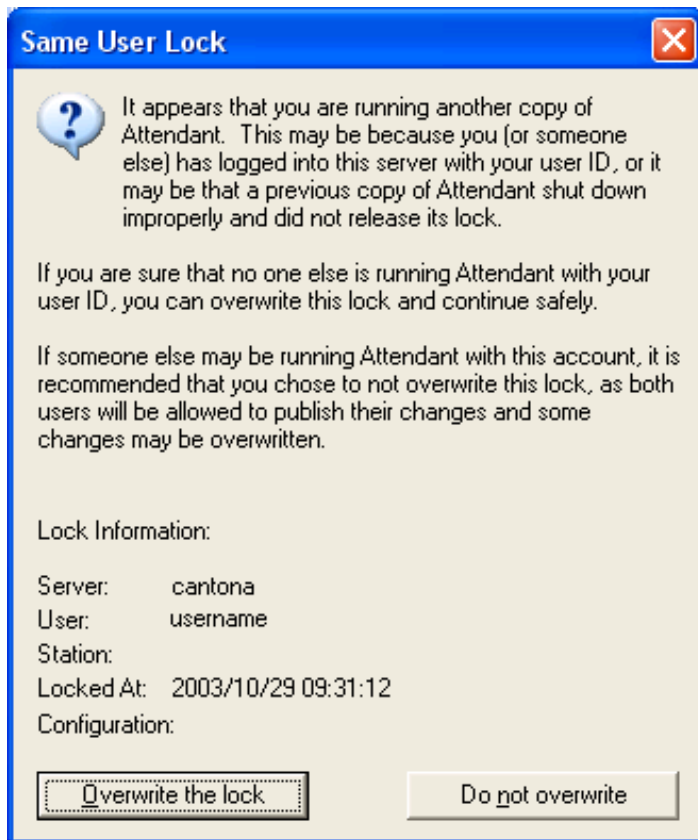

This dialog appears when a second instance of Interaction Attendant connects to a server using your ID. If no one else is running Attendant with your User ID (perhaps you started Attendant twice), you can overwrite this lock and continue safely.

If someone else is using your ID, you should not overwrite the lock. If you do, Attendant will allow both of you to publish changes that could collide logically with one another.

Note—it's safe to run more than one instance of Interaction Attendant if you connect to *different* CIC servers. If you connect multiple instances to the same server, Interaction Attendant won't stop you from saving a configuration that is open in another session. This could potentially lose changes made in another instance. To warn you of this situation, Interaction Attendant displays the Same User Lock dialog.

Server

The name of the server whose configuration is locked.

User

The login ID of the person who is currently editing the configuration.

Station

The station name or telephone number where the user is working from.

Overwrite the lock button

Removes the lock applied by the other person. Thereafter you may view, edit, export and publish configuration data for the server *—as can the other user*. Since that could cause configuration conflicts, we recommend that you do not overwrite the lock.

Do not overwrite button

Closes the dialog without removing the lock. Thereafter you may use Attendant to view and modify the configuration, but it will not allow you to publish changes to the server. To save your edits, you must [backup export](#) the your configuration to a disk file, and

[import](#) it later when the lock has been removed.

Related Topics

- [Connect to a Server](#)
- [Manage Configuration Files](#)

Save Changes Dialog

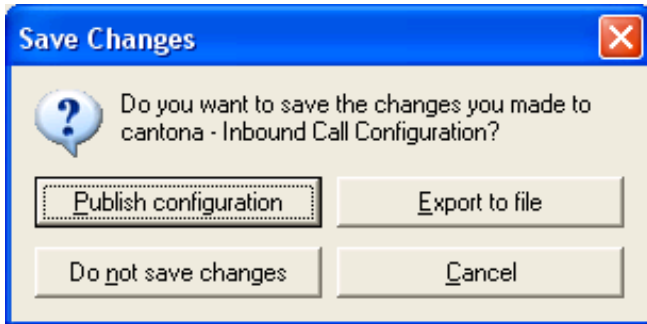

The *Save Changes* dialog appears if configuration information has changed, when Attendant is closed or a server is disconnected. It provides the opportunity to publish, discard, or export changes to a file, or cancel the close/disconnect operation.

The *Save Changes* dialog is displayed for each connected server whose loaded configuration information has changed.

Publish Configuration button

Updates that server's configuration using the information that is currently loaded into Interaction Attendant.

Export to file button

Saves configuration information in a generic, full, or backup file. See [Manage Configuration Files](#).

Do not save changes button

Closes the Save Changes dialog, discarding any edits that you have made for the server.

Cancel button

Closes the dialog without shutting down Attendant or disconnecting the server.

Specify Search Words or Phrases to search for dialog

In the case of the **Specify email addresses to search for** dialog, the search function searches for whole strings in the address field, not substrings.

This dialog prompts for *words* or *phrases* for an Email rule to find in a message. It appears when a hyperlink is pressed in the [Email Rules Wizard](#):

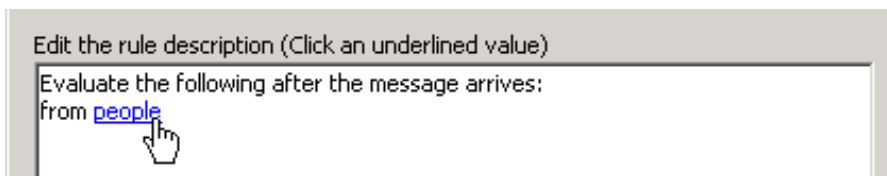

Note that the dialog caption varies to prompt for different types of input. However, operation of the dialog is the same, regardless of [Email condition type](#).

Specify words or phrases to search for

This field prompts for words and phrases to find in an Email message. In the case of the email message body, the search function uses substring to match words.

Add button

Adds a search word or phrase to the Search list

Search list

This field stores all search entries that you have added.

Remove button

Removes the item selected in the Search list.

OK button

Closes the dialog, and passes the *Search list* to the Email Rule.

Cancel button

Discards user input and closes the dialog

To specify words or phrases

1. Type a word, part of a word, or a phrase in the *Specify words or phrases to search for* field. Since the search function uses substring to match words in the message body, you can search for a root word and it will find variations of that word. For example, search for "cancel" would match on "canceled", "cancelling" or "Cancels". You can also use wildcards for single (?) or multiple characters (*). For example, to search for similar model numbers with one digit and letter difference you can use a question mark such as ATT?1?00.
2. Press the *Add* button.
3. Repeat steps 1 and 2 for define other search words or phrases as needed. To remove unwanted entries from the *Search List*, press the Remove button.
4. When you are finished, press *OK* to close the dialog.

Related Topics

- [Email Rules Wizard](#)

Specify Distribution Lists dialog

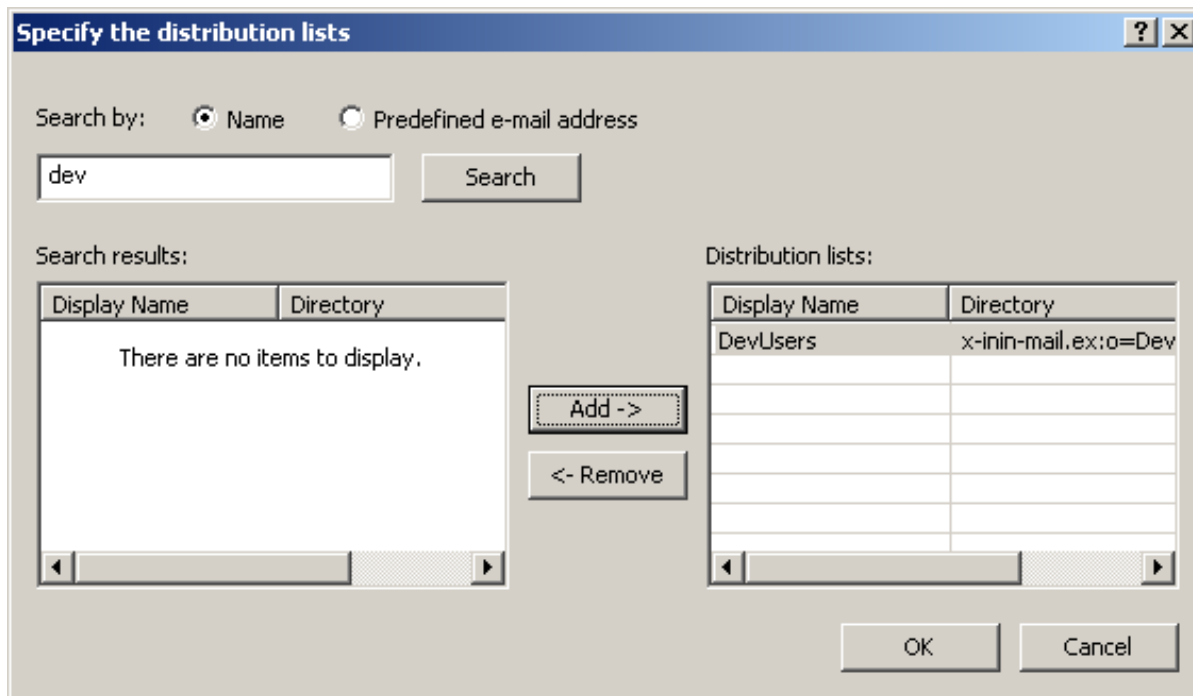

This dialog prompts to select the sender's distribution list for an Email rule to find in a message. It appears when a *distribution list* hyperlink is pressed in the [Email Rules Wizard](#):

Search by radio buttons

These buttons indicate whether the search string is a distribution list name, or an Email address.

Search button

Queries the Email server to find matching email addresses or distribution lists in the *Search Results* list.

Search results field

The results of searching the Email directory are listed here.

Distribution lists field

This field contains items that the user has added to his search criteria.

Add button

Adds the item selected in the Search results list to the Distribution Lists field.

Remove button

Removes the item selected in the Distribution Lists field, so that it is no longer used as search criteria by the Email rule.

OK button

Closes the dialog, and passes the contents of *Distribution lists* to the Email Rule.

Cancel button

Discards user input and closes the dialog.

To specify distribution lists or predefined Email addresses

1. Use the radio buttons to indicate whether the search string will be a distribution list name, or an Email address.
2. Type all or a portion of the distribution list or Email address in the *Search by* field. You can optionally use wildcards to specify single (?) or multiple characters (*). For example, to retrieve all distribution lists that start with dev, you would type "dev*" with a wildcard.
3. Press the Search button.
4. Select items in the Search results list. Then press *Add* to move them to the list of selected items on the right.
5. Repeat steps 1 through 4 to define other search criterion as needed. To remove unwanted entries from the Distribution lists field, press the *Remove* button.
6. When you are finished, press *OK* to close the dialog. The items you selected will be passed to the [Email Rules Wizard](#).

Servers Dialog

The Servers dialog appears when *Manage Servers* is selected from the Edit menu, or when the Manage Servers toolbar button  is pressed. This dialog restricts commands to the connected servers that you select. It also allows you to connect to additional servers.

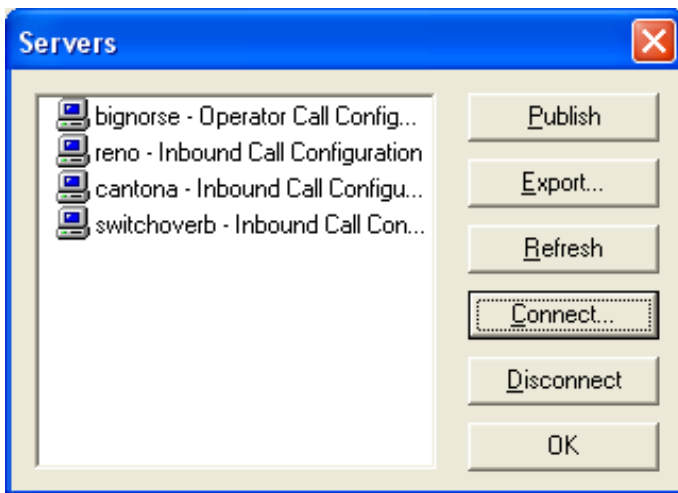

It displays a list of servers that you are connected to, along with the type of call flow configuration that is open for editing. To apply a command to one or more servers, follow these steps:

1. Select one or more servers in the list. Shift-click to select contiguous items in the list. Control-click to select discontinuous items. To connect to a server, you do not need to select items from the list.
2. Press the button that corresponds to the command you wish to perform. The command is applied to those servers that are selected in the list, rather than to all connected servers.
 - *Publish* saves configuration changes for the selected servers.
 - *Export* creates a disk file that contains the selected servers' configuration information.
 - *Refresh* retrieves *server* configuration information from each selected server. This tells each server to send Interaction Attendant information about its workgroups, schedules, users, stations, skills, DB sources, lines, line groups, schedules, languages, and its default language. These data items are defined and administered using Interaction Administrator, and may have changed while you were using Interaction Attendant.
 - *Connect* opens the Interaction Attendant login dialog.
 - *Disconnect* releases the Notifier connection to the selected servers. In effect, this "logs off" Interaction Attendant from the selected servers.
3. Interact with dialogs as needed to complete the command.
4. Press *OK* to close the dialog.

Scope of Publish Command

Care must be taken not to publish a configuration unintentionally. The publish command applies to all loaded configurations unless you use the Servers dialog to restrict publishing to specific servers.

To publish configurations for all servers displayed in the user interface, select *Publish* from the *File* menu or press the  (Publish) button on the main toolbar.

To publish configurations for selected servers, pull down the *Edit* menu and select *Manage Servers*. Ctrl-click in the server list to select the names of servers that you wish to update. Then press the *Publish* button.

Related Topics

- [Publish a Configuration](#)
- [Export a Configuration File](#)
- [Refresh Server Data](#)
- [Connect to a Server](#)
- [Disconnect from a server](#)

Stale Lock Dialog

The Stale Lock dialog appears when the configuration of a server that you are connecting to has been locked for more than 24 hours. This typically indicates that the user did not shut down Attendant properly. Attendant displays information about the lock, and provides the option to override it.

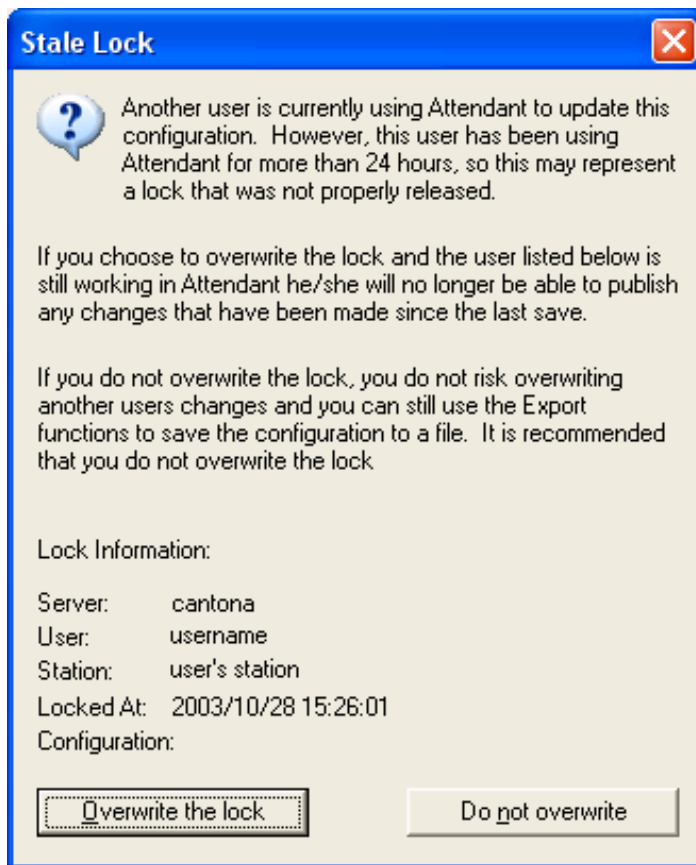

Locks grow *stale* after Attendant is abnormally terminated by a user (due to a machine crash, etc.) When you overwrite a lock, you can edit and save changes to the server configuration.

Server

The name of the server whose configuration is locked.

User

The login ID of the person who is currently editing the configuration.

Station

The station name or telephone number where the user is working from.

Overwrite the lock button

Removes the lock applied by the other person. Thereafter you may view, edit, export and publish configuration data for the server without any restrictions. When press this button, you are prompted to confirm your decision:

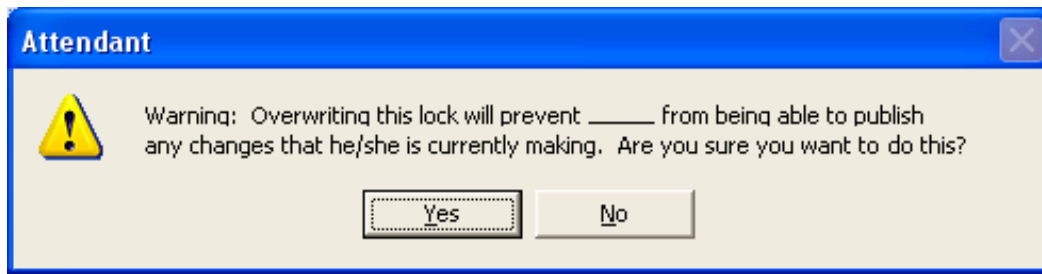

Press *Yes* to remove the lock. If you press *No*, you can use Attendant to view and modify the configuration, but it will not allow you to publish changes to the server. To save your edits, you must [backup export](#) the your configuration to a disk file, and [import](#) it later when the lock has been removed.

Do not overwrite button

Closes the dialog without removing the lock. Thereafter you may use Attendant to view and modify the configuration, but it will not allow you to publish changes to the server. To save your edits, you must [backup export](#) the your configuration to a disk file, and [import](#) it later when the lock has been removed.

Related Topics

- [Connect to a Server](#)
- [Manage Configuration Files](#)

Threaded Email Options Dialog (Email)

This dialog appears when the *Threaded Email Options* button is pressed on the [Transfer to a Workgroup](#) node for an email interaction. This dialog allows the designer to specify that email interactions be sent to the first or last workgroup that handled the email interaction.

Note: This option is only available if conversation identifier (CID) generation is enabled in Interaction Administrator and an Interaction Tracker license is enabled. For more information about these features, or if you have questions about your right to use it, see your CIC administrator.

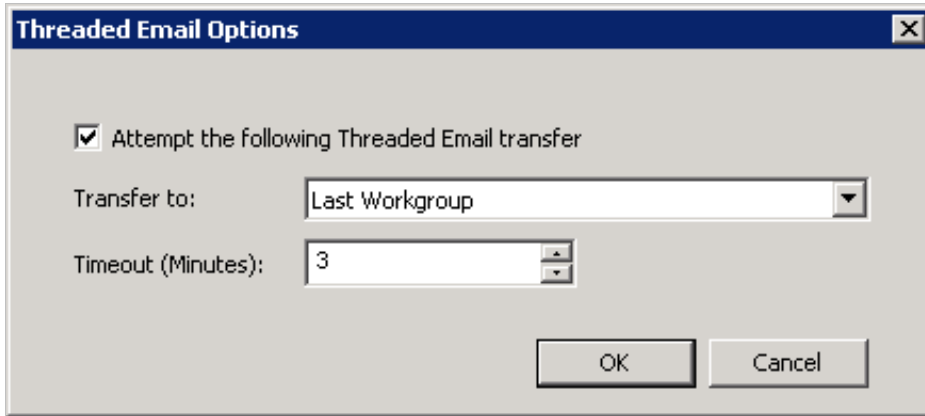

The screenshot shows a dialog box titled "Threaded Email Options" with a close button (X) in the top right corner. Inside the dialog, there is a checked checkbox labeled "Attempt the following Threaded Email transfer". Below this, there are two fields: "Transfer to:" with a dropdown menu currently showing "Last Workgroup", and "Timeout (Minutes):" with a spinner box currently showing "3". At the bottom of the dialog are two buttons: "OK" and "Cancel".

Attempt the following Threaded Email Transfer

Select this check box to specify email is transferred based on the settings you choose in this dialog.

Transfer to drop down list

Click the Transfer to: drop down list and choose to send the email interaction to either the First Workgroup or Last Workgroup that worked with the email.

Timeout (Minutes) drop down list

Use the up and down arrows to select the number of minutes the interaction stays in the selected workgroup queue until it is answered. After the timeout limit is reached, the system will transfer the email message to the workgroup specified on the [Transfer to a Workgroup](#) node.

Related Topics

- [Email - Transfer to a Workgroup](#)

Update Column Dialog

This dialog identifies which column (field) will be updated by [DB Update](#), and the data that will be assigned to the field.

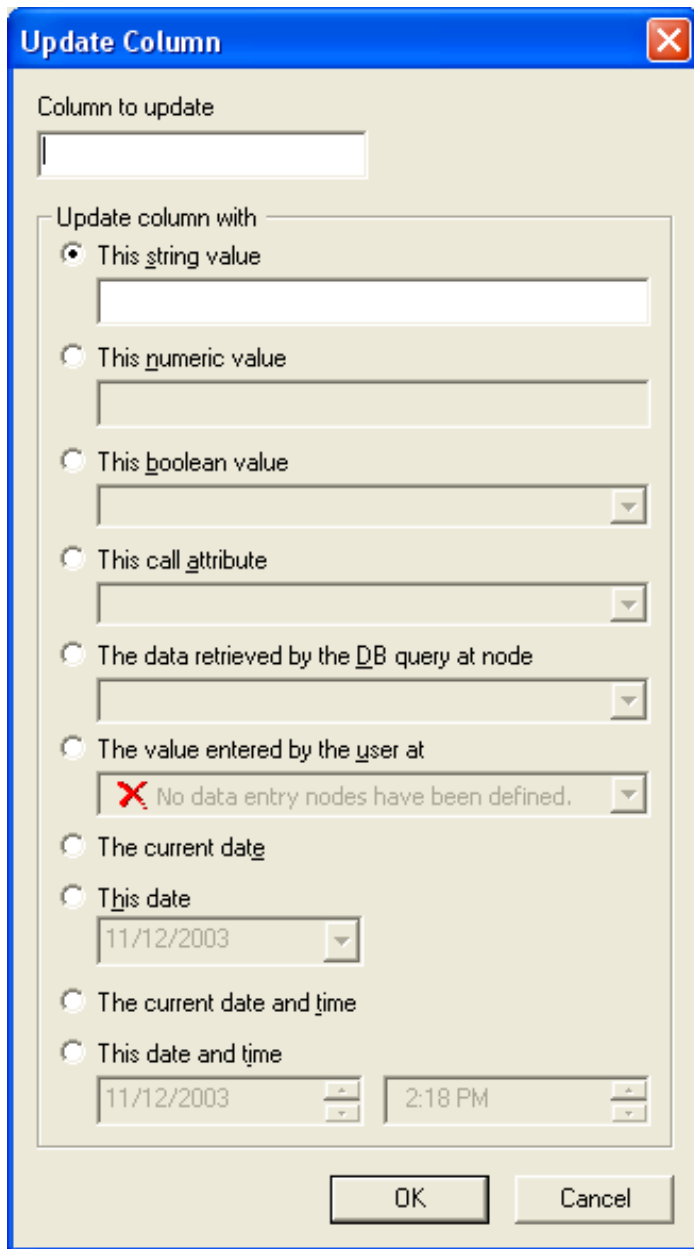

Column to update field

Identifies which field that will be updated in the table. The remaining options on this dialog define the data to place in the field.

This string value

Assigns alphanumeric data to the column.

This numeric value

Assigns numeric data to the column updated.

This boolean value

Assigns a value of True or False to the column updated.

This call attribute

Assigns one of the following call attributes to the column updated:

- ANI—the caller's telephone number.
- Caller ID—the caller's name.
- DNIS—the telephone number that was dialed.
- Interaction ID Key—a unique ID number that identifies a call. This key is always unique, while Call ID number may not be.
- Line Name—the CIC line name that the call came in on.

Data retrieved by the DB query at node

Allows you to assign the value returned by a [DB Query](#) to the column updated. The combo box is empty unless the server configuration contains at least one DB Query.

The value entered by the user at

This option assigns a string of data collected by a [Caller Data Entry](#) operation to the column updated.

The current date

Assigns the current date to the column updated. The date format is YYYY-MM-DD.

This date

Assigns any date that you select using a calendar field to the column updated.

The current date and time

Assigns the current date and time to the column in YYYY-MM-DD HH:MM:SS format.

This time

Assigns any date and time that you select to the column updated.

Ok button

Saves the selections that you have made and closes the dialog.

Cancel button

Closes the dialog without saving selections.

Related Topics

- [Database Operations](#)
- [DB Update](#)

Dynamic Call Attributes

Call attributes are string values associated with the current call throughout its lifetime; they remain with a call even when it is transferred. These attributes are used not only within Attendant but also by many other CIC components on both the server and client side.

Eic_AttrCallbackCopyAttributes

Set this attribute before the Request Callback node is processed. This attribute should contain a pipe delimited list of all attributes that should be moved over to the callback object.

Eic_AttDynamicSkillstoAdd

This attribute contains a list of skills that can be added to an in-queue interaction.

Eic_AttDynamicSkillsToRemove

This attribute contains a list of skills that can be removed from an in-queue interaction.

Eic_AttDynamicUserVmail

This attribute contains the user selected for voicemail transfer.

Eic_AttDynamicWorkgroupVmail

This attribute contains the workgroup to use for the voicemail transfer.

Eic_AttDynamicWorkgroupName

Use this attribute to organize multiple workgroups. For example, you can define your workgroups by area of expertise, such as web service calls or custom handler calls.

Eic_AttDynamicWorkgroupSkills

Defines a skill set based on one or more defined skills. The skills designated in this attribute must be separated using the pipe-delimited format. For example, if you want to specify that agents assigned to this interaction attribute contain multiple language skills, enter the value for this attribute as "Spanish" or "Spanish|French|Norwegian".

Eic_AttDynamicWorkgroupPriority

Assigns priority value for interactions specified for a specific workgroup.

Eic_AttDynamicAgentName

Specifies the agent or user to which specific interactions are sent.

Eic_AttDynamicExternalNumber

Defines the external telephone number to which designated interactions are transferred.

Glossary

ANI

ANI stands for Automatic Number Identification. ANI is often called Caller ID. All phone calls contain the numbers of the dialing phone. Those numbers can be displayed on a screen or used by the receiving phone system to tell the call recipient useful information.

Audio Prompts

Audio prompts are the messages (with the file extension .wav) that Interaction Attendant plays to callers. Examples include the greeting played for callers when the call is picked up, and any instructions played to describe menu options. A default set of prompts is installed with Interaction Attendant. You can change these prompts and add your own. You might do this so that all prompts are spoken in the same voice.

Attendant Configuration File

Attendant Configuration (.att) files contain all of the information that is associated with a server profile, including its schedules, and settings affecting operations. Attendant Configuration files make it quick and easy to back up or restore a particular server configuration. The File | Import File command reads in an .att configuration file. Likewise, the File | Export File command saves an .att configuration file for the all connected servers.

Audio Playback

Audio playback plays a .wav file to caller. You can use the .wav files that are installed with Interaction Attendant, or you can record your own .wav files and store them in a language-specific folders below the AttendantWaves share on the CIC server.

Auto Attendant

Auto attendant is a shortened name for automatic attendant. An auto attendant is a device that automatically answers a call, prompts a caller to make menu choices, and routes a call according to that caller's choice. Callers choose options by pressing keys on their telephone. Based on the caller's choice, an auto attendant will offer a sub menu, transfer a call to a queue, allow callers to search an employee directory, send or receive a fax, or perform many other actions. Interaction Attendant is the tool for configuring CIC's auto attendant.

Auto Attendant Processing

Auto Attendant Processing is a call processing style that interacts with the caller using menus. See also: Direct to Queue Processing.

Backup Export

A export option that saves server-specific information that must be imported by the same server.

Call Attribute

A call attribute is a piece of information about an object that travels with it throughout the Customer Interaction Center. For example, one standard attribute of a call object is the telephone number of the person who placed the call. A call object can have as many attributes as are needed. Attributes stay with a call until it is disconnected. The CIC supports application programming interfaces (API's) that provide access to call object attributes. Dynamic Data Exchange (DDE) is commonly used to accomplish this, as is the Interaction Client Win32 COM API. Attributes typically store information that is passed to a database or a third-party application. For example, the CIC can be set up to "pop" a database application when an incoming call arrives at an agent's workstation. For more information about attributes, DDE and APIs, see the PureConnect Documentation Library. The *Interaction Attributes Technical Reference* describes attribute names that are reserved by CIC. If you assign data to a standard CIC attribute, you could potentially affect the execution of a handler. The *Interaction Attributes Technical Reference* identifies attributes whose value you should not change.

Call Flow Configuration

A *call flow configuration* processes inbound calls, outbound calls (those placed by Interaction Dialer), or calls to the Operator. Attendant displays each call flow in its own tree view. Tabs below the tree view allow you to switch to a different call flow configuration. The call flow and tabs that you see (if any) are determined by whether or not you have rights to view or modify a given call flow type, and by command line switches that specify which call flows you want to see.

Call Processing Style

Call processing styles determine whether Auto Attendant Processing or Direct to Queue Processing are used to process an inbound telephone interaction.

Current Language

The language used to play back a voice prompt. The current language is set using profile forms, or by allowing callers to select a language from a menu (using Language Selection operations). Attendant plays back voice prompts and performs text-to-speech operations in the appropriate language based upon this information.

Customer Interaction Center (CIC)

The Customer Interaction Center (CIC) is designed for sophisticated contact centers managing inbound, outbound, or blended interactions. CIC provides skills-based routing not only for telephone interactions, but faxes, Emails, text chats, Web call-back requests, and voice over IP calls. CIC can support up to several hundred agents per site, and offers optional pre and post-call routing across multiple locations. And it makes screen popping a breeze, with easy interfaces to products from leading CRM vendors such as Siebel, Pivotal, Onyx, Peoplesoft, and many more.

Default Action

The operation defined by the default node that is performed if the caller does not press a key within the timeout period specified by that menu. The icon for default forms has a green border in the tree structure.

Default Language

The names of supported languages (e.g., English, French, Spanish, etc.) are defined on each CIC server using Interaction Administrator. Handlers that play voice prompts use these language attributes internally. The default language is used to play system prompts when no other language attribute is specified.

Default Node

The form whose default action check box is checked.

Dial by Name

Dial by Name allows a caller to enter the first three characters of a Interaction Client user's last name. Dial by Name then searches for the extension and transfers the call to that user.

Direct to Queue Processing

Direct to Queue Processing is a call processing style that sends a call to the user queue, station queue, or workgroup queue specified in the profile. Users may be returned to Auto Attendant processing if the call is not picked up from a queue in a specified number of seconds.

Direct to Queue performs special processing for each of the supported queue types. The call is trapped before normal queue processing takes place so that the Attendant handlers can maintain control. All custom prompts, call coverage options, and thin client rules are bypassed while direct to queue processing is in effect.

DNIS

Dialed Number Identification Service (DNIS) is a feature of digital T-1 and ISDN lines (like 800 and 900 lines) that provides the number the caller dialed. DNIS is a system by which CIC can determine what number a caller dialed. Knowing that dialed number allows Interaction Attendant to perform unique processing on that call, such as playing special messages or offering special menu choices. For example, a company has two levels of technical support, silver and gold. Silver members call 555-1111, and Gold members call 555-2222. In Interaction Attendant you can create a profile for each number. When callers dial 555-2222, they hear the profile for gold support. When callers dial 555-1111, they hear the profile for the silver. The *Default Inbound Call Profile* is used when no DNIS information accompanies the call, or when the DNIS is not recognized.

Full Export

A export option that saves all configuration data that is not tied to a server to an Attendant configuration file. This allows an exact copy of one server's configuration to be loaded on to an identically configured server. It is frequently used to move a configuration from a test server to a production server. The source server must be identical to the destination server in terms of line names, workgroup names—everything except server name and password.

CIC Server

The Customer Interaction Center (CIC) is a client/server software product that transforms a Windows NT server into a comprehensive communications system. The CIC server answers and processes calls. The profiles you create in Interaction Attendant are saved to the CIC Server where they are executed when a call is picked up.

Dial Extension

Allows a caller to dial an Interaction Client user's extension. If a match is found, the call is transferred; if not, the caller is returned to the menu from which Dial Extension was called. See the Dial Extension operation.

External Transfer

This operation transfers a call to specified telephone number outside of the CIC.

Fax Back

Allows a caller to request a fax and send it to a fax number that the caller specifies. Fax Back functionality in Interaction Attendant requires some handler modification.

Handler

Handlers are programs that the CIC Server executes to respond to an event, such as an incoming call. Handlers are created using Interaction Designer, the visual programming tool included with Customer Interaction Center. Few users of Interaction Attendant ever need to create or modify handlers. The sophisticated handlers included with Interaction Attendant are sufficient to meet all but the most extraordinary needs. However, it is important to understand that handlers work behind the scenes to implement the profiles and menus that you create using Interaction Attendant.

A handler performs an action or actions in response to the occurrence of some event. A handler is simply a collection of steps that are organized and linked to form a logical flow of actions and decisions.

Incoming Call Selection

Incoming Call Selection is enabled on custom profile forms. You can filter calls to various schedules based upon the line or line group used, the number dialed (DNIS), or the caller ID (ANI). A server's default profile does not support this feature, since the default profile is intended as a catch all.

Interaction Attendant

The graphical tool for configuring and maintaining CIC's auto attendant.

Interaction Designer

The CIC graphical application development tool for creating, debugging, editing, and managing handlers and subroutines.

Interaction ID Key

Interaction ID Key is a unique ID number that identifies a call. This number is always unique, while Call ID numbers may not be.

IVR

Interactive Voice Response (IVR) allows phone users to use their telephone keypad as a keyboard to input values in response to voice prompts played by a computer.

Line Name

Every line coming into CIC has an assigned line name. You can view and change these line names in the Lines container in Interaction Administrator. In Interaction Attendant, line names can be assigned to a profile form. Any call that comes in on the named line is processed by that profile. When assigning line names to profiles, refer to the Interaction Administrator lines container for a list of line names.

Menu

The group of operations that Interaction Attendant performs, based upon user selections, are collectively called a menu. A menu is a set of operations that appear below a schedule or another menu in the tree structure. A caller selects menu entries by pressing keys on a telephone. Based on the caller's choice, an auto attendant can offer a submenu, transfer a call to a queue, allow a caller to search an employee directory, send or receive a fax, or perform many other actions. Each menu is owned by a single schedule. Menus become active when the conditions stipulated by the schedule form are met. In other words, a menu is not available to callers unless its parent schedule is active.

Menu Entry

A menu entry is an action that is assigned to menus. The action associated with that menu entry is executed when the caller presses the assigned key.

Menu Transfer

Transfers a call to another menu within the same profile or a different profile. For example, suppose you create a complex set of submenus that you will use in all profiles. Instead of creating the same menu structure repeatedly in every profile, transfer a call to the special menu. This allows a single menu to be shared by all profiles.

Node

A node is an item in the tree that you can select for editing.

Notifier

The Notifier is an CIC module that acts as a communication center for all other modules. It listens for events generated by other modules and notifies other interested modules that the event has occurred.

Operations

Operations are actions that Interaction Attendant can perform when a user makes a menu selection.

Profile

Attendant compares call characteristics to predefined *profiles* for that server. It gives control over the call to the profile that most closely matches the call. Calls come into a server and are filtered by a profile. Profiles filter calls by DNIS, ANI and/or line or line group information. Wildcards can be used in matching. Calls that don't match a user-defined profile are processed by the default profile. Each profile contains a collection of one or more schedules. Profiles can be scheduled to run at certain times. A profile can also be configured to start for a specific ANI, DNIS or Line Name entry so that callers who dial specific numbers hear specific profiles.

Profile Telephone Number

A telephone number that matches DNIS criteria defined in an Attendant profile (either explicitly or using wildcards) that is used for special routing purposes.

Queue

Queues are containers for calls and other types of interactions that can be processed. Each Interaction Client user has a user queue. Each workgroup, such as marketing or support, has a workgroup queue. Stand-alone phones not connected to PCs and fax machines have station queues.

Queue Transfer

Transfers a call directly to a user, workgroup, or station queue.

Receive Fax

Allows a caller to send a FAX to a specific user or workgroup.

Remote Voice Mail

Allows Interaction Client users to retrieve their voice mail remotely.

Schedule

A schedule is a special form associated with each profile that allows you to control when menus contained within the profile become active. A schedule stipulates when a menu can run.

Station Groups

Station groups are groups of phones in break rooms, conference rooms, and other public areas.

Station Queue

A queue where interactions are placed when they are to be processed by a station.

Submenu

Submenus are menus within menus. They allow you to add branches to your auto attendant. For example, you can set up a submenu for each workgroup in your company, allowing callers to perform a variety of actions within each workgroup. Submenus also allow you to re-use the keys that are used in higher menus. For example, pressing 4 in the top level menu might allow callers to enter a Support submenu. In the Support submenu, callers might press 4 to send a fax.

Subroutine Initiator

Allows you to add your own custom functionality to a menu entry. Using the Subroutine Initiator menu entry requires some handler modification.

Template Export

A export option that saves generic configuration data that can be loaded onto any server. The resulting Attendant configuration file contains the general Attendant layout, but without server-specific information, such as workgroup names, user names, or audio files. The resulting file can be loaded onto a server and customized to match the destination server. This option is geared for partners and administrators who manage multiple sites. It does not require servers to be identically configured.

Trunk

A trunk is a communications line that connects two switching systems, such as the equipment in a telephone company's central office, and the PBX in a company.

User Queue

A queue where interactions (such as calls and chat sessions) intended for an individual user are routed.

Voice Mail Transfer

Allows a caller to leave a voice mail for a specific queue.

Change log

Date	Changes
11-November-2011	IC 4.0 SU 1 <ul style="list-style-type: none"> Updated the Modify CustomSubroutineInitiatorRouter.ihd topic to reflect handler changes in Interaction Designer.
06-September-2012	IC 4.0 SU2 <ul style="list-style-type: none"> Added a new feature, Add Inbound IVR Surveys to a Profile, which details how to create an on-demand survey, such as employee satisfaction requests and mandatory health management surveys, in Interaction Feedback and initiate it within an Interaction Attendant profile. Enable IVR Reporting was added to all operations for email configuration profiles. This option determines whether or not reporting data will be collected when control passes through this node. Several IVR Reports summarize this information. IVR Reporting is disabled by default. Enable it to capture the date, time and duration of time that the email remained in the node and its children. This option is hidden when Attendant is connected to a server that does not have reporting installed. For more information about this feature, see IVR Reporting Option. The right to create a new profile is configured in Interaction Administrator, and they can be assigned at the Default User, Role, User, or Workgroups level. Create profile rights are managed on the Security tab in Interaction Administrator. This tab allows the Administrator to grant a user the rights to create inbound, outbound, operator, and email profiles. In Interaction Attendant, if the New Profile button on the toolbar is greyed out, or the New Profile option located in the Insert menu is unavailable, you do not have the appropriate rights to create a new profile. If you have the appropriate rights to create a new profile, Interaction Attendant also automatically grants you the rights to modify that profile. This feature allows you to edit any profile you create. For more information, about appropriate rights to create a new profile, see Custom Inbound Call Profile, Custom Outbound Call Profile, Custom Operator Profile, Email Custom Profile, Rights required to use Attendant, Access Right Examples, or contact your administrator. You can now Configure Selection Nodes and Configure Expression Cases for e-mail interactions as well as calls. Reason and finish codes have been replaced by wrap-up codes and wrap-up categories. See Disposition Interaction Dialer Call.

- When you create a logical expression based upon data about the current call, you can create comparison operators for call routing attributes such as ANI, DNIS, trunk line, or call attributes, and compare against a value entered numerically or as a string. Prior to IC 4.0 SU 3, you could only use a string value. For more information, see [Data about the current call](#).
- The **Queue Update Skills** action adds the ability to modify skill requirements while a call is in-queue. In previous releases, you could only assign skill requirements to an interaction from the Advanced Workgroup Settings dialog within a Workgroup Transfer. To modify those skills, the call had to be moved to another queue, or re-queued within the same workgroup transfer, causing the call to be counted as queueing twice. In IC 4.0 SU 3, add the Queue Update Skills action as an in-queue action under a workgroup transfer. This action is called after a certain amount of time and allows you to add or remove skills without transferring the call to a different queue. For more information, see [Add and Remove Skills from an In-Queue Call](#).
- In conjunction with the [Queue Update Skills](#) action, two new [dynamic call attributes](#) were added to Interaction Attendant:
 - **Eic_AttDynamicSkillstoAdd**. This attribute contains a list of skills that can be added to an in-queue interaction.
 - **Eic_AttDynamicSkillsToRemove**. This attribute contains a list of skills that can be removed from an in-queue interaction.
- Dynamic routing enhancements allow the option to transfer interactions to the voice mailbox of a user or workgroup as specified by interaction attributes. Use the [Set Attribute](#) feature to define characteristics for the desired attribute. For more information, see [Transfer to Voicemail](#).
 - **Eic_AttDynamicUserVmail**. This attribute contains the user selected for voicemail transfer. The voice mailbox of the user defined in this interaction attribute becomes the destination for the voicemail.
 - **Eic_AttDynamicWorkgroupVmail**. This attribute contains the workgroup to use for the voicemail transfer. The voice mailbox of the workgroup defined in this interaction attribute becomes the destination for the voicemail.
- The rights required to use Interaction Attendant are configured outside Interaction Attendant, in Interaction Administrator. The process of assigning these rights changed in Interaction Administrator, and the [Rights required to use Attendant](#) was updated to reflect the new process.
- In the Play Info node, when you define an audio file attribute in the Play Info Sequence Entry dialog, depending on whether you select Text or Date in the Attribute Format Field, you can enter the Date Time attribute in different forms. For more information, see [Play Info](#).
- The [Add additional tools to the Tool list box](#) directs the user to create a text file and name it OtherTools.IAT to add additional tools. However, this file already exists in the Resources folder. The user should add new tools to this existing file rather than creating a new file.
- If you have a media server installed with a configured audio source, you can now direct the Audio Playback form and the Queue Audio form to play audio from an external source; for example, an internet radio station, iPod, or CD player. Interaction Attendant will play audio from a file or audio source to a user in the IVR. These external audio sources must be defined and configured in Interaction Administrator before you can select them in the Play Audio node or the Queue Audio node. For more information, see [Play Audio](#) or [Play a Message to the caller](#).
- If you add a Callback node as part of queue operations, you can configure a prompt to inform the caller that the system successfully processed and scheduled the callback. An Announce Callback Scheduled frame within the Request Callback node provides controls for setting the callback announcement. This frame only appears in an in-queue menu, and gives the caller confirmation that an agent is scheduled to return the call. The caller can disconnect the interaction, rather than continuing to wait for an available agent. For more information, see [Callback Request](#).
- You can now place the Caller Data Entry node within an in-queue menu. When you also add a Request Callback node to the in-queue menu, you can configuring the Caller Data Entry node's Action When Finished frame to jump to the Request Callback node, and set the Request Callback node's Callback Number frame to the appropriate Caller Data Entry node listed in the in-queue menu. This configuration lets the caller enter a specific telephone number during a callback request, and Interaction Attendant will pull that number from the Caller Data Entry node when processing the callback request. For more information, see [Caller Data Entry](#) and [Callback Request](#).

27-November-2013	<p>IC 4.0 SU4</p> <ul style="list-style-type: none"> • Speech Recognition is now available for inbound call profiles, schedules, menus, and operations. You can set up and configure speech recognition to offer callers the ability to navigate the IVR by verbally communicating their choices instead of (or in addition to) using a keypad to enter choices numerically. If you have appropriate rights, you can customize default settings, configured by your administrator, such as minimum confidence levels, timeouts, audio prompts played to the caller if the speech engine cannot determine the caller's selection, manage custom attributes, and record notes about configuration settings and changes. You can also set up custom keywords and phrases a caller might use to verbally indicate the location to which they want to transfer. You enable speech recognition at the profile level, customize settings at the schedule or menu level, and define keywords and phrases at the inbound call operations level. For more information or to get started, see Speech Recognition Overview and Working with Speech Recognition. • Timezone drop-down lists are available in custom inbound call schedules, custom operator schedules, and custom email schedules. Use the Timezone drop-down list to optionally configure a timezone setting. The IC server uses the setting you select to determine actual opening hours for this queue, based on the offset between the IC server and the opening hours/timezone. The timezone setting should be optionally and by default it should use the server time.
04-November-2014	<p>2015R1</p> <ul style="list-style-type: none"> • Updated documentation to reflect changes required in the transition from version 4.0 SU# to CIC 2015 R1, such as updates to product version numbers, system requirements, installation procedures, references to PureConnect Product Information site URLs, and copyright and trademark information. • Added a warning about ACD Server functionality when updating skills in an in-queue interaction. When you update skills in an in-queue call, Interaction Attendant temporarily removes the interaction from the workgroup queue when updating the ACD skills. The interaction is reprocessed when Attendant returns it to the queue, and resets any existing ACD statistics such as Queue Timeout and the interaction's position in queue. For more information about updating skills and ACD behavior, see Add and Remove Skills from an In-Queue Call.
02-May-2017	<p>2017 R3</p> <ul style="list-style-type: none"> • Minor updates to Email-Disconnect topics. • Updated Remotely Activate an Unplanned Schedule topic to require Modify permissions instead of Administrator rights.
31-October-2017	<p>2018 R1</p> <ul style="list-style-type: none"> • Rebranded to apply Genesys terminology. Updated copyright and trademark information.
20-February-2018	<p>2018 R2</p> <ul style="list-style-type: none"> • Update with rebranded terminology and screen captures. • Updated Other Tools topic to indicate that functionality for Parse Name Pair Attributes option has been deprecated.
15-May-2018	<p>2018 R3</p> <ul style="list-style-type: none"> • Added information about average queue length to Data about a particular workgroup (ACD or Custom) topic. • Updated Disposition Interaction Dialer Call topic to add information about the disposition timer associated with the Dialer Call Completed node.
21-August-2018	<p>2018 R4</p> <ul style="list-style-type: none"> • Updated Logical transfer topic to include note about using a Logical Transfer in an Expression Case.
13-November-2019	<p>2018 R5</p> <ul style="list-style-type: none"> • Updated queue repeat description in Repeat a Sequence of queue operations topic. • Updated description of Seconds to wait before switching to Auto-Attendant Processing option in the Call Processing Style Dialog topic.
28-February-2019	<p>2019 R2</p> <ul style="list-style-type: none"> • Updated Schedule Types topic to indicate that if more than one schedule matches in priority, the start times are compared. • Created this change log.

29-April-2019	Updated Caller Data Entry topic to explain timeout behavior if speech recognition is enabled.
23-May-2019	Updated Average Queue Length description in the Data about a particular workgroup (ACD or Custom) topic.
12-June-2019	Queue Audio operation updated in Play a message to a caller topic.
06-August-2019	Added Average Wait Time description in Data About a Particular WorkGroup (ACD or Custom) topic.
17-September-2019	Updated the Send Message From, Reply To Address(es), Add Cc: Address(es) and Add Bcc: Address(es) fields in the Email Build Reply topic to explain can accept a string of the email address or a string of the email address with corresponding display name.
16-October-2019	Updated Audio Source description of settings in the Play a message to a caller topic.
18-November-2019	Removed duplicate words in Email-Set Routing Options topic.
25-March-2020	Updated "Data about a particular workgroup (ACD or Custom) " topic to clarify number of logged on agents.
06-April-2020	Updated "Enable Speech Recognition for a profile" topic to clarify enable speech recognition for company directory.
19-May-2020	Updated "Caller Data Entry" topic to clarify using an in-queue menu to jump to another in-queue menu.
30-June-2020	Removed related topics reference from Manage Voice Prompts because circular reference.
05-August-2020	Updated Unplanned Schedules topic to clarify schedule is not in effect check box.